



(12) **United States Patent**  
**Hinque**

(10) **Patent No.:** **US 9,205,714 B2**  
(45) **Date of Patent:** **\*Dec. 8, 2015**

(54) **COMPACT VALVE SYSTEM FOR SELF-INFLATING TIRE**

(56) **References Cited**

(71) Applicant: **The Goodyear Tire & Rubber Company, Akron, OH (US)**

(72) Inventor: **Daniel Paul Luc Marie Hinque, Habay-le-Neuve (BE)**

(73) Assignee: **The Goodyear Tire & Rubber Company, Akron, OH (US)**

(\* ) Notice: Subject to any disclaimer, the term of this patent is extended or adjusted under 35 U.S.C. 154(b) by 351 days.  
  
This patent is subject to a terminal disclaimer.

U.S. PATENT DOCUMENTS

1,050,886 A *	1/1913	Wetherell .....	152/426
1,250,476 A	12/1917	Hammersmith	
1,413,531 A	4/1922	Harris	
3,304,981 A *	2/1967	Sheppard .....	152/426
4,103,549 A	8/1978	Schmidt	
4,601,254 A	7/1986	Huang et al.	
4,651,792 A *	3/1987	Taylor .....	152/415

(Continued)

FOREIGN PATENT DOCUMENTS

GB 2255850 B 11/1994

OTHER PUBLICATIONS

European Search Report.

Primary Examiner — Kip T Kotter

(74) Attorney, Agent, or Firm — June E. Rickey

(21) Appl. No.: **13/783,668**

(22) Filed: **Mar. 4, 2013**

(65) **Prior Publication Data**

US 2014/0174619 A1 Jun. 26, 2014

**Related U.S. Application Data**

(60) Provisional application No. 61/740,296, filed on Dec. 20, 2012.

(51) **Int. Cl.**  
**B60C 23/12** (2006.01)  
**B60C 29/04** (2006.01)

(52) **U.S. Cl.**  
CPC ..... **B60C 29/04** (2013.01); **B60C 23/12** (2013.01); **Y10T 152/10495** (2015.01)

(58) **Field of Classification Search**  
CPC ..... B60C 23/12; B60C 29/04  
USPC ..... 152/419, 423, 424, 425, 426, 429  
See application file for complete search history.

(57) **ABSTRACT**

A self-inflating tire assembly includes an air passageway in the tire that is operable to be sequentially flattened by the tire footprint in a direction opposite to a tire direction of rotation to pump air from an inlet device through the passageway to an outlet device for direction into the tire cavity. A valve device for a tire is also disclosed. The valve device includes an insert mounted in the tire, a valve body mounted within the valve insert; wherein the valve body has a first, second and third chamber, wherein a first and second check valve is positioned in the first and second chamber. A pressure membrane is received within the valve body, and positioned to open and close the third chamber. The pressure membrane is in fluid communication with the tire cavity and the third chamber of the valve body. A spring is received within the third chamber and is positioned to exert force upon the pressure membrane to bias the pressure membrane position relative to the channel in the open position.

**27 Claims, 12 Drawing Sheets**

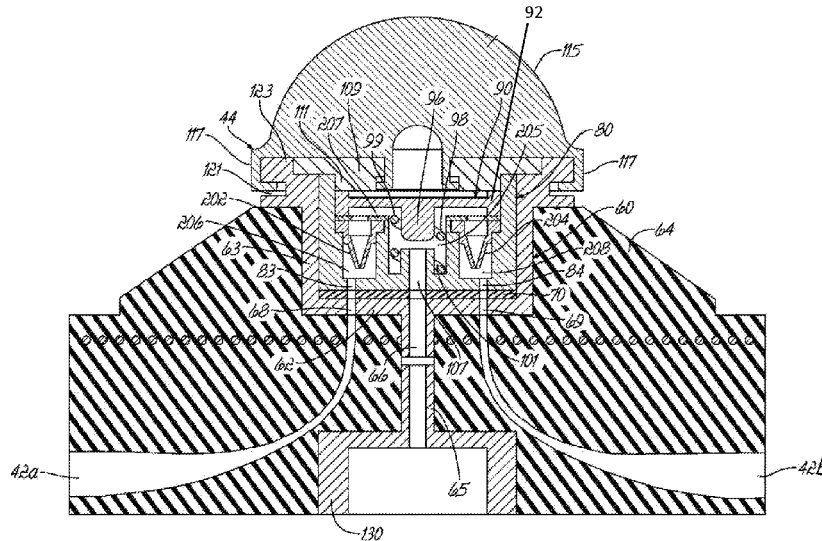

(56)

**References Cited**

U.S. PATENT DOCUMENTS

5,856,619 A 1/1999 Wang  
6,525,655 B2 2/2003 Huang  
6,531,960 B1 3/2003 Gladstone et al.  
6,595,046 B2 7/2003 Lemberger et al.  
6,911,903 B2 6/2005 Gladstone et al.  
7,131,632 B2 11/2006 Kish, Jr.  
7,421,889 B2 9/2008 Lin  
7,493,808 B2 2/2009 Milanovich et al.  
7,667,583 B2 2/2010 Petrucelli

7,764,168 B1 7/2010 Huang  
8,381,785 B2\* 2/2013 Losey ..... 152/450  
8,573,270 B2 11/2013 Hinue  
2005/0072349 A1 4/2005 Perlin et al.  
2010/0243121 A1\* 9/2010 Eigenbrode ..... 152/419  
2011/0146868 A1\* 6/2011 Losey et al. .... 152/426  
2012/0241064 A1\* 9/2012 Hinue et al. .... 152/418  
2013/0048176 A1 2/2013 Hinue  
2013/0048178 A1 2/2013 Hinue  
2014/0000778 A1\* 1/2014 Gobinath ..... 152/450  
2014/0020805 A1\* 1/2014 Gobinath et al. .... 152/450  
2014/0174619 A1 6/2014 Hinue

\* cited by examiner

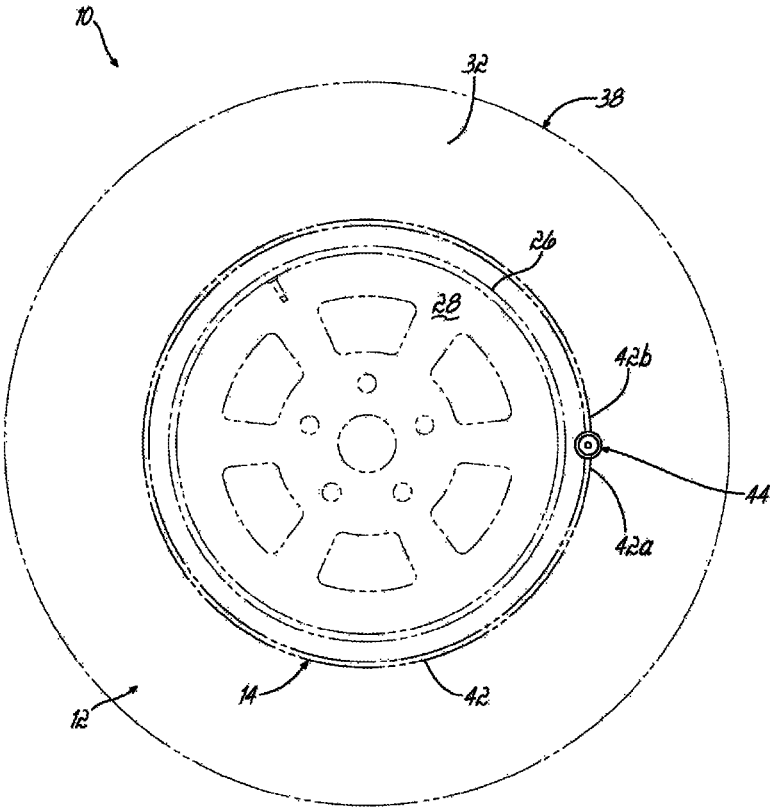

FIG. 1

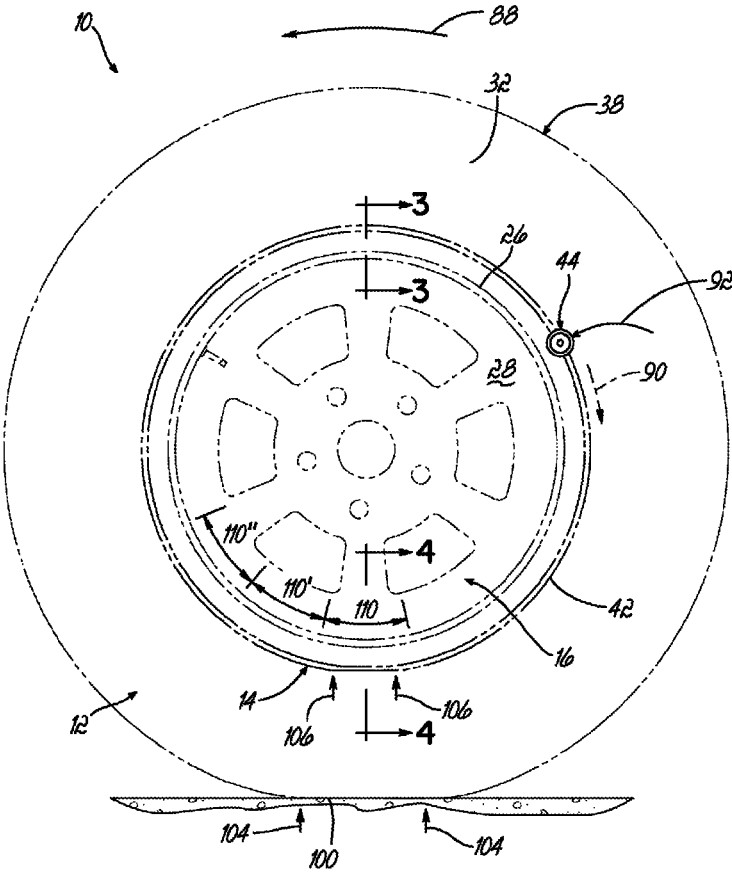

FIG. 2

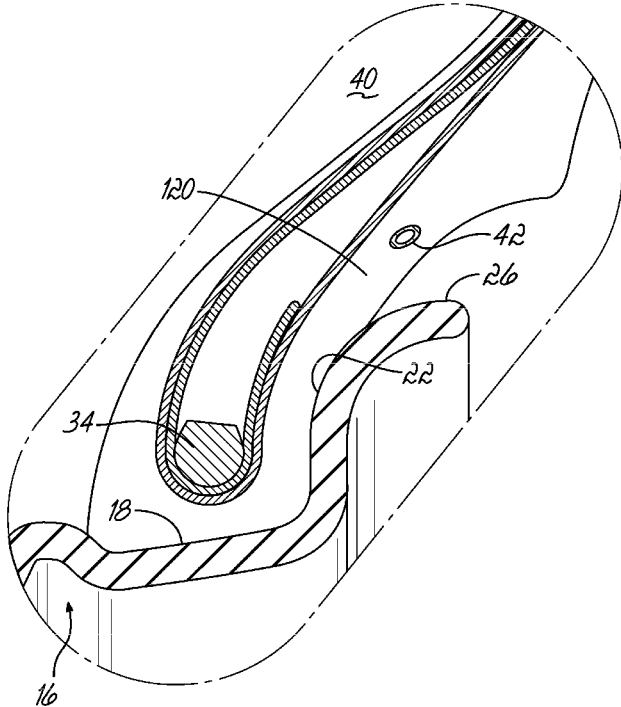

FIG. 3

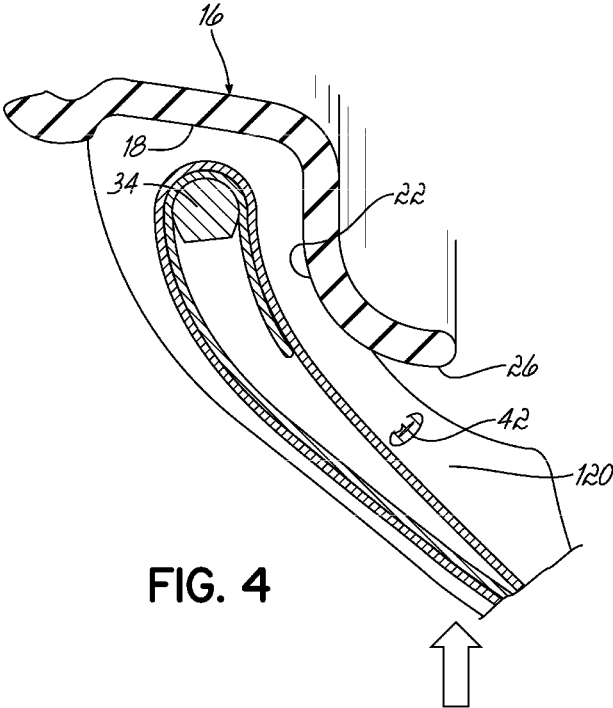
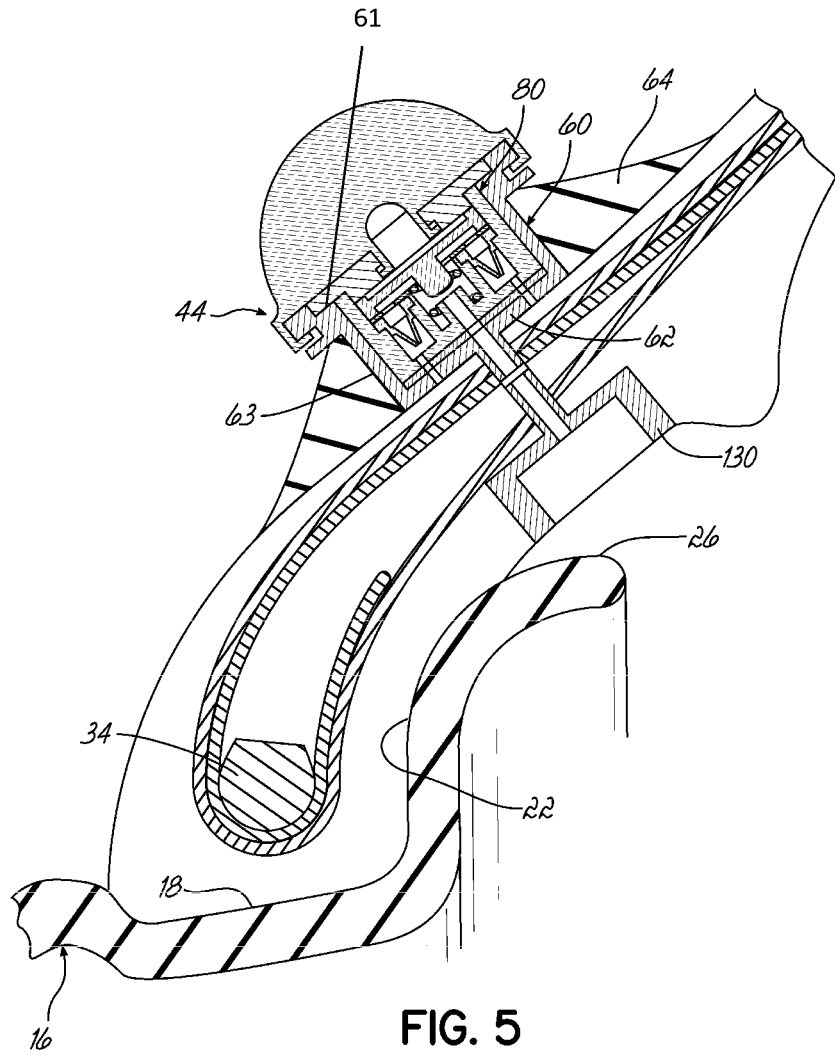

FIG. 4



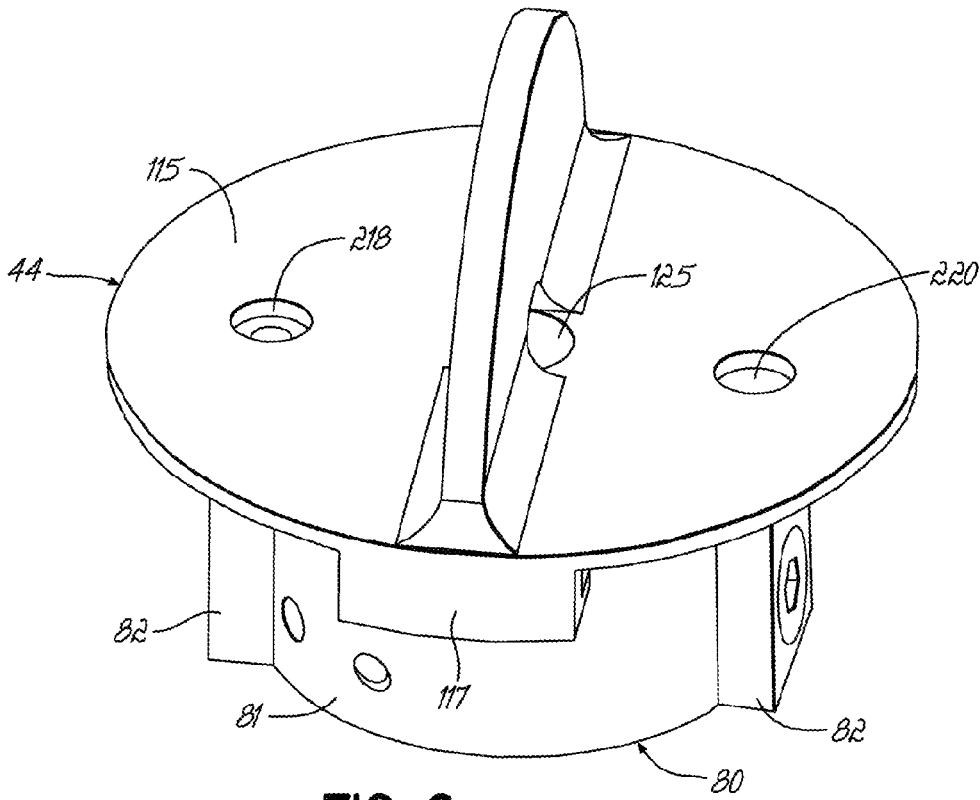

FIG. 6

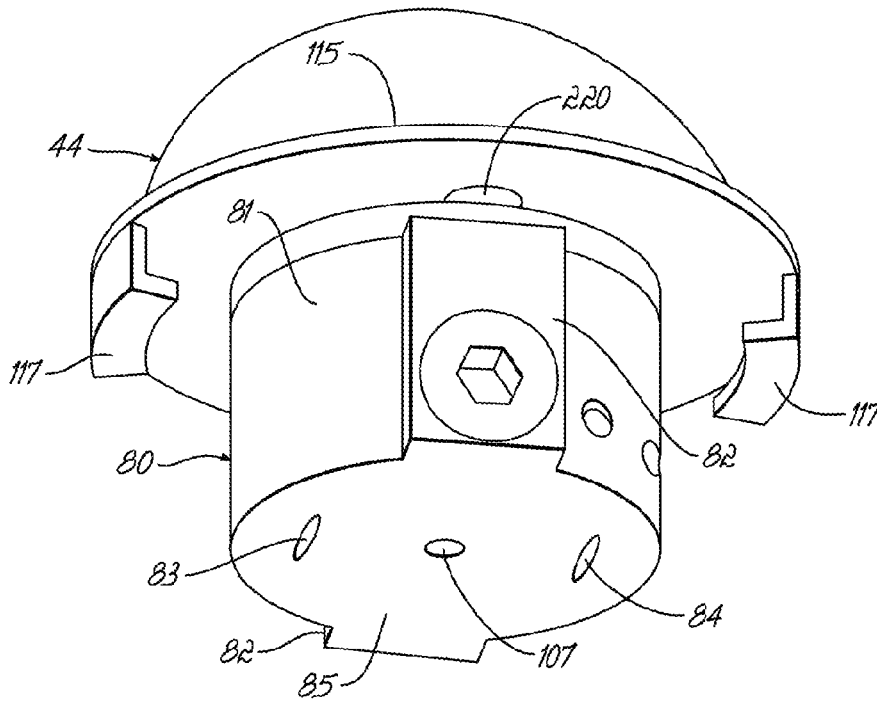

FIG. 7

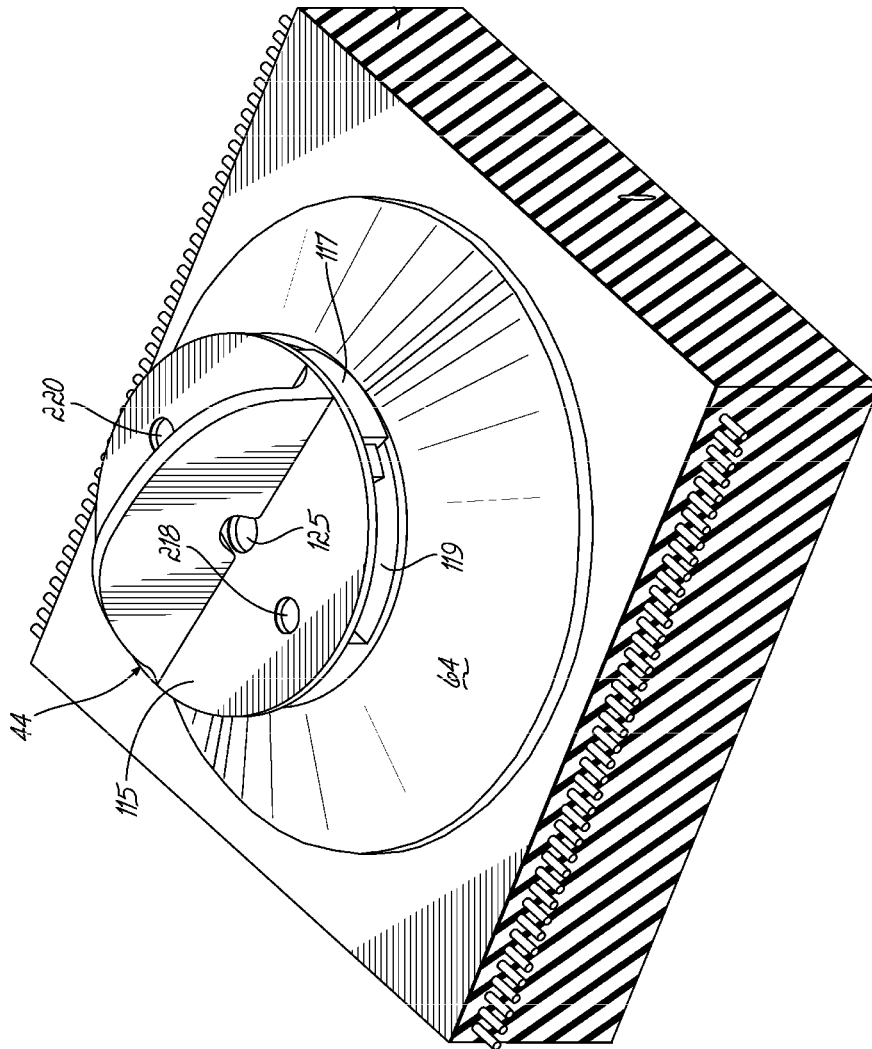

FIG. 8



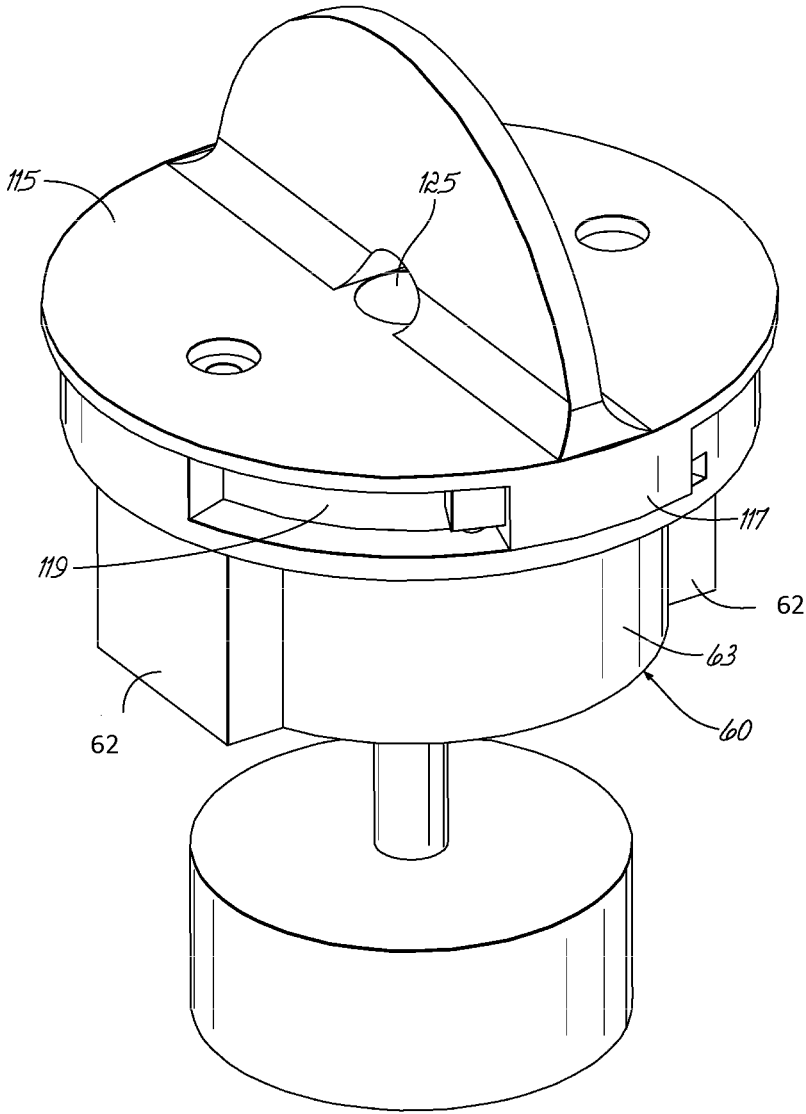

FIG. 9

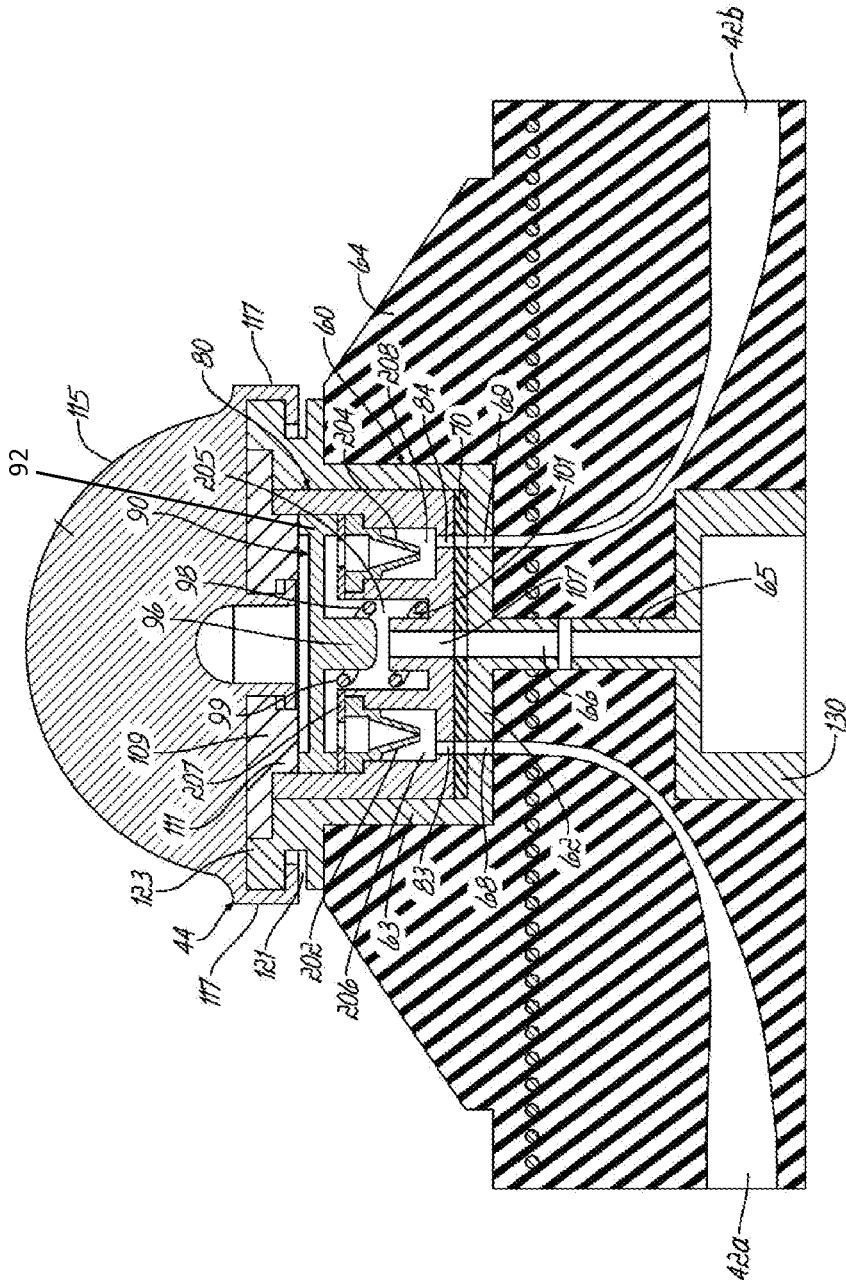

FIG. 10



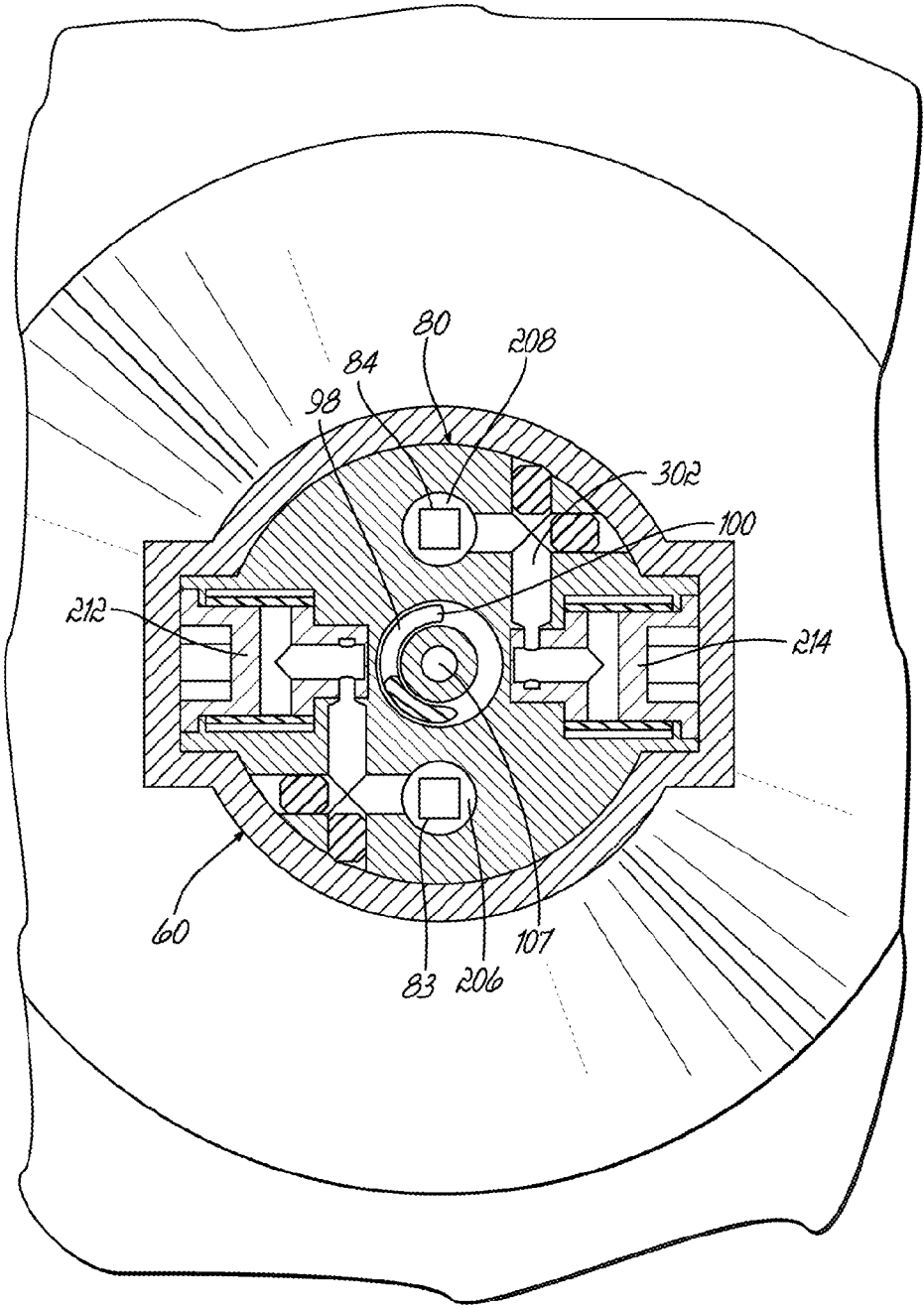

FIG. 12

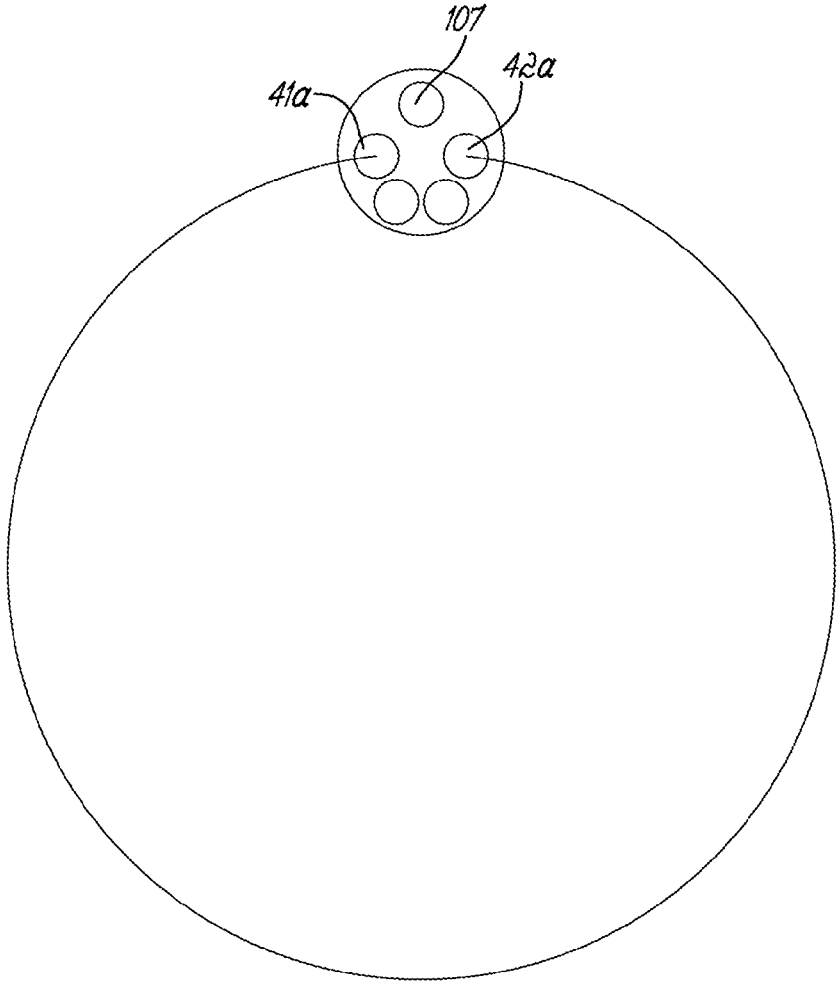

FIG. 13

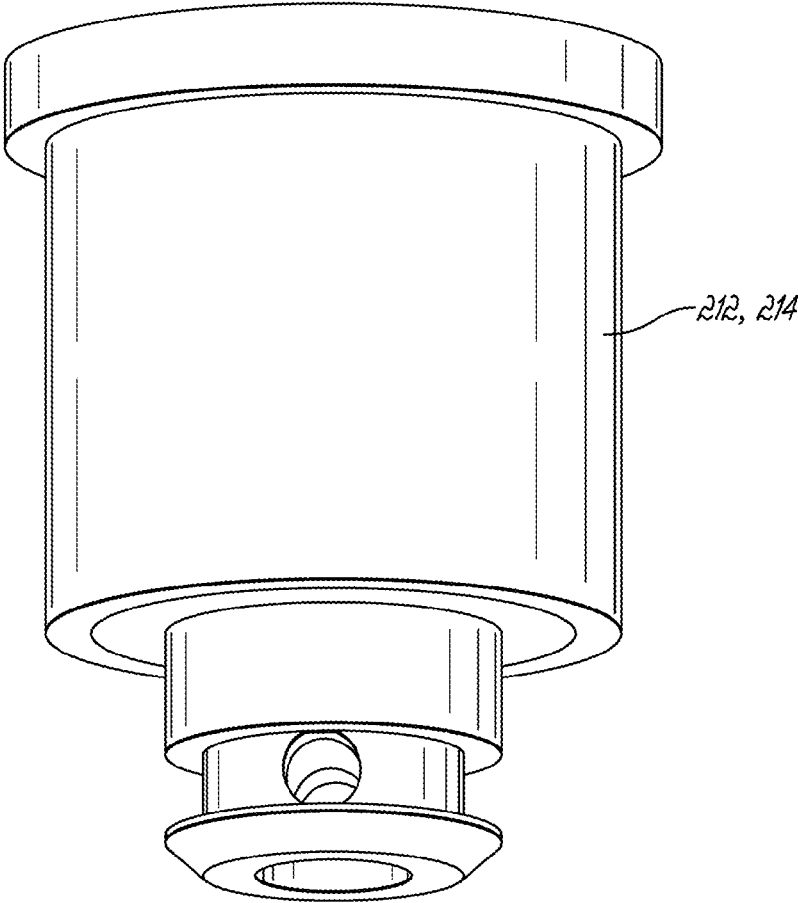

FIG. 14

1

## COMPACT VALVE SYSTEM FOR SELF-INFLATING TIRE

### FIELD OF THE INVENTION

The invention relates generally to self-inflating tires and, more specifically, to a pump mechanism for such tires.

### BACKGROUND OF THE INVENTION

Normal air diffusion reduces tire pressure over time. The natural state of tires is under inflated. Accordingly, drivers must repeatedly act to maintain tire pressures or they will see reduced fuel economy, tire life and reduced vehicle braking and handling performance. Tire Pressure Monitoring Systems have been proposed to warn drivers when tire pressure is significantly low. Such systems, however, remain dependant upon the driver taking remedial action when warned to re-inflate a tire to recommended pressure. It is a desirable, therefore, to incorporate a self-inflating feature within a tire that will self-inflate the tire in order to compensate for any reduction in tire pressure over time without the need for driver intervention.

### SUMMARY OF THE INVENTION

The invention provides in a first aspect a self-inflating tire assembly comprising a tire having a tire cavity, a first and second sidewall extending respectively from first and second tire bead regions to a tire tread region; The tire has an air passageway that has an inlet end and an outlet end and is operative to allow a portion of the air passageway near a tire footprint to substantially close the passageway. The assembly includes a valve device connected to the inlet end and outlet end of the air passageway, wherein the valve device has a valve body having a first, second and third chamber, the first chamber having a first hole in fluid communication with the inlet end of the first air passageway, the second chamber having a second hole in fluid communication with the outlet end of the air passageway and a third chamber having a channel in fluid communication with the ambient air; wherein a first and second check valve is positioned in the first and second chamber; wherein a pressure membrane is received within the valve body, and positioned to open and close the channel; wherein the second chamber is in fluid communication with the tire cavity.

The invention provides in a second aspect a valve device for a tire, the valve device comprising: an insert mounted in the tire, a valve body mounted within the valve insert; wherein the valve body has a first, second and third chamber, wherein a first and second check valve is positioned in the first and second chamber; wherein a pressure membrane is received within the valve body, and positioned to open and close the third chamber; the pressure membrane is in fluid communication with the tire cavity and the third chamber of the valve body; wherein a spring is received within the third chamber and is positioned to exert force upon the pressure membrane to bias the pressure membrane position relative to the channel in the open position.

### DEFINITIONS

“Aspect ratio” of the tire means the ratio of its section height (SH) to its section width (SW) multiplied by 100 percent for expression as a percentage.

2

“Asymmetric tread” means a tread that has a tread pattern not symmetrical about the center plane or equatorial plane EP of the tire.

“Axial” and “axially” means lines or directions that are parallel to the axis of rotation of the tire.

“Chafer” is a narrow strip of material placed around the outside of a tire bead to protect the cord plies from wearing and cutting against the rim and distribute the flexing above the rim.

“Circumferential” means lines or directions extending along the perimeter of the surface of the annular tread perpendicular to the axial direction.

“Equatorial Centerplane (CP)” means the plane perpendicular to the tire’s axis of rotation and passing through the center of the tread.

“Footprint” means the contact patch or area of contact of the tire tread with a flat surface at zero speed and under normal load and pressure.

“Inboard side” means the side of the tire nearest the vehicle when the tire is mounted on a wheel and the wheel is mounted on the vehicle.

“Lateral” means an axial direction.

“Lateral edges” means a line tangent to the axially outermost tread contact patch or footprint as measured under normal load and tire inflation, the lines being parallel to the equatorial centerplane.

“Net contact area” means the total area of ground contacting tread elements between the lateral edges around the entire circumference of the tread divided by the gross area of the entire tread between the lateral edges.

“Non-directional tread” means a tread that has no preferred direction of forward travel and is not required to be positioned on a vehicle in a specific wheel position or positions to ensure that the tread pattern is aligned with the preferred direction of travel. Conversely, a directional tread pattern has a preferred direction of travel requiring specific wheel positioning.

“Outboard side” means the side of the tire farthest away from the vehicle when the tire is mounted on a wheel and the wheel is mounted on the vehicle.

“Passageway” means an integrally formed pathway in the tire or a discrete tube inserted in the tire forming the pump.

“Peristaltic” means operating by means of wave-like contractions that propel contained matter, such as air, along pathways.

“Radial” and “radially” means directions radially toward or away from the axis of rotation of the tire.

“Rib” means a circumferentially extending strip of rubber on the tread which is defined by at least one circumferential groove and either a second such groove or a lateral edge, the strip being laterally undivided by full-depth grooves.

“Sipe” means small slots molded into the tread elements of the tire that subdivide the tread surface and improve traction, sipes are generally narrow in width and close in the tires footprint as opposed to grooves that remain open in the tire’s footprint.

“Tread element” or “traction element” means a rib or a block element defined by having shape adjacent grooves.

“Tread Arc Width” means the arc length of the tread as measured between the lateral edges of the tread.

### BRIEF DESCRIPTION OF THE DRAWINGS

The invention will be described by way of example and with reference to the accompanying drawings in which:

FIG. 1 is an isometric view of tire and rim assembly showing an annular peristaltic pump assembly.

3

FIG. 2 illustrates a side view of the tire, rim, pump, and valves showing operation of the pump to the tire cavity when the tire rotates.

FIG. 3 is an enlarged cross-sectional view of a pump in the bead area of the tire.

FIG. 4 is an enlarged cross-sectional view illustrating the pump being compressed in the tire bead area.

FIG. 5 is an enlarged cross sectional view of the bead area with a flow controller and filter assembly of the present invention shown mounted in the tire.

FIG. 6 is a side view of the flow controller valve body of the present invention.

FIG. 7 is a bottom view of the flow controller valve body of FIG. 6.

FIG. 8 is a top view of the flow control valve shown mounted in a partial section of the tire.

FIG. 9 is a side perspective view of the flow controller body of FIG. 6 shown mounted in an insert and together with a filter assembly;

FIG. 10 is a cross-sectional side view of the flow controller valve, insert and filter assembly of FIG. 9 shown mounted in a tire sidewall;

FIG. 11 is a cross-sectional side view of the flow control valve, insert and filter assembly of FIG. 9 shown mounted in a tire sidewall at a 90 degree angle with respect to FIG. 10;

FIG. 12 is a cross-sectional view of the flow control valve of FIG. 11, in a direction 12-12 of FIG. 11;

FIG. 13 is a schematic illustrating the pump connection.

FIG. 14 is a side perspective view of a check valve.

#### DETAILED DESCRIPTION OF THE INVENTION

Referring to FIGS. 1 and 3, a tire assembly 10 includes a tire 12, a peristaltic pump assembly 14, and a tire rim 16. The tire mounts in a conventional fashion to a pair of rim mounting surfaces 18 located adjacent outer rim flanges 22. The outer rim flange 22 has an outer rim surface 26. An annular rim body 28 joins the rim flanges 22 and supports the tire assembly as shown. The tire is of conventional construction, having a pair of sidewalls 32 extending from opposite bead areas 34 to a crown or tire tread region 38. The tire and rim enclose an interior tire cavity 40.

As shown in FIG. 1 the peristaltic pump assembly 14 includes a pump passageway 42 that is mounted or located in the sidewall area of the tire, preferably near the bead region. The pump passageway 42 may be formed of a discrete tube made of a resilient, flexible material such as plastic, elastomer or rubber compounds, and is capable of withstanding repeated deformation cycles when the tube is deformed into a flattened condition subject to external force and, upon removal of such force, returns to an original condition generally circular in cross-section. The tube is of a diameter sufficient to operatively pass a volume of air sufficient for the purposes described herein and allowing a positioning of the tube in an operable location within the tire assembly as will be described. Preferably, the tube has a circular cross-sectional shape, although other shapes such as elliptical may be utilized.

The pump passageway may also be integrally formed into the sidewall of the tire during vulcanization, eliminating the need for an inserted tube. An integrally formed pump passageway is preferably made by building into a selected green tire component such as a chafer, a removable strip made of wire or silicone. The component is built into the tire and cured. The strip is then removed post cure to form a molded in or integrally formed pump air passageway.

4

Hereinafter, the term "passageway" refers either to installed tubes or integrally molded passageway. FIGS. 1 and 2 are illustrations of the pump in the tire, and are not shown in phantom as they should be, in order to facilitate understanding of the system. The location selected for the air passageway within the tire may be within a tire component residing within a high flex region of the tire, sufficient to progressively collapse the peristaltic internal hollow air passageway as the tire rotates under load thereby conveying air along the air passageway from the inlet to the pump outlet.

The pump air passageway 42 has an inlet end 42a and an outlet end 42b joined together by a flow controller 44. As shown, the inlet end 42a and the outlet end 42b are spaced apart approximately 360 degrees forming an annular pump assembly.

A first embodiment of a flow controller 44 is shown in FIGS. 5-13. The flow controller 44 device functions to regulate the inlet flow and exit flow of the pump 42. As shown in FIG. 10, the flow controller 44 includes an outer insert 60 that is inserted into a receptacle 64 built in the tire.

The receptacle 64 is a raised hump formed on the tire inner surface and may optionally include a threaded inner hole, wherein the hump is built into the tire sidewall using a series of concentric layers of material, such as uncured elastomer, green rubber. A one piece molded shape may also be used instead of the concentric layers.

Alternatively, the outer insert 60 may be inserted into the receptacle prior to vulcanization. The outer insert may be made of green rubber, elastomer, nylon, ultra high molecular weight polyethylene or metal such as brass. The insert is preferably coated with a suitable adhesive such as resorcinol formaldehyde latex (RFL) or commonly referred to as "dip" known to those skilled in the art. The outer surface of the insert may be roughened and coated with the selected RFL. The outer surface of the insert may further include ridges, flanges, extensions, threads or other mechanical means in addition to the selected RFL to retain the insert into the rubber of the tire sidewall. Alternatively, the insert and/or the valve device may be cured in the tire sidewall.

The optional outer insert 60 has an interior section formed by an open end 61 facing the tire cavity, a bottom wall 62 opposite the open end and a sidewall 63. The bottom wall has a male portion 65 extending from the bottom wall. The male portion has a hole 66 there through for communicating filtered air to the interior of the valve. The bottom portion also has two opposed holes 68, 69 for alignment and fluid communication with the pump passageways 42a, 42b. A gasket 70 is positioned on the bottom wall 62 of the insert 60. The gasket is circular and flat, with three holes aligned with the three holes 66, 68, 69 of the insert 60. The gasket may also have protruding rims around the three holes.

The flow controller device further comprises a valve insert 80 as shown in FIGS. 6, 7, 10 and 11. The outer body 81 of the valve insert is generally cylindrically shaped, with one or more alignment keys 82 projecting from the body. The one or more alignment keys are seated in mating engagement with an alignment slot 63a formed in the sidewall 63 of the outer insert 60. The alignment keys 82 ensure that holes 83, 84 on the bottom surface 85 of the valve body aligns with holes 68, 69 of the insert. The insert 60 is an optional component that may be eliminated, and the outer surface of the valve insert 80 may be threaded for reception into the receptacle 64.

A pressure membrane 90 is received within the valve body inner chamber 205 wherein the outer flanged rim 92 of the pressure membrane 90 is seated on a flow control plate 207. The pressure membrane 90 is preferably disk shaped and formed of a flexible material such as, but not limited to,



5

rubber, elastomer, plastic or silicone. On the side of the pressure membrane facing a central chamber, a plug 96 protrudes from the membrane. The plug is positioned to plug a channel 107 protruding from the bottom wall of the chamber and prevent flow from the outside air into the chamber 205, and hence, airflow into the pump passageway 42.

A spring 98 has a first end 99 wrapped around the plug 96, and a second end 101 wrapped around the channel 107 which extends from the bottom wall of the third chamber. The tire cavity pressure overrides the opposing spring force and biases the pressure membrane into the closed position until the tire cavity pressure falls below a threshold value. The channel 107 extends from the chamber 205 through the bottom surface and in alignment with the hole 66 of male portion 65 of the insert 60. Channels 107 and 66 are in fluid communication with a filter assembly 130. The filter assembly 130 is mounted on the outside portion of the tire, opposite the flow controller. The filter assembly has filter media (not shown) for filtering the outside air and preventing debris and fluid from entering the pump. The filter assembly may be formed of a hard plastic cup shaped device mounted in the tire sidewall preure or post-ure, and have an opening in fluid communication with the internal chamber 205 of the valve body.

As shown in FIGS. 9 and 11, lid 109 is positioned over the pressure membrane 90. The lid has a flanged portion 111 which engages the rim of the pressure membrane. The lid 109 further includes a central hole 113. The lid 109 is secured to the flow controller 44 via a slideable retainer 115. The retainer 115 has opposed U shaped ends 117 which are first aligned into opposed cutout recesses 119, and then rotated into engagement with mating grooves 121 of flanged ends 123 of insert 60. The retainer 115 has a central hole 125 to allow fluid communication with the central hole 113 of cap 109, so that the pressure membrane is responsive to the pressure in the tire cavity.

The valve insert 80 has three interior chambers 205, 206, 208. A first duckbill or check valve 202 is positioned in the first chamber 206 to prevent air from pump tube back flowing into flow controller. The first chamber 206 is in fluid communication with an outlet passageway 218. The outlet passageway 218 is in fluid communication with the tire cavity 40. A check valve 214 is positioned in the outlet passageway to prevent cavity air from flowing into the flow controller.

A second duckbill or check valve 204 is positioned in second chamber 208. The second chamber 208 is also in fluid communication with a second outlet passageway 220. The second outlet passageway 220 is in fluid communication with the tire cavity 40. A second check valve 212 is positioned in the second outlet passageway 220 to prevent backflow of cavity air into the flow controller. The arrangement of the valves in the first and second chamber allow the tire to be a bidirectional pump.

The third chamber 205 has a channel 107 which supplies filtered outside air to the flow controller. The plug of the pressure membrane is positioned in the third channel to close off flow from the channel 107. A spring 98 is housed within third chamber 205, and is positioned to bias the pressure membrane in the open position when the tire cavity pressure falls to the Pset level, wherein Pset is the tire pressure value at which the control valve opens and allows air into the pump to initiate pumping action.

The third channel has an open hole 201 (opposite channel 107) through a flow control plate 207. The flow control plate 207 has aligned holes 209, 211 to direct the flow into the duckbill valves 202, 204 from the third chamber 205. The duckbill valves 202/204 prevent backflow from the pump passageway into the chambers 206,208.

6

The pressure membrane 90 is responsive to the pressure in the interior of the tire cavity 40 on one side of the membrane, and is responsive to the pressure in the inlet chamber on the other side of the membrane. If the tire pressure is sufficiently high, the tire pressure pushes the plug of the membrane into sealing engagement with the channel 107, overcoming the spring force, wherein the pressure membrane seals off flow from the channel 107 so that no airflow may enter the pump inlet end 42a. As the tire loses air pressure it will reach a set trigger pressure Pset. When the tire pressure is at or below the trigger pressure Pset, the spring force is sufficient to unseat the pressure membrane plug from the channel, opening up the channel 107. Filtered, outside air may then enter the flow controller through the channel 107 of the valve body, then through the third or central chamber 205, and out hole 83 into pump inlet 42a. As the tire rotates, the air is pumped from the pump inlet 42a to the pump outlet 42b. As the flow enters chamber 208, the fluid enters the outlet one way or check valve 214 through passageway 302. FIG. 12 illustrates the valve body with a portion of the valve body wall removed to illustrate that check valve 214 is in fluid communication with chamber 208 via passageway 302. Flow exits check valve 214 into outlet channel 220, into tire cavity. Alternatively, if the tire is rotated in the opposite direction, the flow would reverse and perform as described above, except that the flow would exit through check valve 212 and through outlet passageway 218.

As will be appreciated from FIG. 2, air maintenance pump 42 is a 360 degree pump, with the inlet and outlet co-located. If the tire cavity pressure is below the trigger pressure, membrane plug opens the channel 107 allowing filtered outside air to enter the valve body chamber 205 and into the pump tube inlet 42a. As the tire rotates in a direction of rotation 88, a footprint 100 is formed against the ground surface. A compressive force 104 is directed into the tire from the footprint 100 and acts to flatten a segment 110 of the pump 42 a as shown at numeral 106. Flattening of the segment 110 of the pump 42 forces a portion of air located between the flattened segment 110 and the flow controller 44, towards the flow controller 44. As the tire continues to rotate in direction 88 along the ground surface 98, the pump tube 42 will be sequentially flattened or squeezed segment by segment 110, 110', 110" in a direction 90 which is opposite to the direction of tire rotation 88. The sequential flattening of the pump tube 42 segment by segment causes the column of air located between the flattened segments to be pumped to the pump outlet 42b. Flow enters the flow controller chamber 208 and then into the inlet port of check valve 202 and then exits outlet channel 220 into the tire cavity. With the tire rotating in direction 88, flattened tube segments are sequentially refilled by air 92 flowing into the flow controller 44 along the pump tube 42 in the direction 90 as shown by FIG. 2. This cycle continues until the tire cavity pressure is sufficient to overcome the spring force 98 and plug the channel, no longer allowing air flow to enter the pump.

The location of the peristaltic pump assembly will be understood from FIGS. 3-4. In one embodiment, the peristaltic pump assembly 14 is positioned in the tire sidewall, radially outward of the rim flange surface 26 in the chafer 120. So positioned, the air tube 42 is radially inward from the tire footprint 100 and is thus positioned to be flattened by forces directed from the tire footprint as described above. The segment that is opposite the footprint 100 will flatten from the compressive force 106 from the footprint 100 pressing the tube segment against the rim flange surface 26. Although the positioning of the tube 42 is specifically shown as between a chafer 120 of the tire at the bead region 34 and the rim surface

26, it is not limited to same, and may be located at any region of the tire such as anywhere in the sidewall or tread.

From the forgoing, it will be appreciated that the subject invention may be used with a secondary tire pressure monitoring system (TPMS) (not shown) of conventional configuration that serves as a system fault detector. The TPMS may be used to detect any fault in the self-inflation system of the tire assembly and alert the user of such a condition.

Variations in the present invention are possible in light of the description of it provided herein. While certain representative embodiments and details have been shown for the purpose of illustrating the subject invention, it will be apparent to those skilled in this art that various changes and modifications can be made therein without departing from the scope of the subject invention. It is, therefore, to be understood that changes can be made in the particular embodiments described which will be within the full intended scope of the invention as defined by the following appended claims.

What is claimed is:

1. A self-inflating tire assembly comprising:
  - a. a tire having a tire cavity, a first and second sidewall extending respectively from first and second tire bead regions to a tire tread region;
  - b. said tire having a pump passageway, said pump passageway having an inlet end and an outlet end and being operative to allow a portion of the pump passageway the second chamber to substantially close the pump passageway,
  - c. a valve device connected to the inlet end and outlet end of the pump passageway, wherein the valve device has a valve body having a first, second and third chamber, said first chamber having a first hole in fluid communication with the inlet end of the first pump passageway, said second chamber having a second hole in fluid communication with the outlet end of the pump passageway and a third chamber having a channel in fluid communication with the ambient air;
  - d. wherein a first outlet passageway is in fluid communication with the tire cavity and the first chamber, and a second outlet passageway is in fluid communication with a second chamber, wherein a first check valve is positioned in the first outlet passageway to prevent flow from the cavity into the valve device; wherein a second check valve is positioned in the second outlet passageway to prevent flow from the cavity into the valve device; wherein a pressure membrane is received within the valve body, and positioned to open and close the channel.
2. The self-inflating tire assembly of claim 1 wherein the first and second chamber each have a duckbill valve to prevent flow from the pump passageway into the valve body.
3. The self-inflating tire assembly of claim 2 wherein a valve body is mounted within a valve insert.
4. The self-inflating tire assembly of claim 1 wherein the valve device including an insert molded in the tire.
5. The self-inflating tire assembly of claim 1 wherein the pressure membrane is in fluid communication with the tire cavity and the third chamber of the valve body.
6. The self-inflating tire assembly of claim 1 wherein a spring is received within the third chamber and is positioned to exert force upon the pressure membrane to bias the pressure membrane position relative to the channel in the open position.
7. The self-inflating tire assembly of claim 1 wherein the pressure membrane has a plug and a spring has a first end mounted about the plug, wherein the plug is positioned to close the end of the channel.

8. The self-inflating tire assembly of claim 1 wherein a control plate is positioned between the pressure membrane and the first and second check valve, wherein the control plate has a hole aligned for communicating flow from the third chamber into one of the first and second chamber.

9. The self-inflating tire assembly of claim 1 wherein a control plate is positioned between the pressure membrane and the first and second check valve, wherein the control plate has a hole aligned for communicating flow from the third chamber into the first and second chamber.

10. A valve device for a tire, said tire having a tire cavity, the valve device comprising:

- a. a valve body having a first, second and third chamber, wherein a first and second check valve is positioned in the first and second chamber, respectively; wherein the first chamber has a first outlet passageway in fluid communication with the tire cavity and the second chamber has a second outlet passageway in fluid communication with the tire cavity, wherein the first check valve is positioned in the first outlet passageway to prevent flow from the cavity into the valve device; wherein the second check valve is positioned in the second outlet passageway to prevent flow from the cavity into the valve device;
- b. wherein a pressure membrane is received within the valve body, and positioned to open and close the third chamber;
- c. said pressure membrane is in fluid communication with the tire cavity and the third chamber of the valve body;
- d. wherein a spring is received within the third chamber and is positioned to exert force upon the pressure membrane to bias the pressure membrane position relative to a channel of the third chamber into an open position.

11. The valve device of claim 10 wherein the pressure membrane has a plug and the spring has a first end mounted about the plug, wherein the plug is positioned to close an end of the channel.

12. The valve device of claim 10 wherein a control plate is positioned between the pressure membrane and the first and second check valve, wherein the control plate has a hole aligned for communicating flow from the third chamber into the first chamber.

13. The valve device of claim 12 wherein the control plate has a hole aligned for communicating flow from the third chamber into the second chamber.

14. The valve device of claim 10 wherein the check valve is a duck bill type.

15. The valve device of claim 10 wherein an insert is cured in the tire sidewall.

16. A self-inflating tire assembly comprising:

- a. a tire having a tire cavity and a pump passageway, said pump passageway having an inlet end and an outlet end,
- b. a valve device connected to the inlet end and outlet end of the pump passageway, wherein the valve device has a valve body having a first, second and third chamber, said first chamber being in fluid communication with the inlet end of the pump passageway, said second chamber being in fluid communication with the outlet end of the pump passageway, and a third chamber having a channel in fluid communication with the ambient air;
- c. wherein a pressure membrane is received within the valve body, and positioned to open and close the channel.

17. The self-inflating tire assembly of claim 16 wherein the first chamber has a check valve to prevent flow from the pump passageway into the third chamber.

18. The self-inflating tire assembly of claim 16 wherein the second chamber has a check valve to prevent flow from the pump passageway into the third chamber.

19. The self-inflating tire assembly of claim 16 wherein the valve device further includes an insert molded in the tire. 5

20. The self-inflating tire assembly of claim 16 wherein the valve body is mounted within a valve insert.

21. The self-inflating tire assembly of claim 16 wherein the pressure membrane is in fluid communication with the tire cavity and the third chamber of the valve body. 10

22. The self-inflating tire assembly of claim 16 wherein a spring is received within the third chamber and is positioned to exert force upon the pressure membrane to bias the pressure membrane position relative to the channel into an open position. 15

23. The self-inflating tire assembly of claim 16 wherein the pressure membrane has a plug and a spring having a first end mounted about the plug, wherein the plug is positioned to close an end of the channel.

24. The self-inflating tire assembly of claim 16 wherein a first outlet passageway is in fluid communication with the tire cavity and the first chamber. 20

25. The self-inflating tire assembly of claim 24 wherein a first check valve is positioned in the first outlet passageway to prevent flow from the cavity into the valve device. 25

26. The self-inflating tire assembly of claim 16 wherein a second outlet passageway is in fluid communication with a second chamber.

27. The self-inflating tire assembly of claim 26 wherein a second check valve is positioned in the second outlet passage- 30 way to prevent flow from the cavity into the valve device.

\* \* \* \* \*