

(12) **United States Patent**
Hinque et al.

(10) **Patent No.:** **US 8,915,277 B2**
(45) **Date of Patent:** ***Dec. 23, 2014**

(54) AIR MAINTENANCE TIRE AND CONNECTOR SYSTEM	3,304,981 A 2/1967 Sheppard 152/426 3,833,041 A 9/1974 Glad et al. 152/347 4,922,984 A 5/1990 Dosjoub et al. 152/415 5,052,456 A 10/1991 Dosjoub 152/415 7,117,731 B2 10/2006 Hrabal 73/146 7,225,845 B2 6/2007 Ellmann 152/426 8,042,586 B2* 10/2011 Losey et al. 152/426 8,113,254 B2* 2/2012 Benedict 152/426 8,381,785 B2* 2/2013 Losey 152/450 2002/0294006 12/2009 Hrabal 152/426 2010/0243121 A1 9/2010 Eigenbrode 152/419 2013/0112328 A1* 5/2013 Hinque et al. 152/450 2013/0112329 A1* 5/2013 Hinque et al. 152/450
(75) Inventors: Daniel Paul Luc Marie Hinque , Habay-la-Neuve (BE); Gauthier Piret , Ster-Francorchamps (BE); Gilles Bonnet , Niederfenlen (LU); Olivier Di Prizio , Hettange-Grande (FR)	
(73) Assignee: The Goodyear Tire & Rubber Company , Akron, OH (US)	

(*) Notice: Subject to any disclaimer, the term of this patent is extended or adjusted under 35 U.S.C. 154(b) by 433 days.
This patent is subject to a terminal disclaimer.

FOREIGN PATENT DOCUMENTS

CN	1111575	11/1995	B60C 23/10
DE	3433318	9/1984	B60C 23/00
DE	3711785	10/1988	B60C 5/20
DE	3881591	9/1993	B60C 23/00
DE	4323835	1/1995	B60C 23/00
DE	102007018437	12/2007	B60C 23/16
EP	1648721	11/2006	B60C 23/00
WO	2007/134556	11/2007	B60C 23/00
WO	2010/008338	1/2010	B60C 23/12

* cited by examiner

Primary Examiner — Justin Fischer

(74) *Attorney, Agent, or Firm* — Richard B. O'Planick

(21) Appl. No.: **13/332,898**

(22) Filed: **Dec. 21, 2011**

(65) **Prior Publication Data**

US 2013/0160916 A1 Jun. 27, 2013

(51) **Int. Cl.**
B60C 23/00 (2006.01)
B60C 23/10 (2006.01)
B60C 19/00 (2006.01)

(52) **U.S. Cl.**
USPC **152/450; 152/415**

(58) **Field of Classification Search**
None
See application file for complete search history.

(56) **References Cited**

U.S. PATENT DOCUMENTS

1,050,886 A	1/1913	Wetherell
1,134,361 A	4/1915	Wetherell

(57) **ABSTRACT**

An air maintenance tire and connector system includes a tire carcass having an elongate integral air passageway contained within a flexible tire component of the tire carcass between an air inlet and an air outlet cavity and a connector assembly inserted within one or both of the cavities. A coupling post having an axial bore extends from the hollow body through a tire wall thickness to a tire central cavity. A remote end of the coupling post is operative for sequential alternative attachment to a punch device for penetrating in a pre-cure procedure through the tire wall thickness to the tire central cavity.

14 Claims, 73 Drawing Sheets

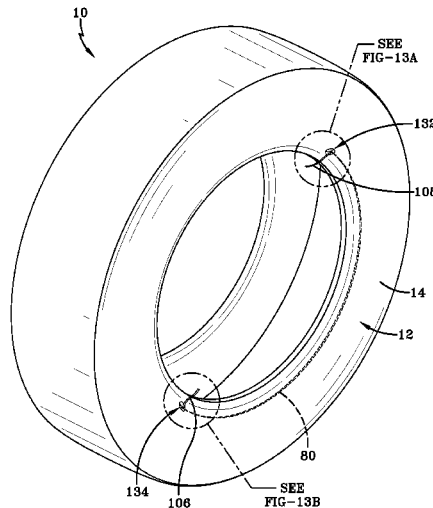

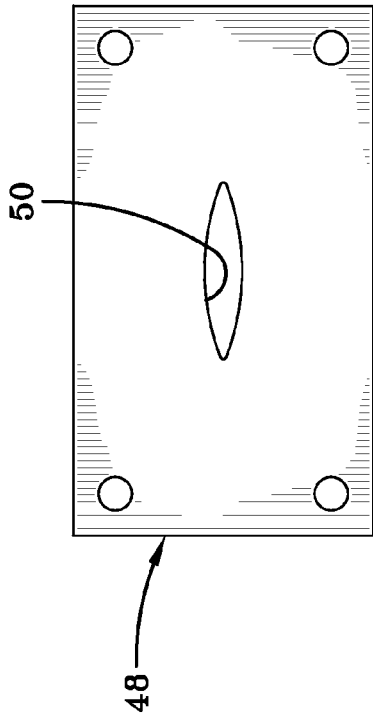

FIG-1

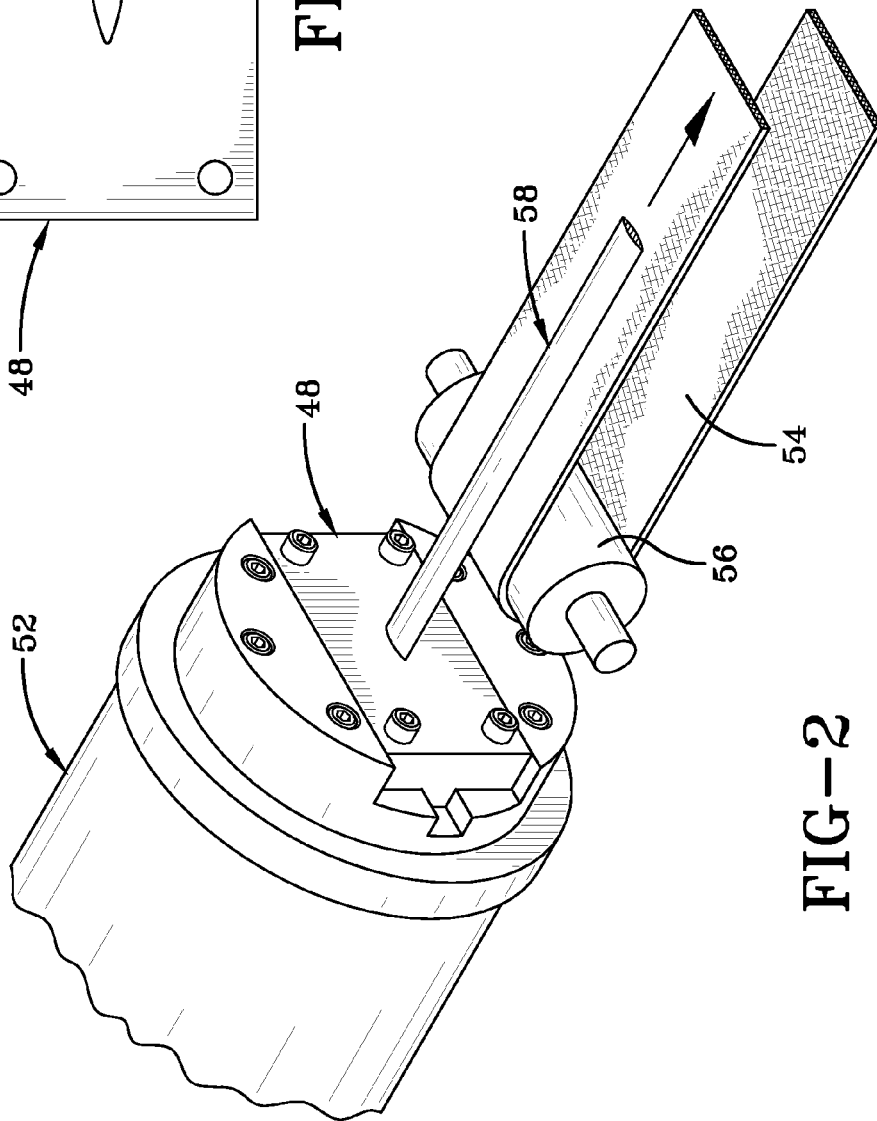
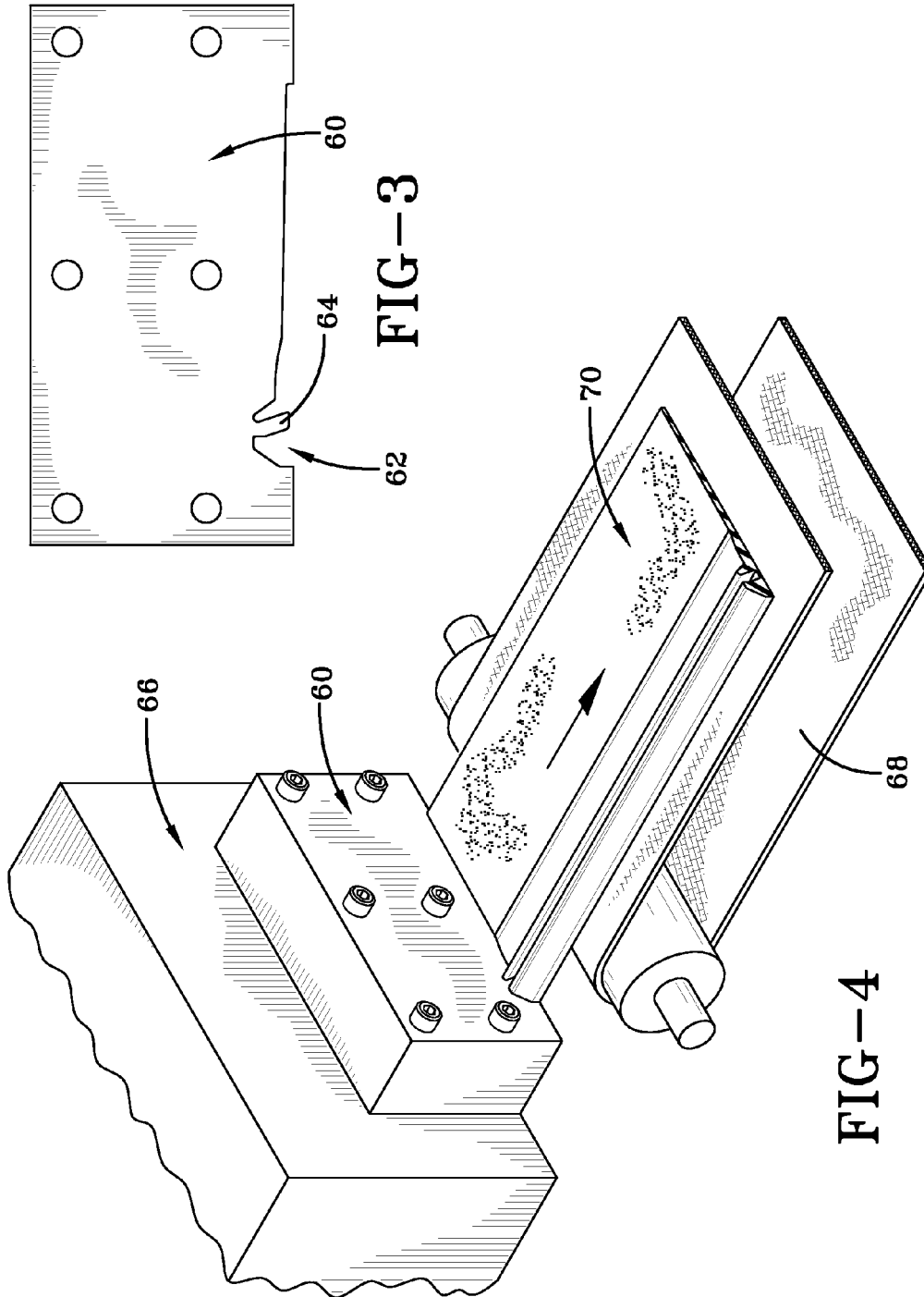

FIG-2



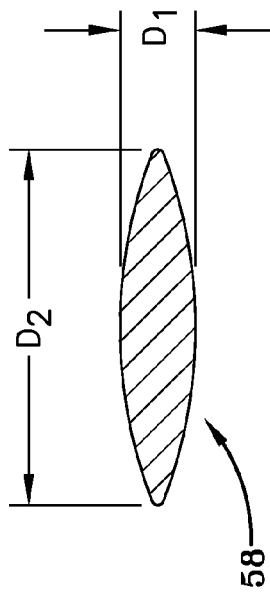

FIG-5

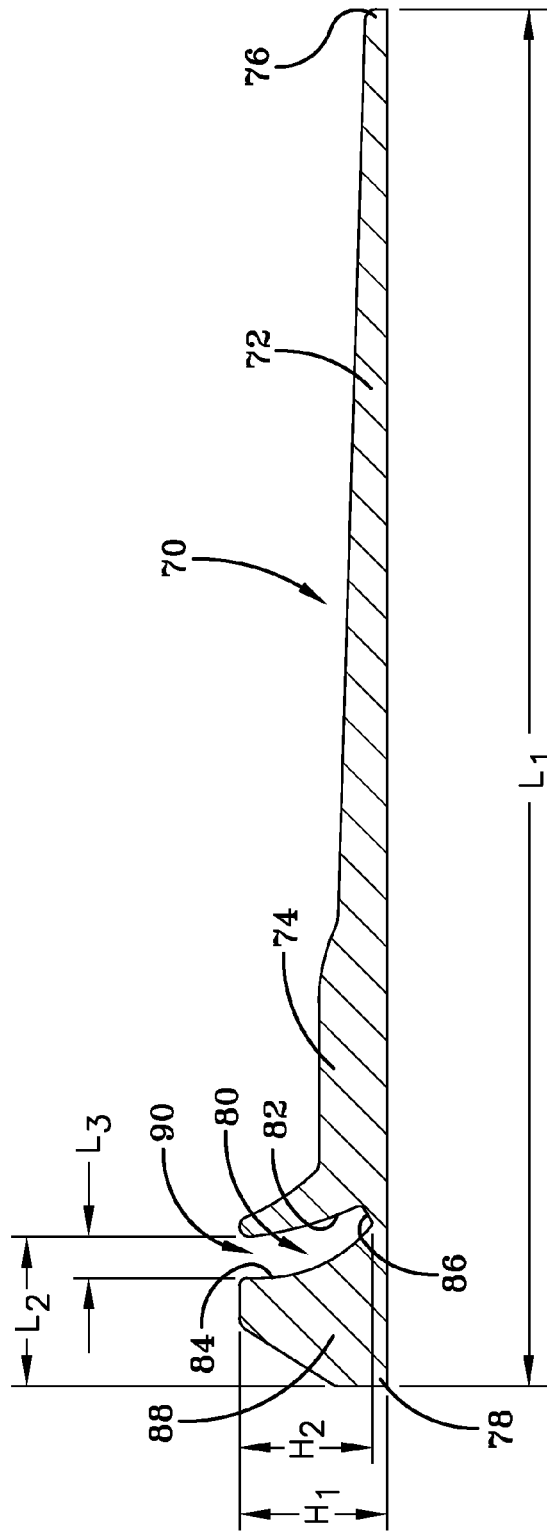

FIG-6

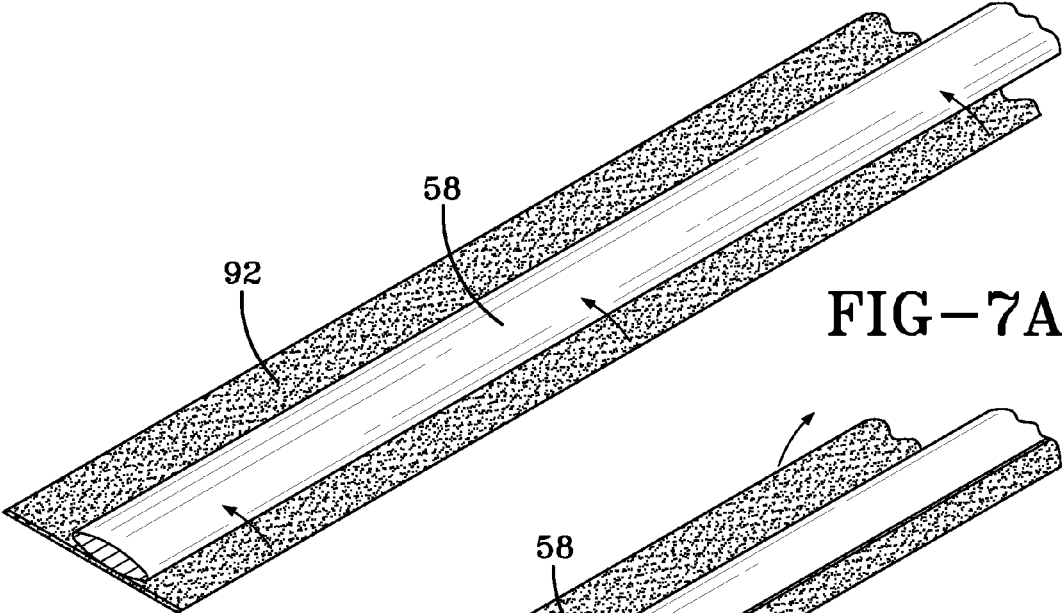

FIG-7A

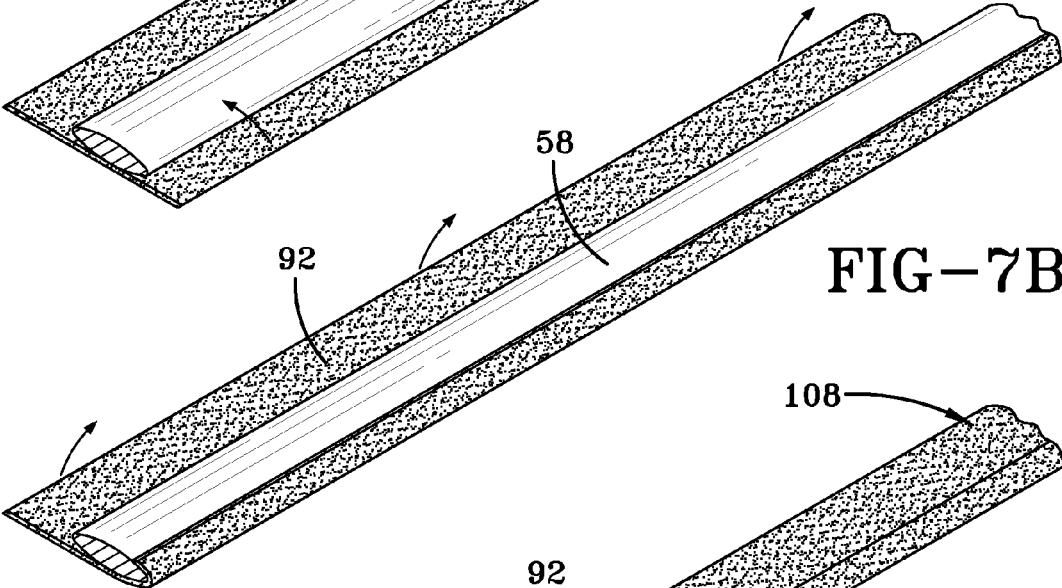

FIG-7B

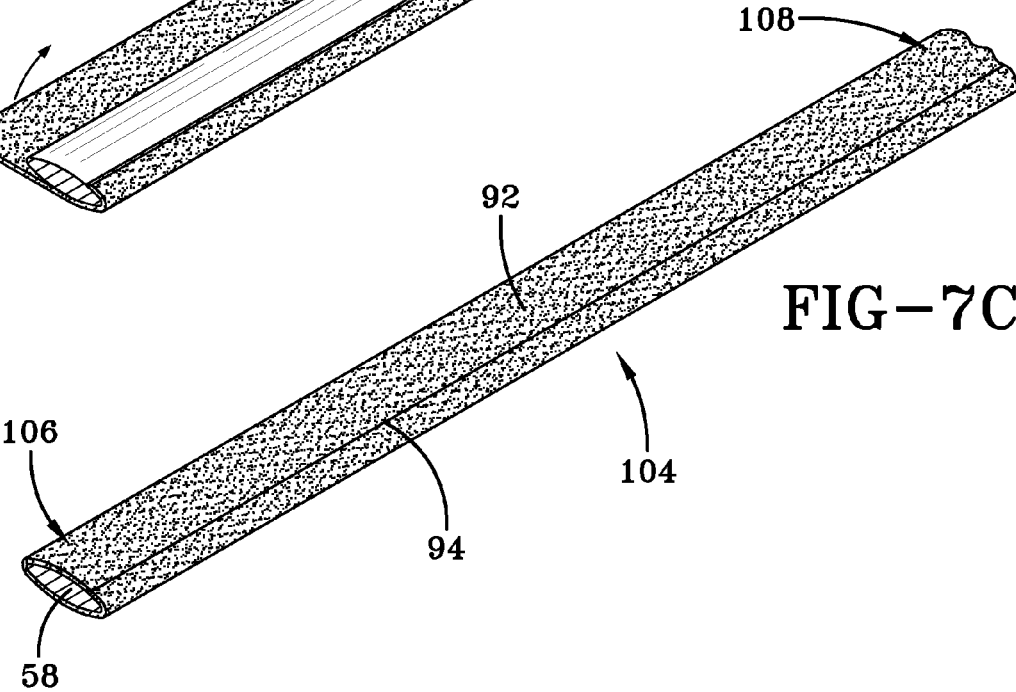
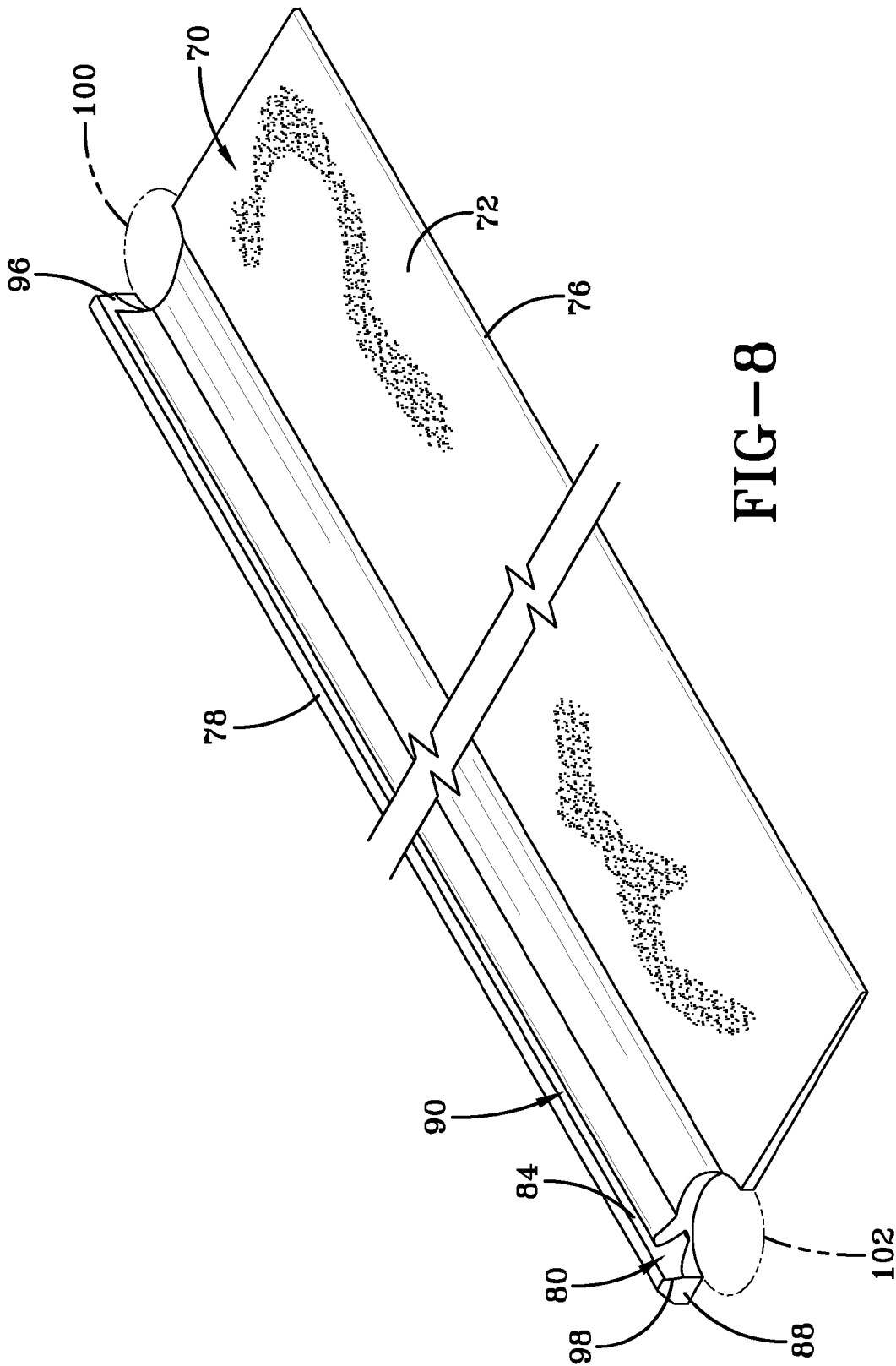
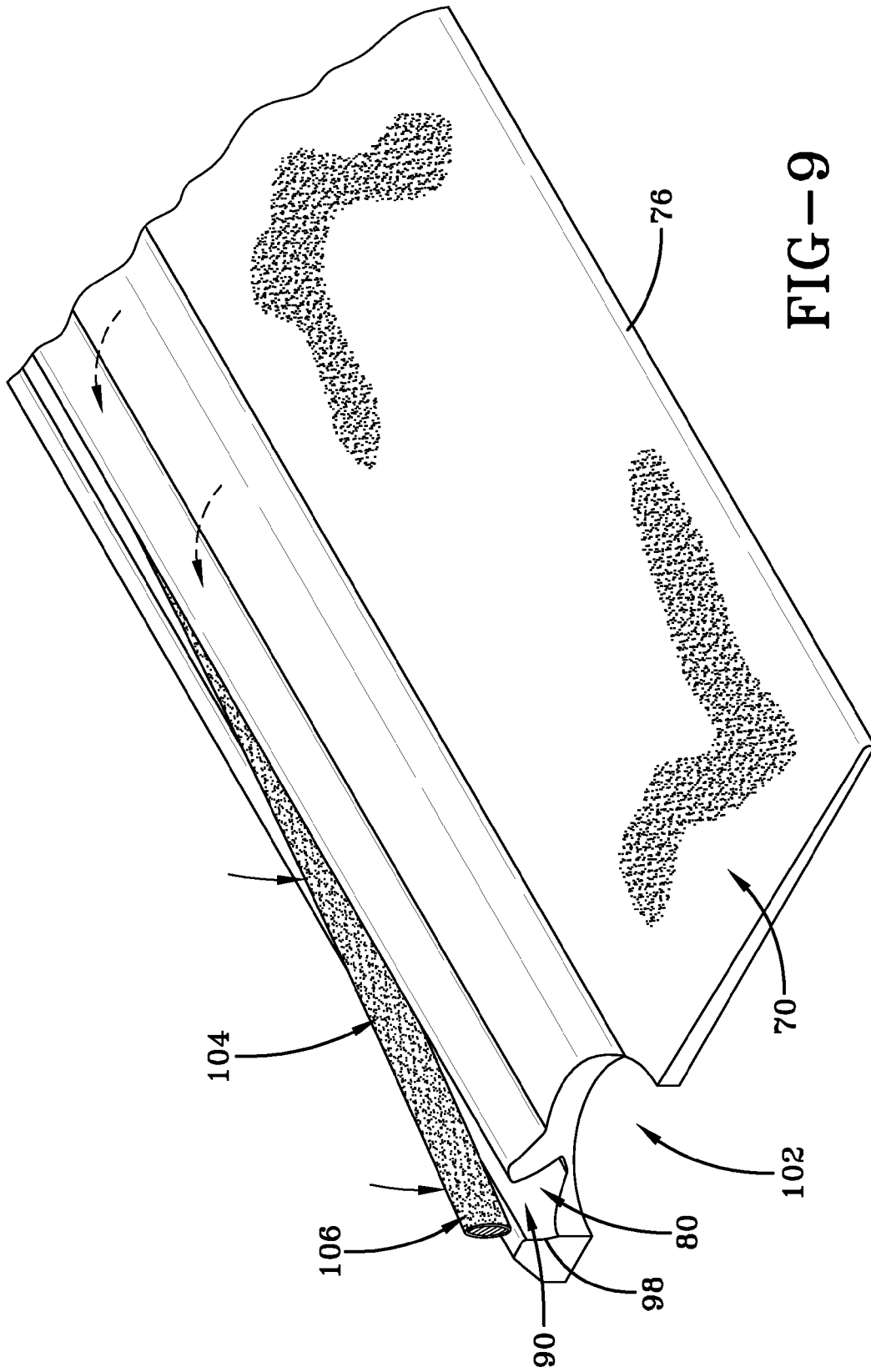

FIG-7C





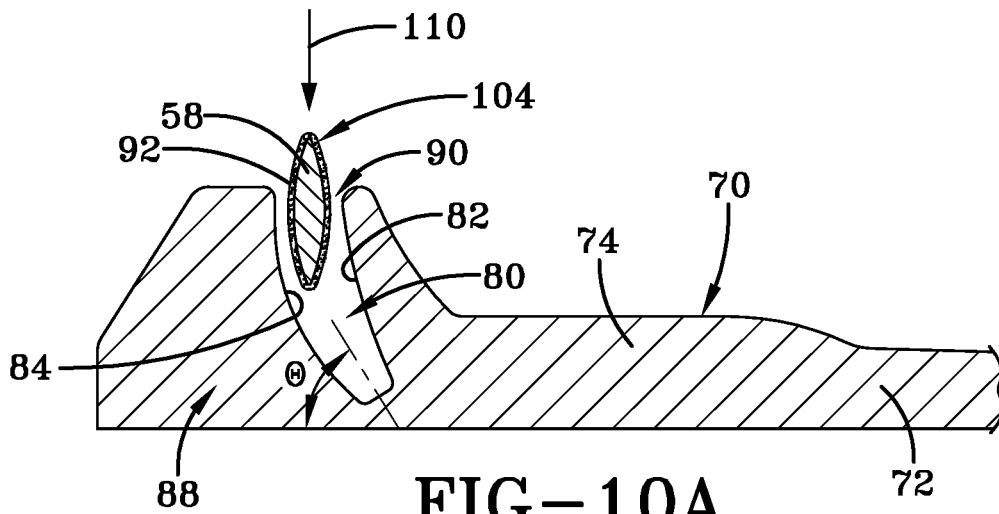

FIG-10A

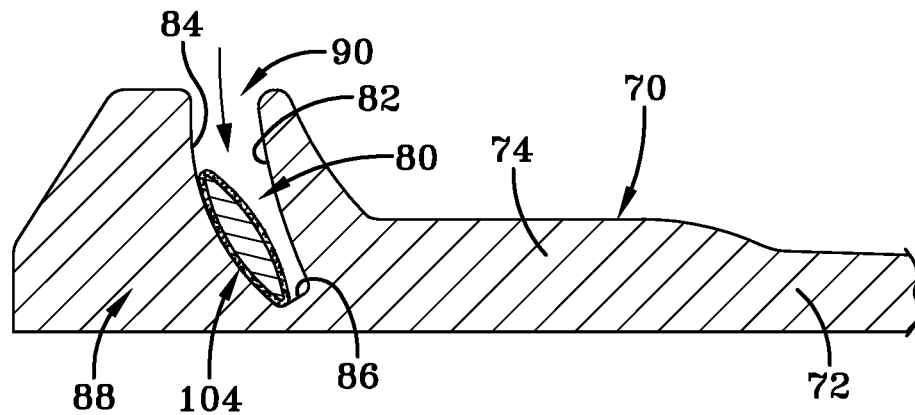

FIG-10B

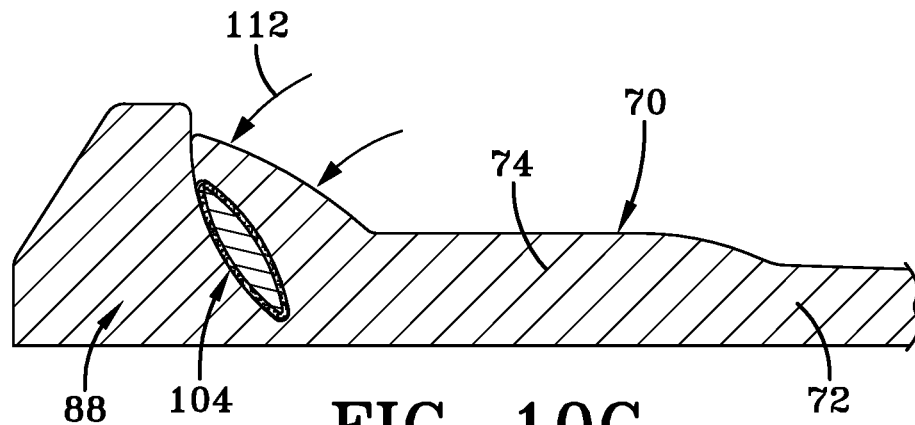

FIG-10C

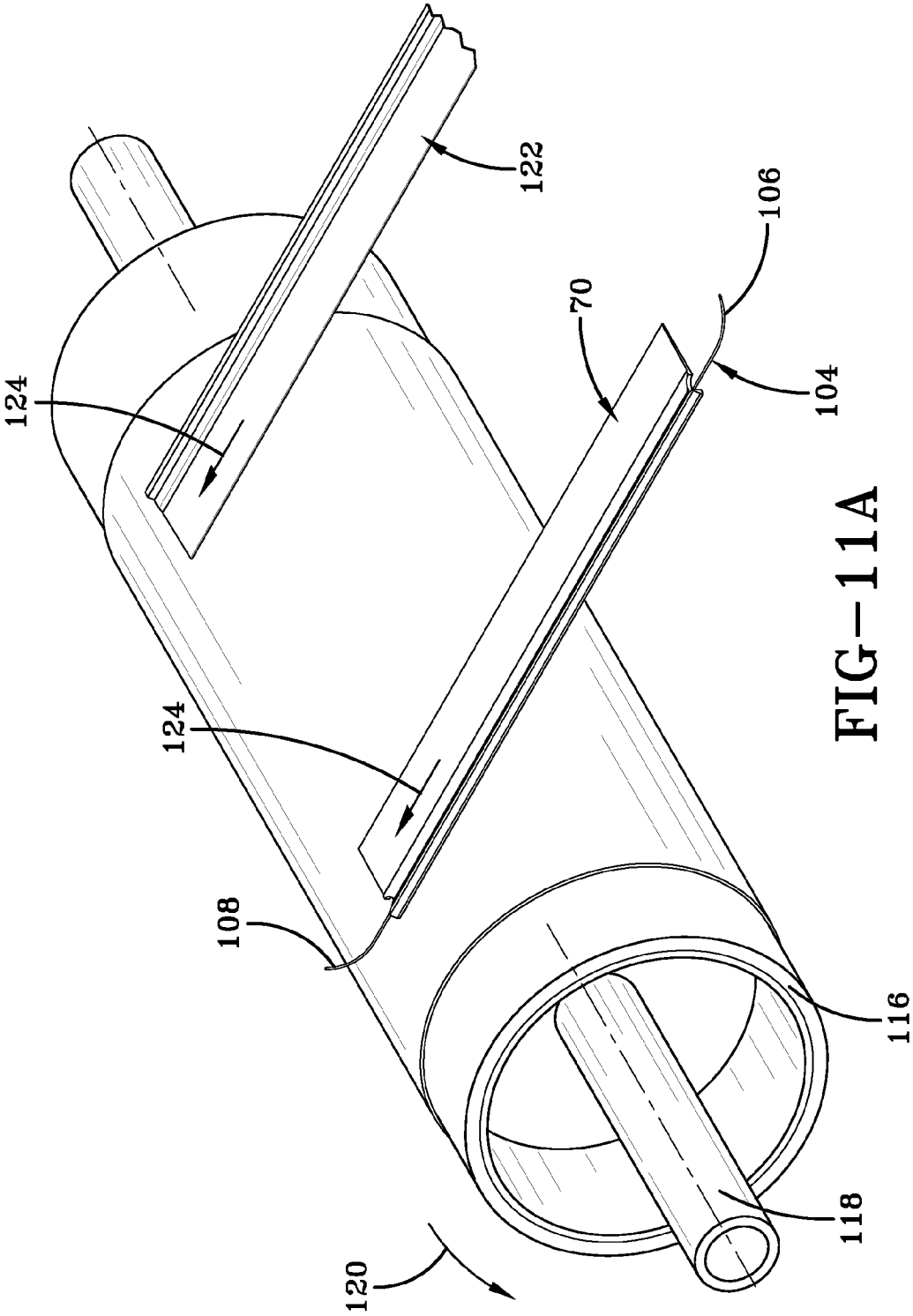

FIG-11A

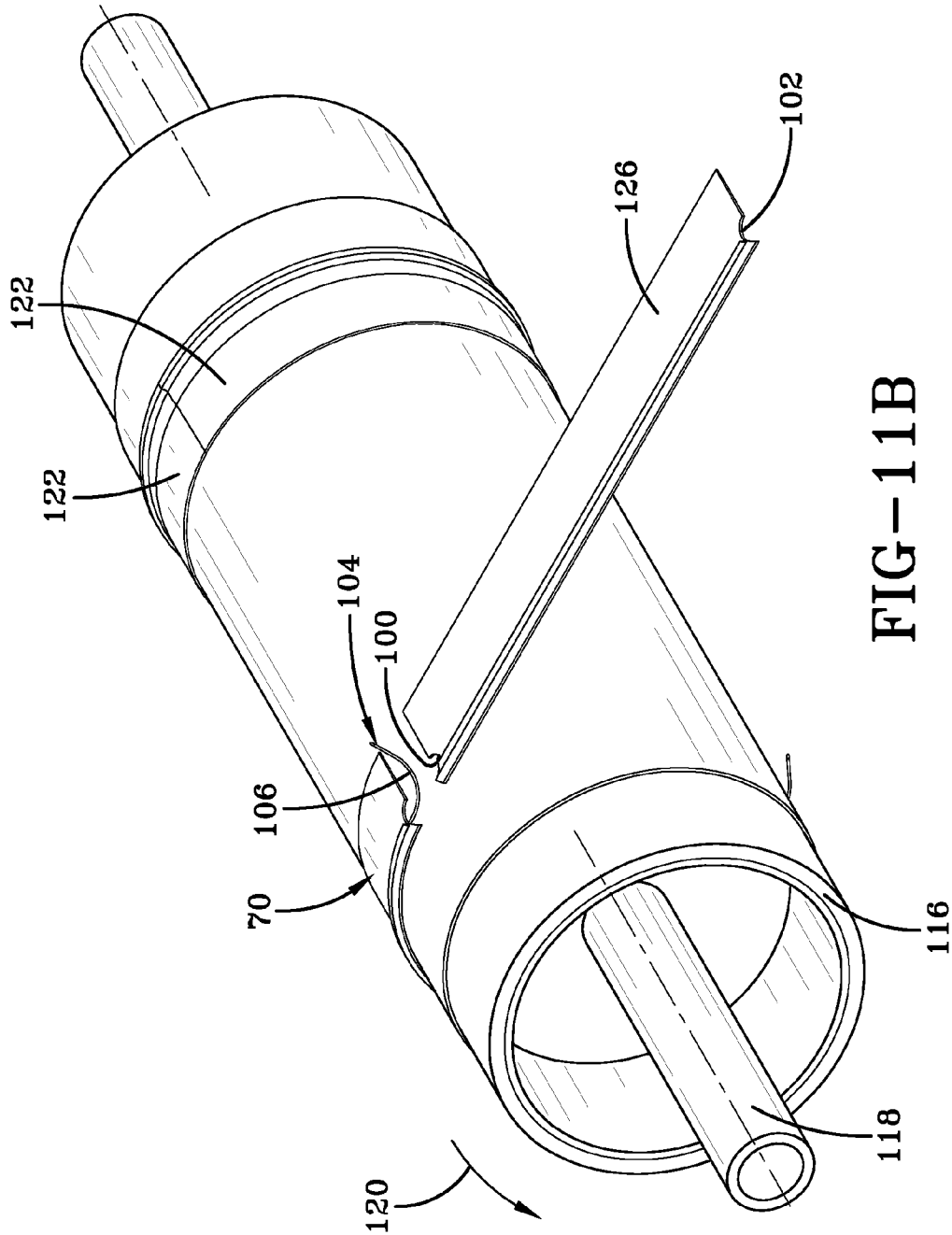

FIG-11B

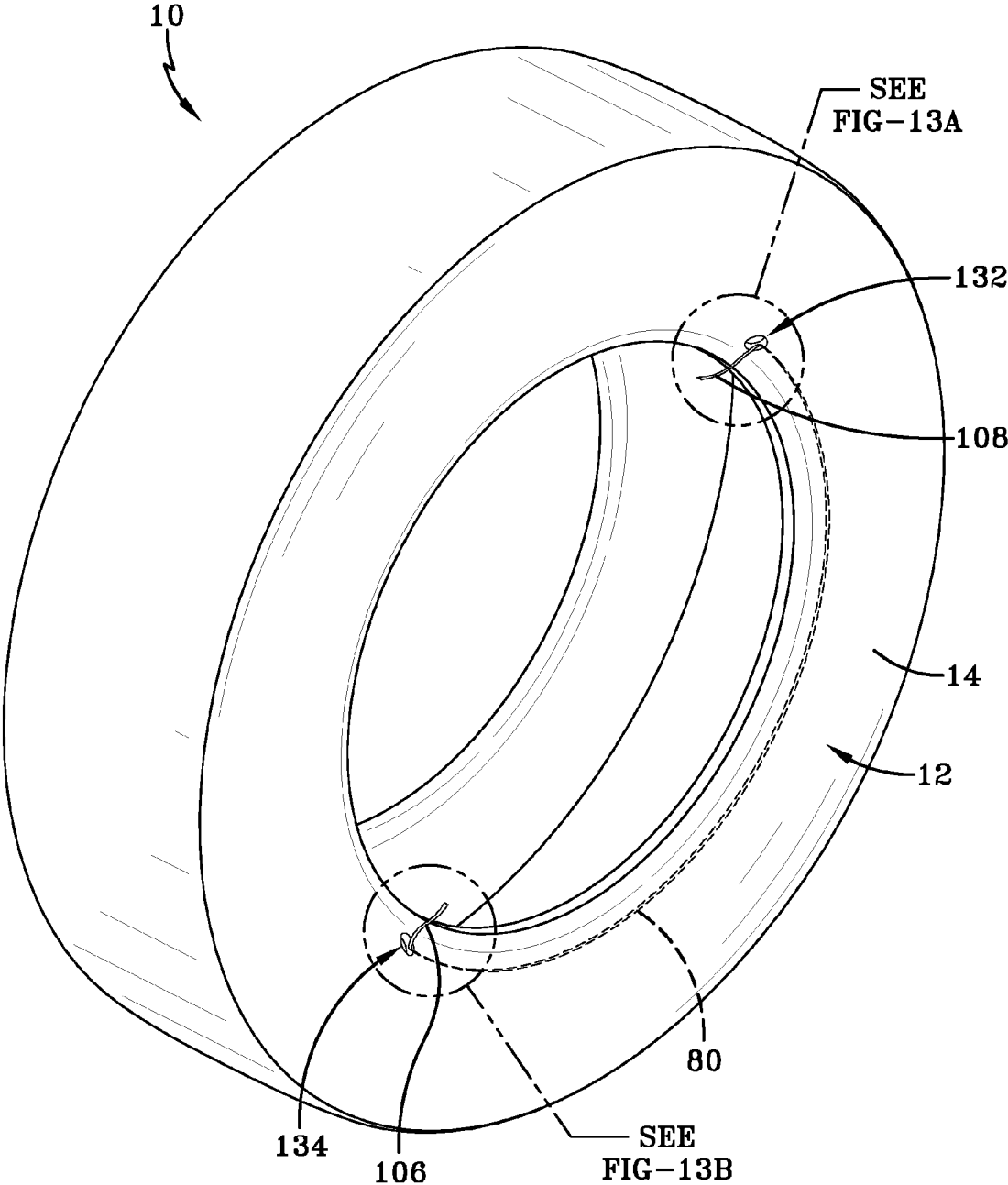

FIG-12

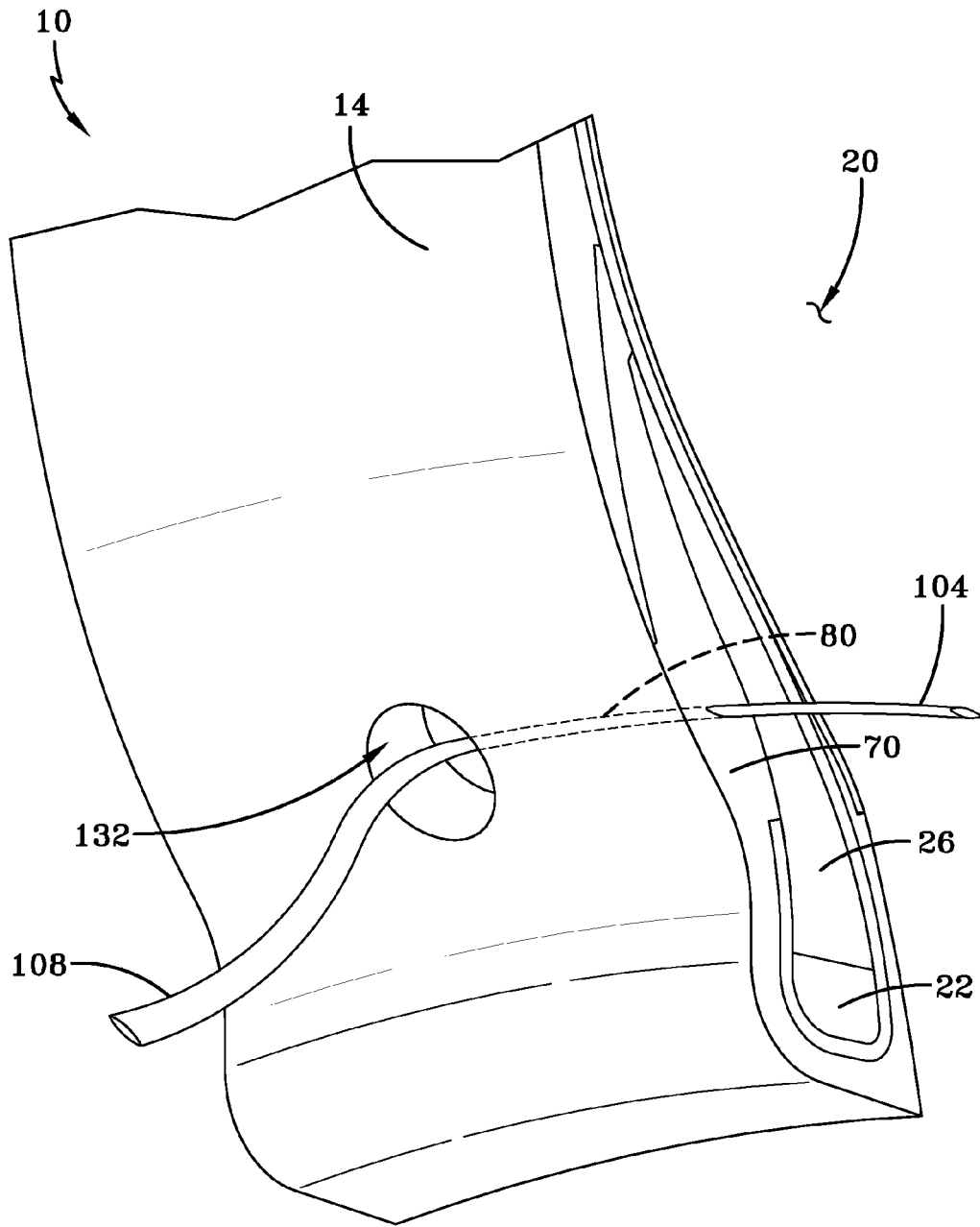

FIG-13A

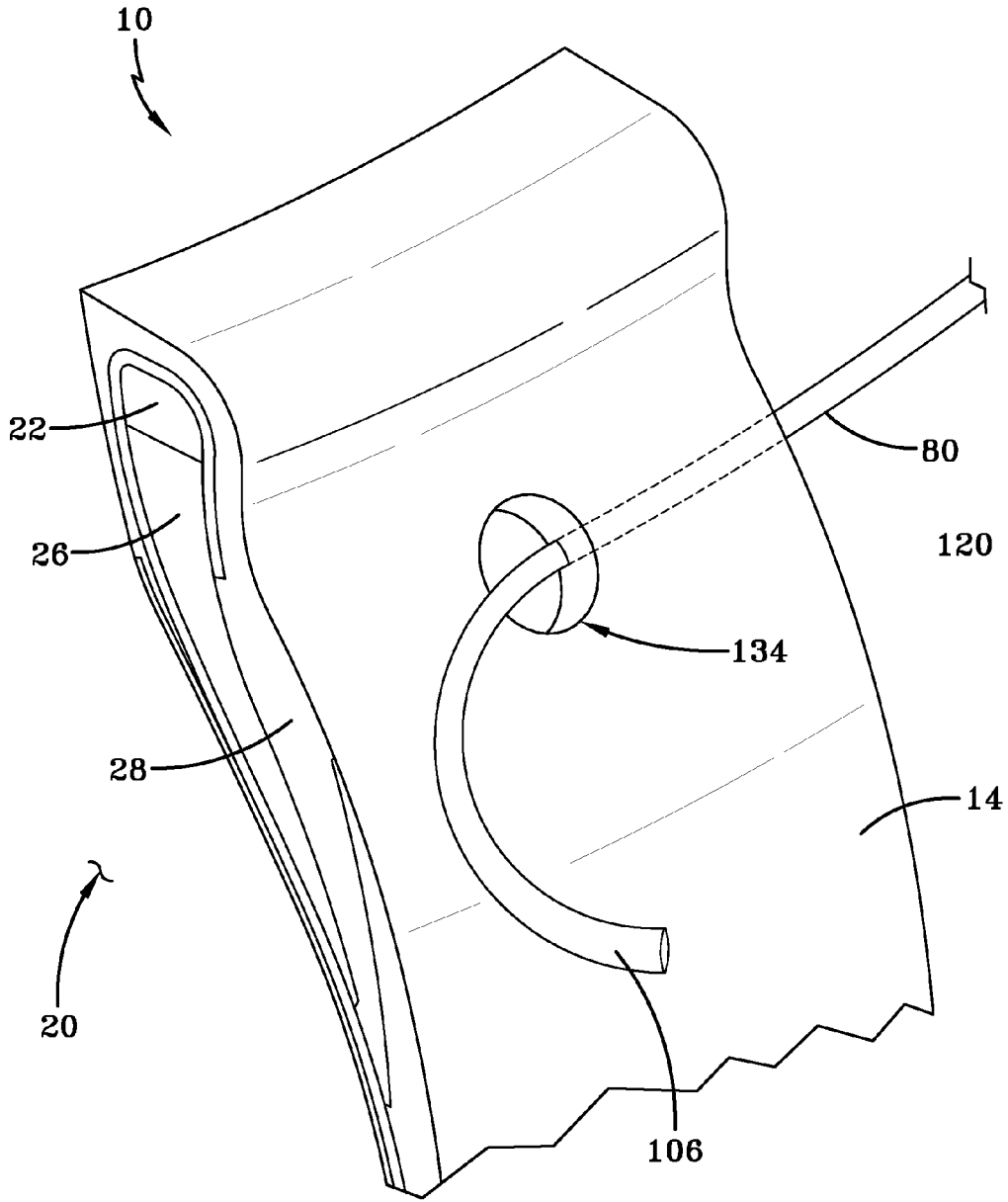
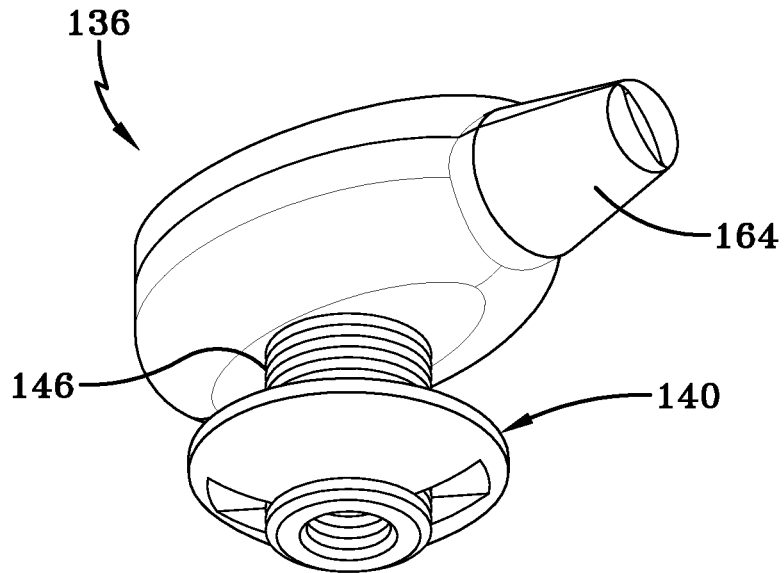
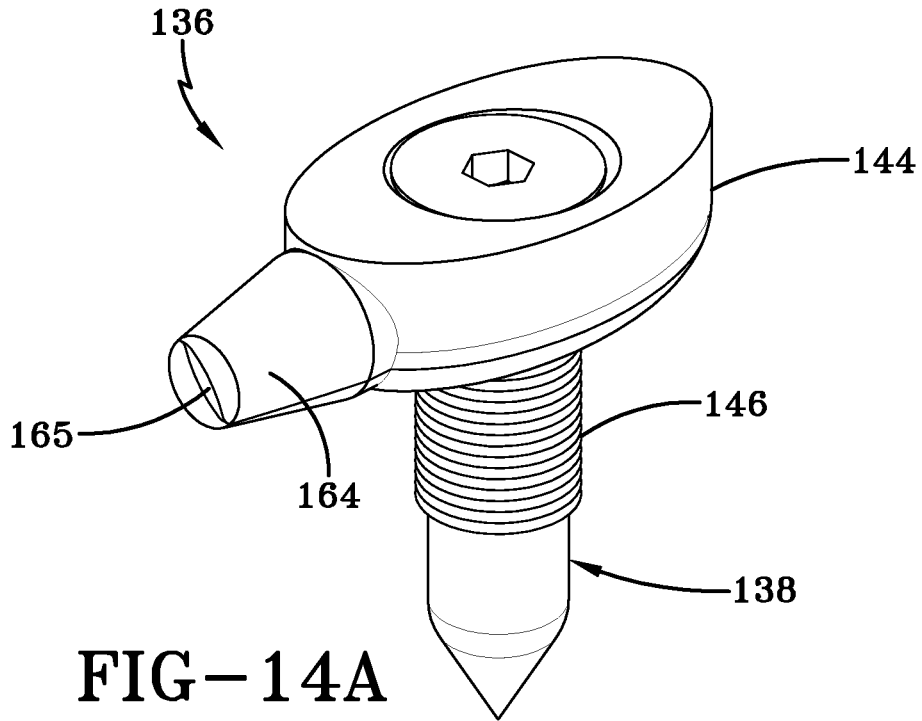

FIG-13B



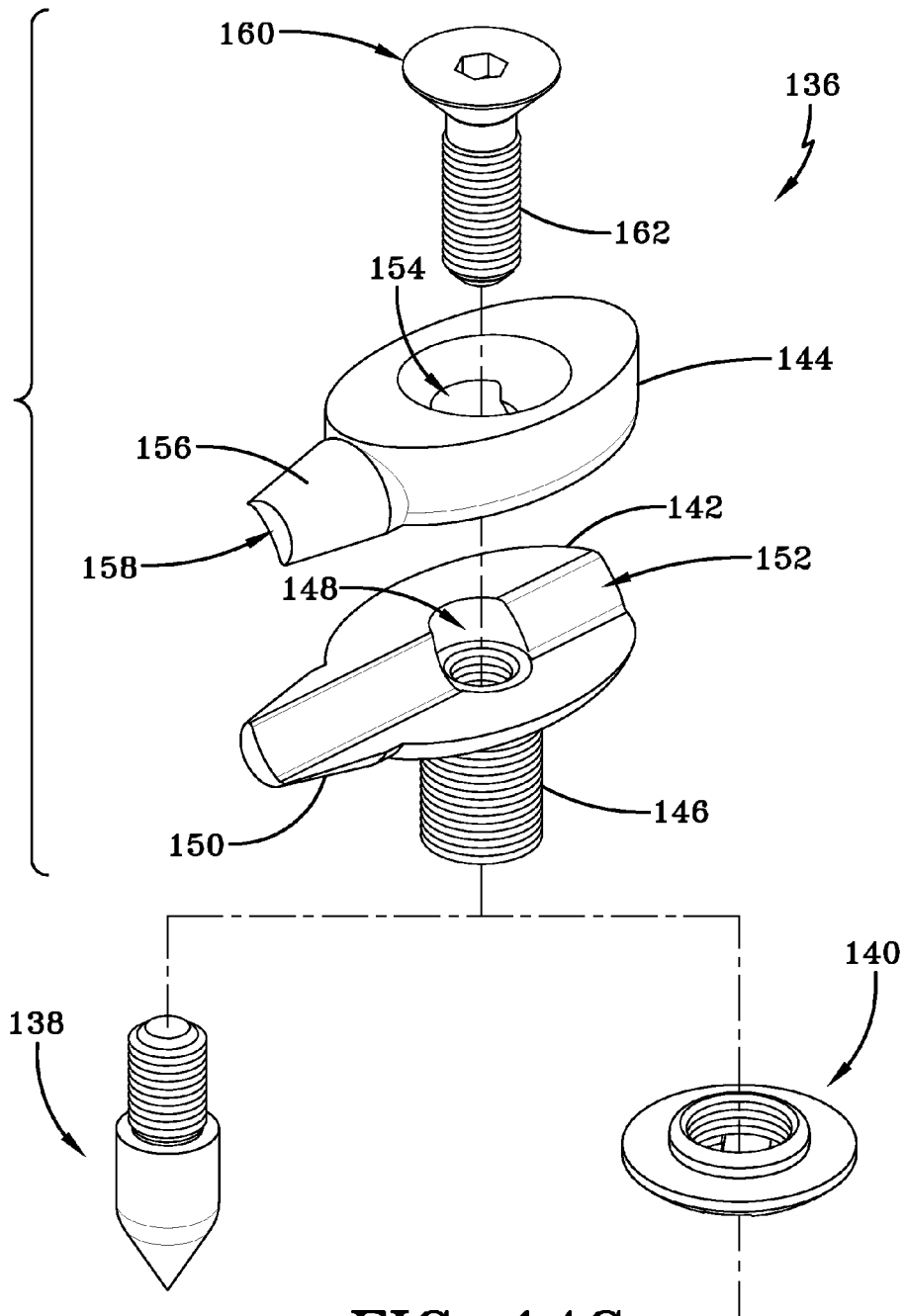
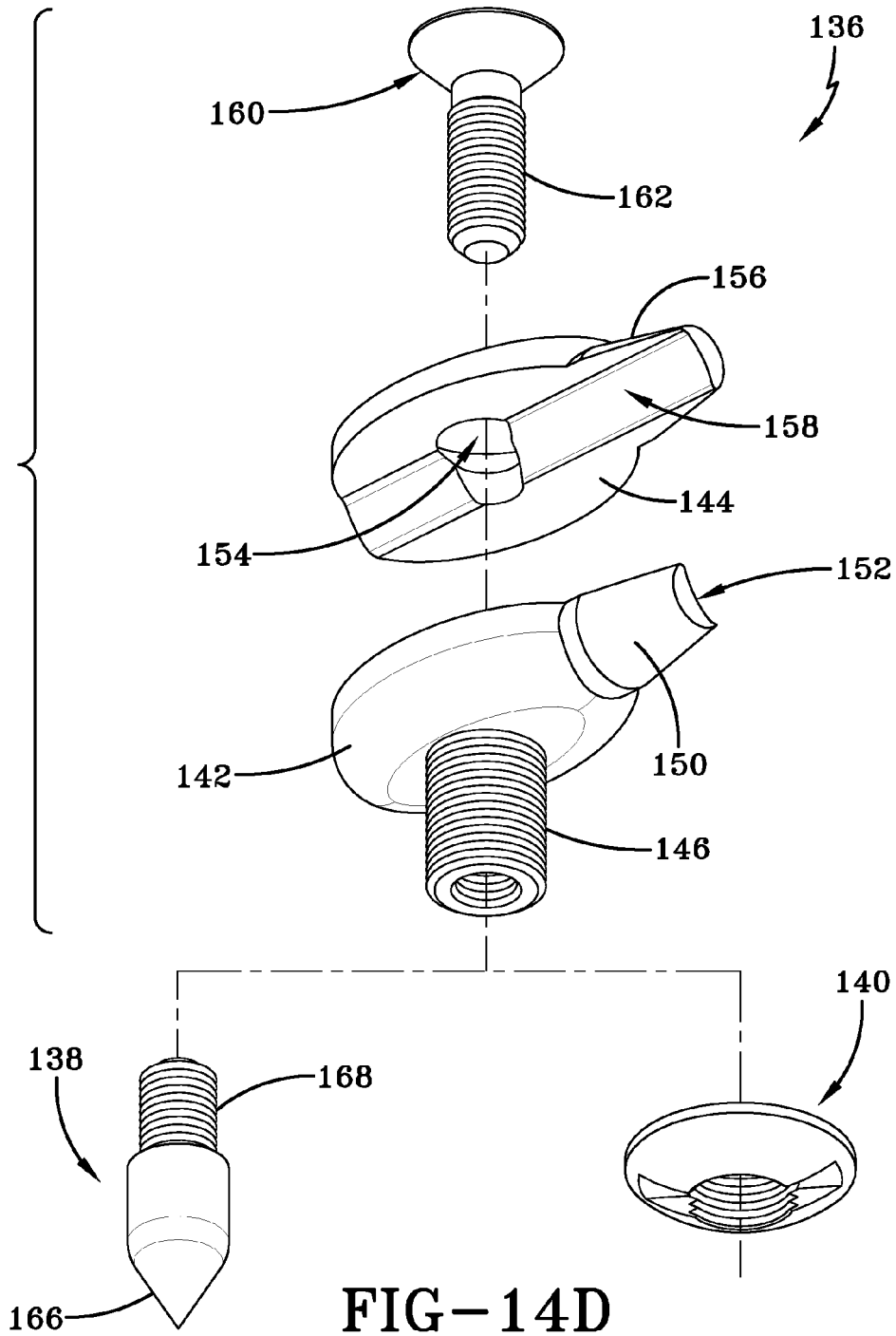

FIG-14C



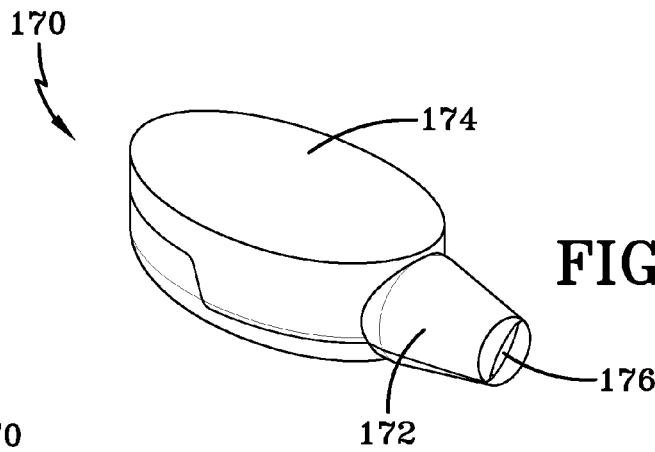

FIG-15A

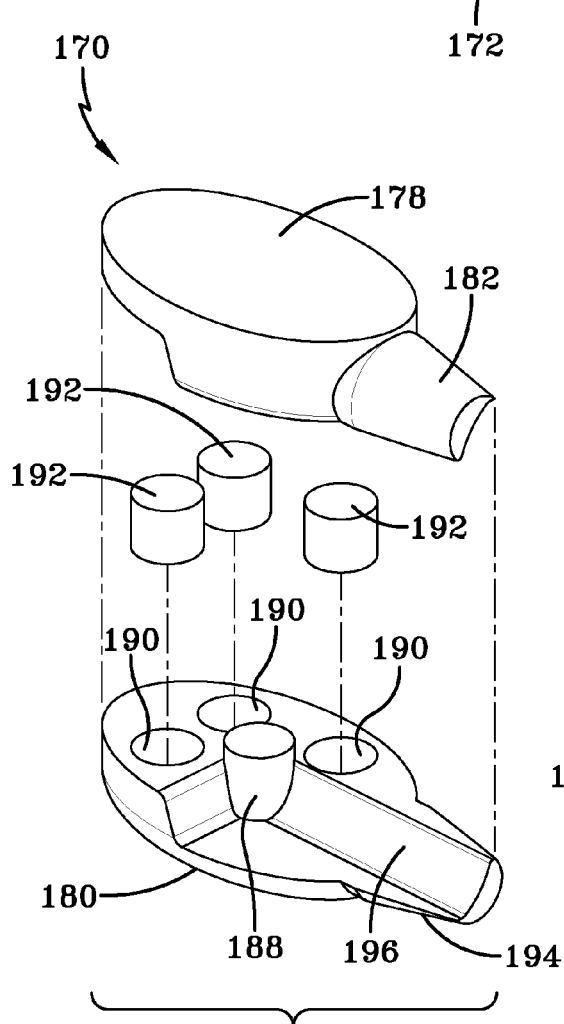

FIG-15B

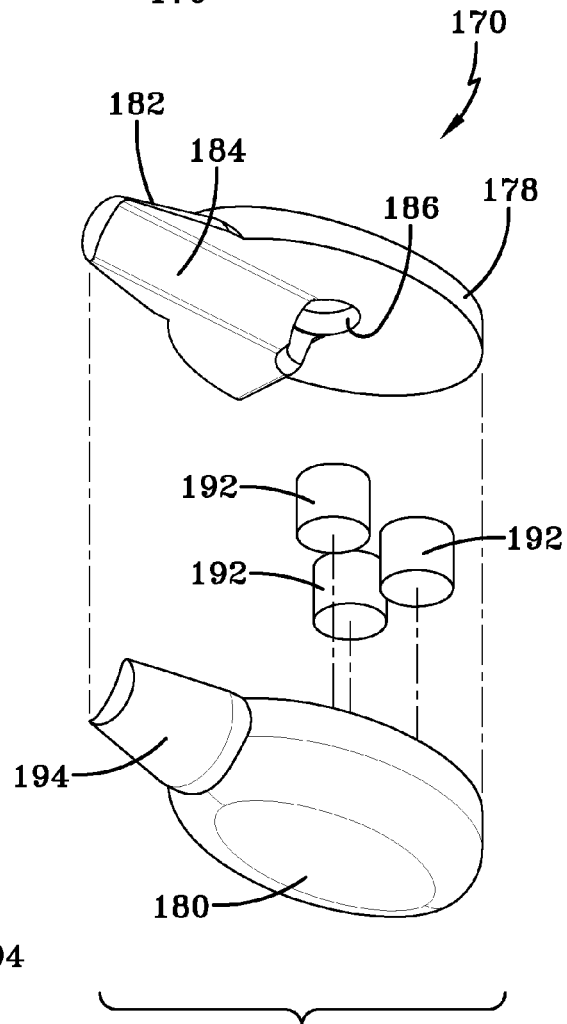

FIG-15C

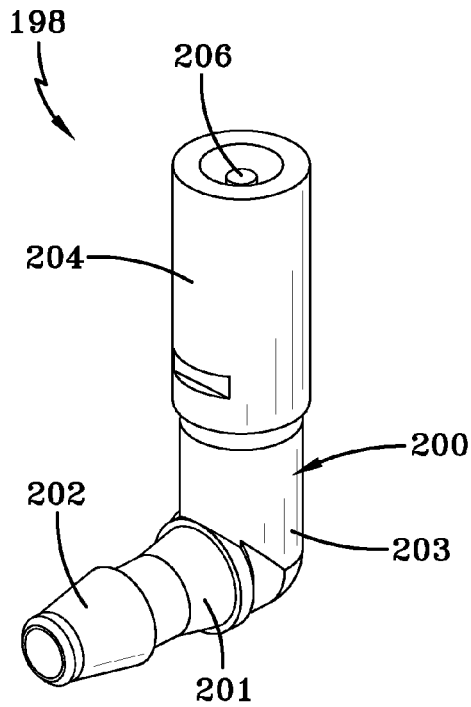

FIG-16A

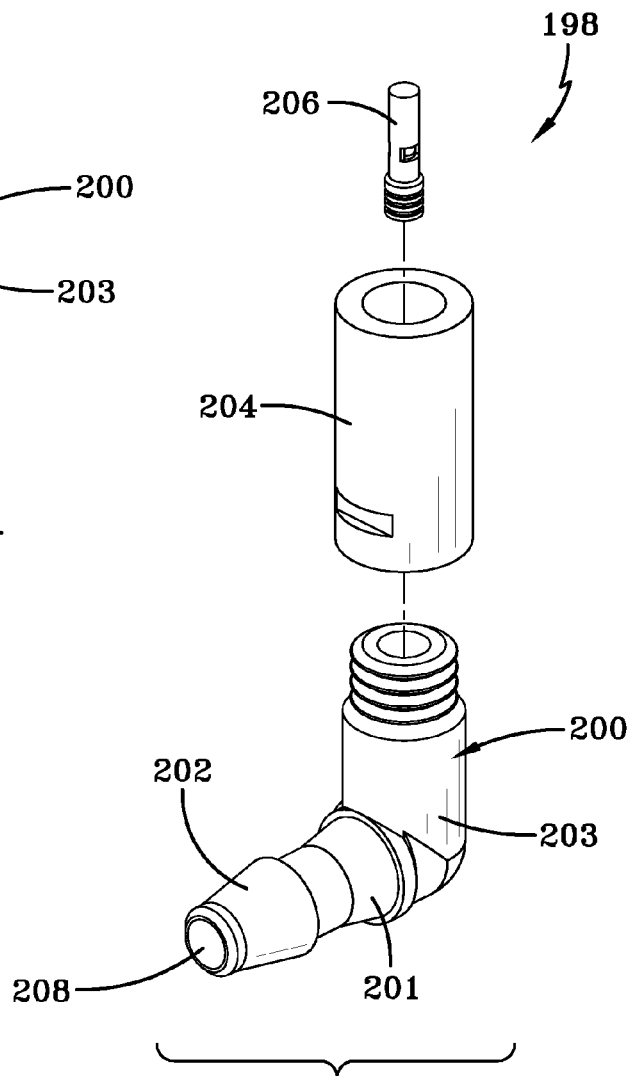

FIG-16B

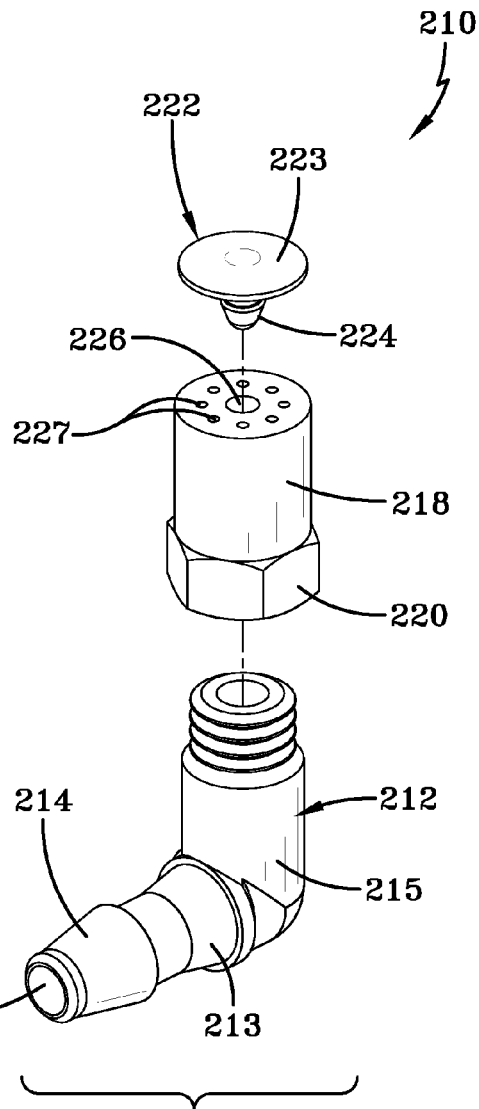
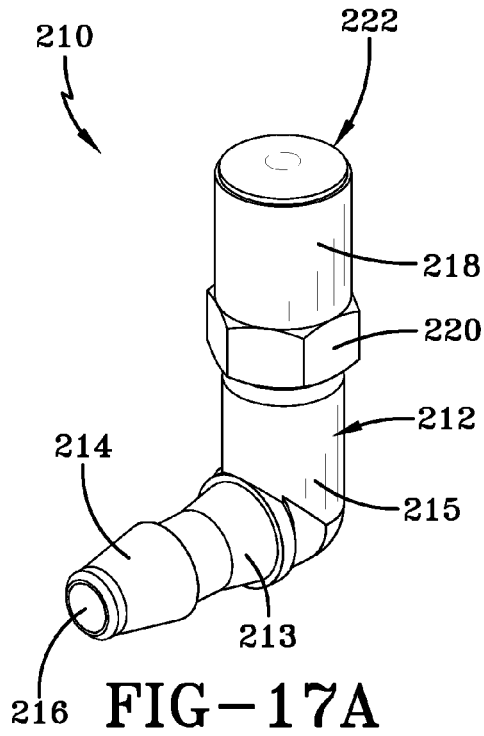

FIG-17B

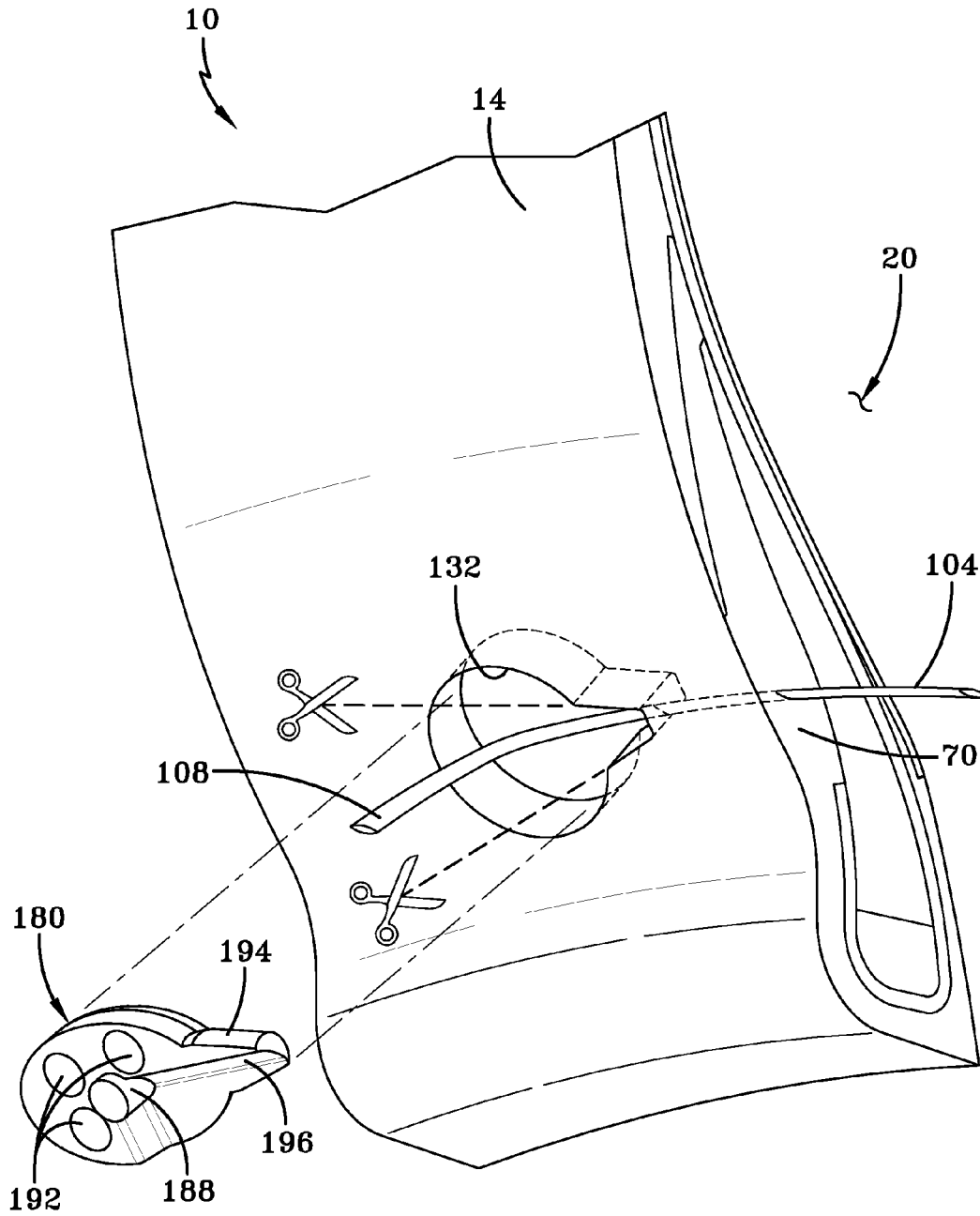

FIG-18A

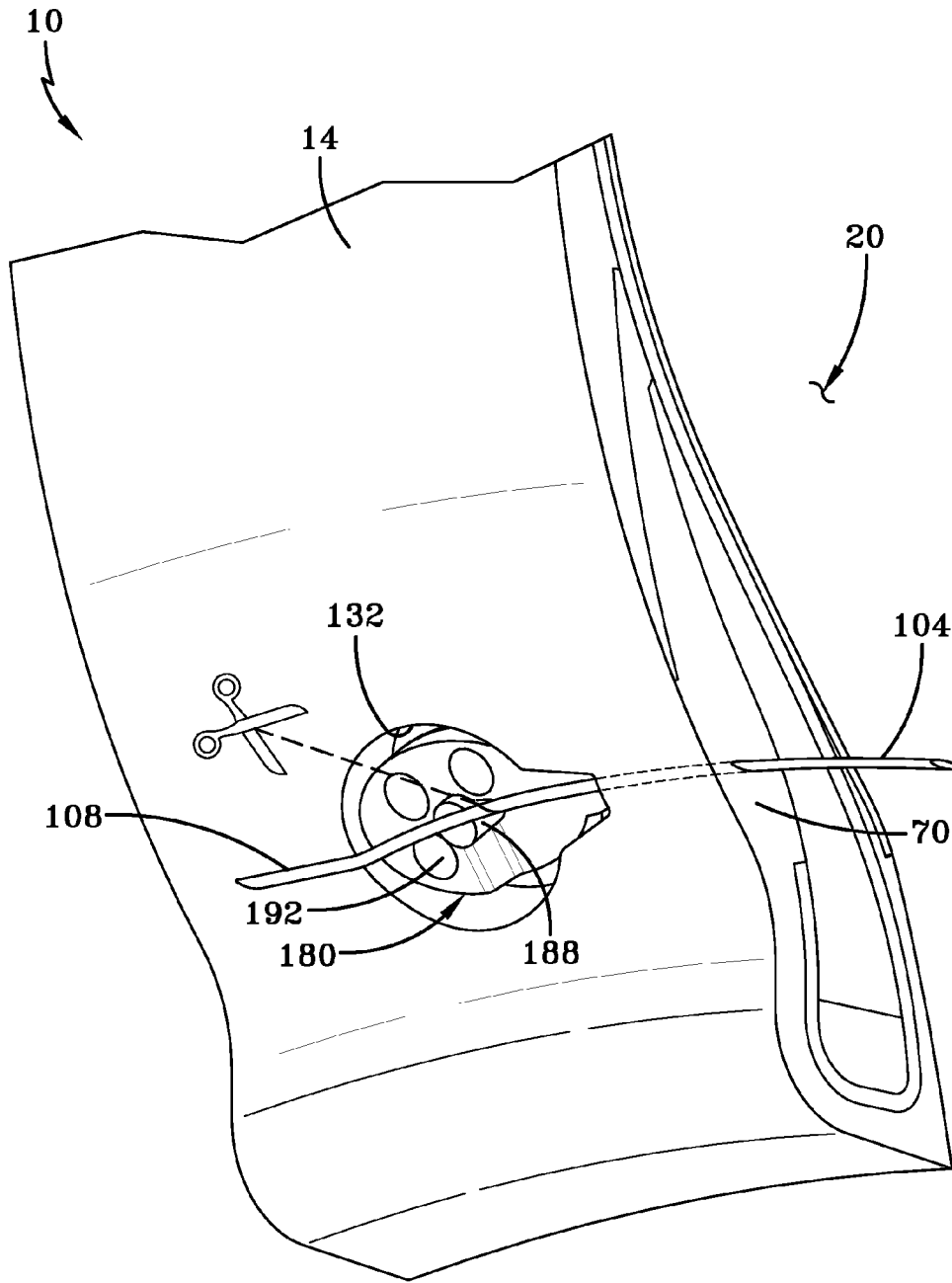

FIG-18B

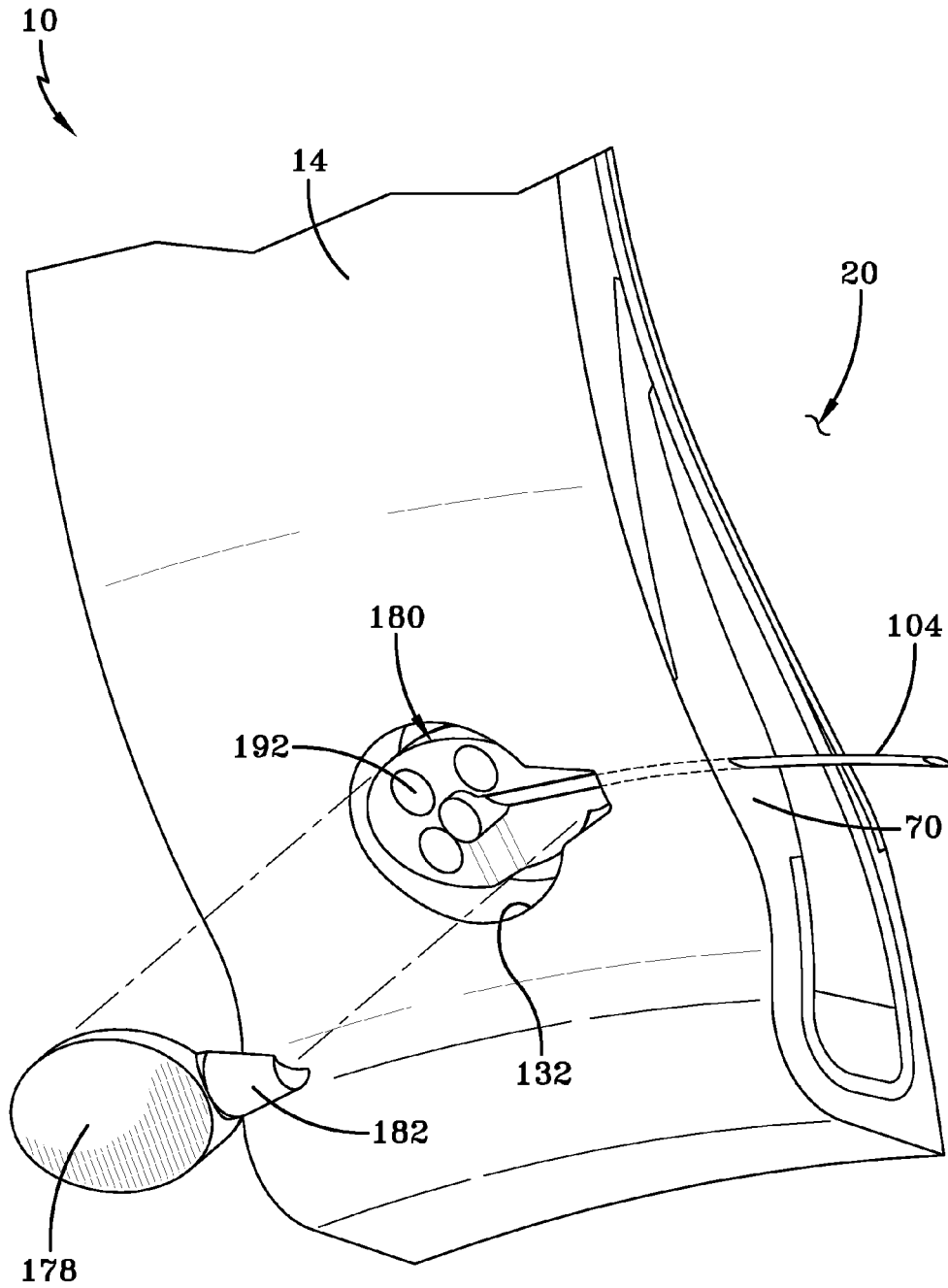

FIG-18C

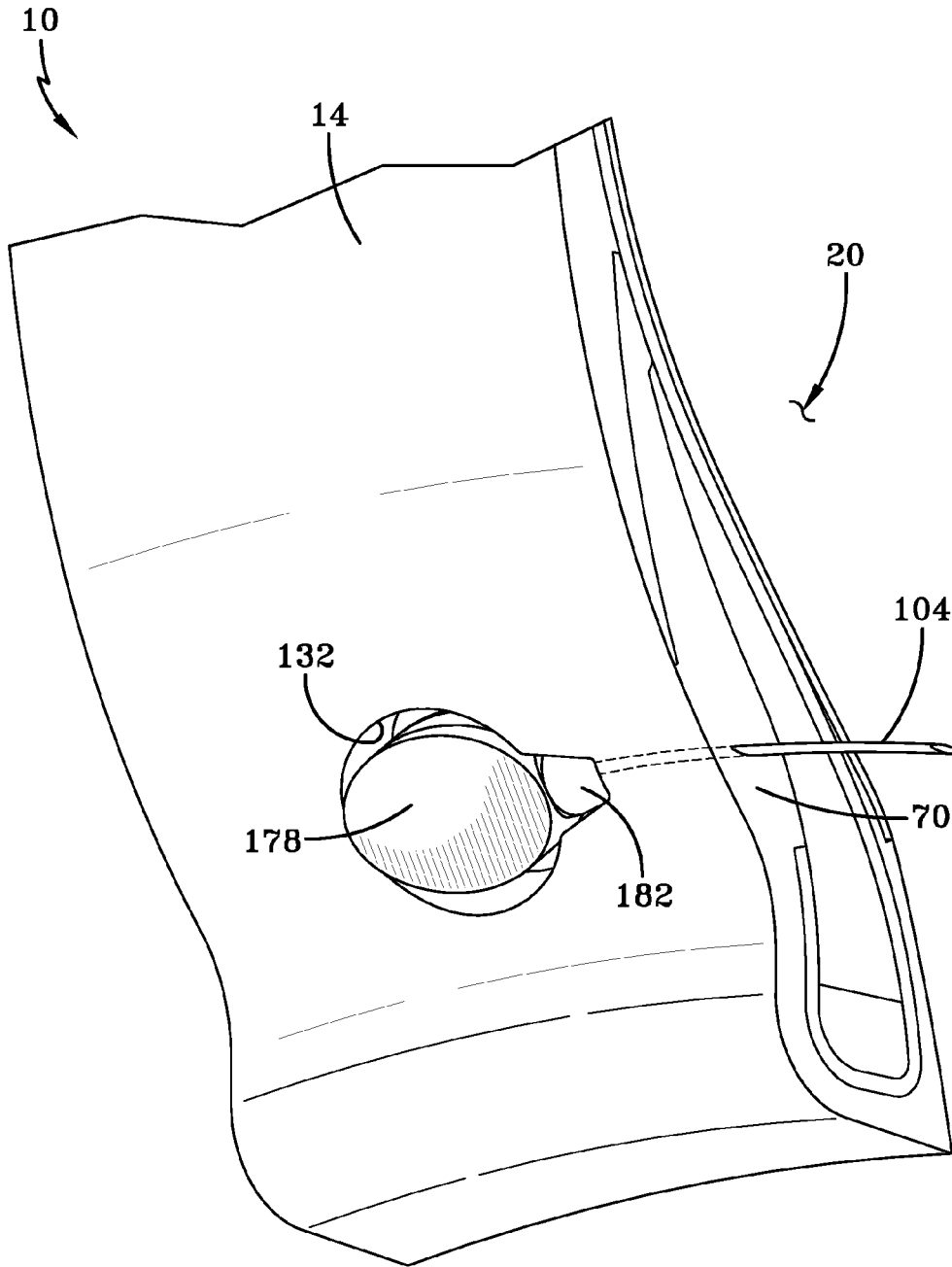

FIG-18D

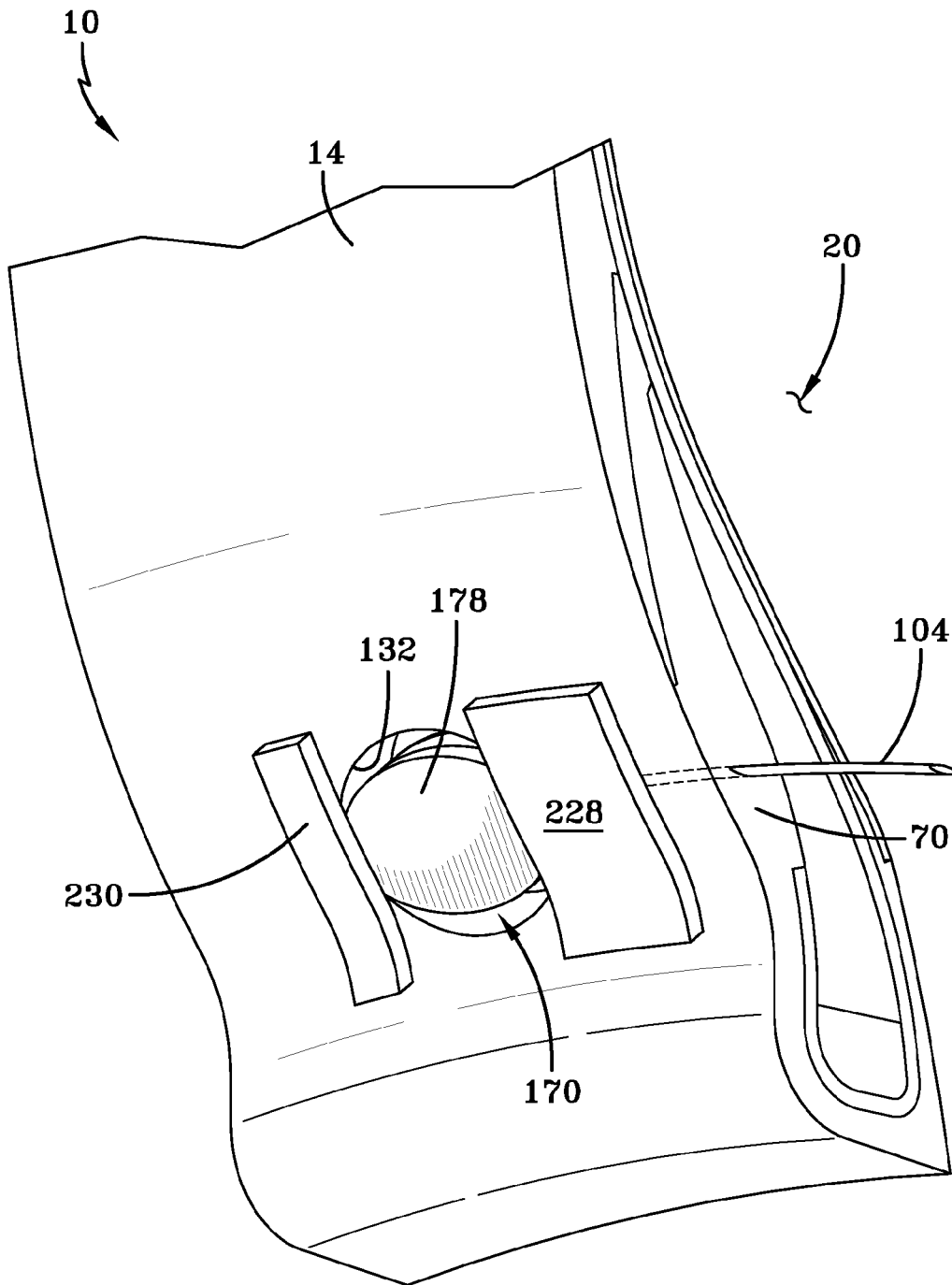

FIG-18E

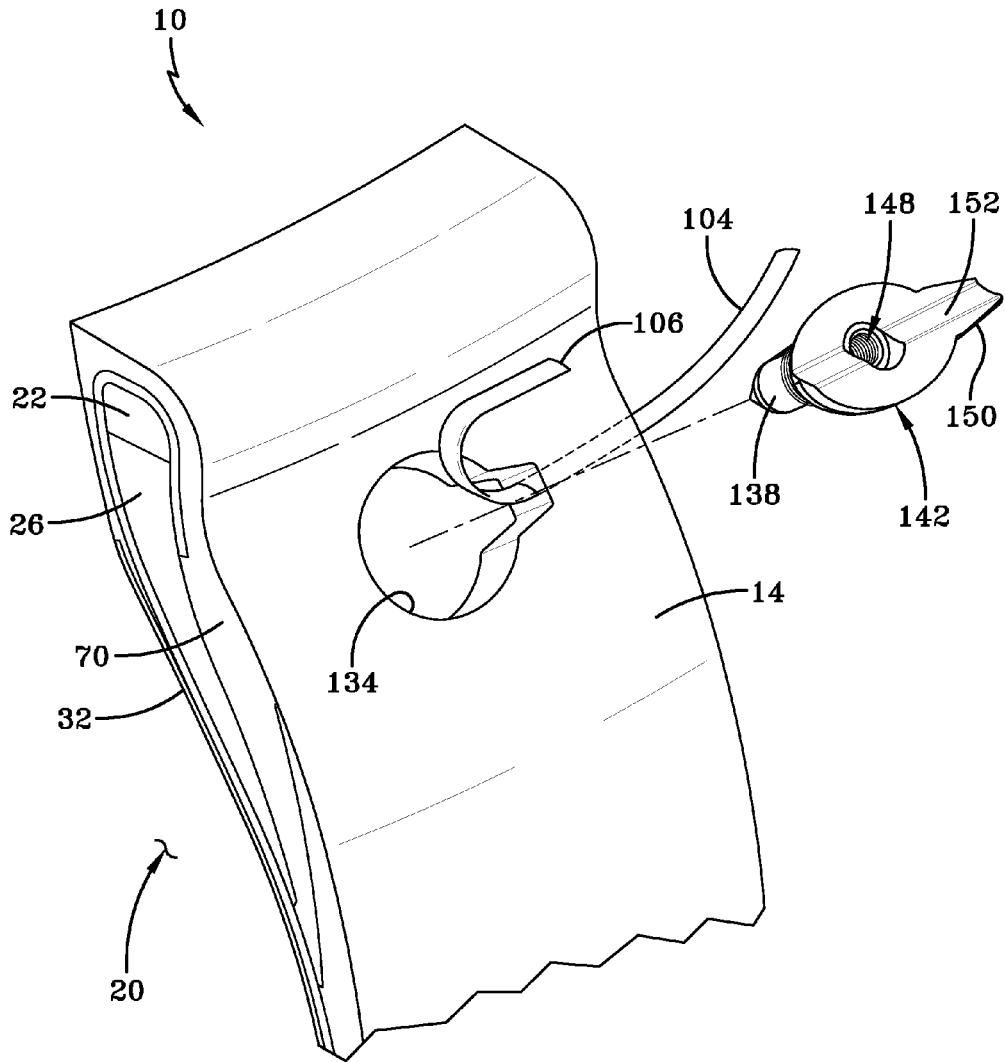

FIG-19A

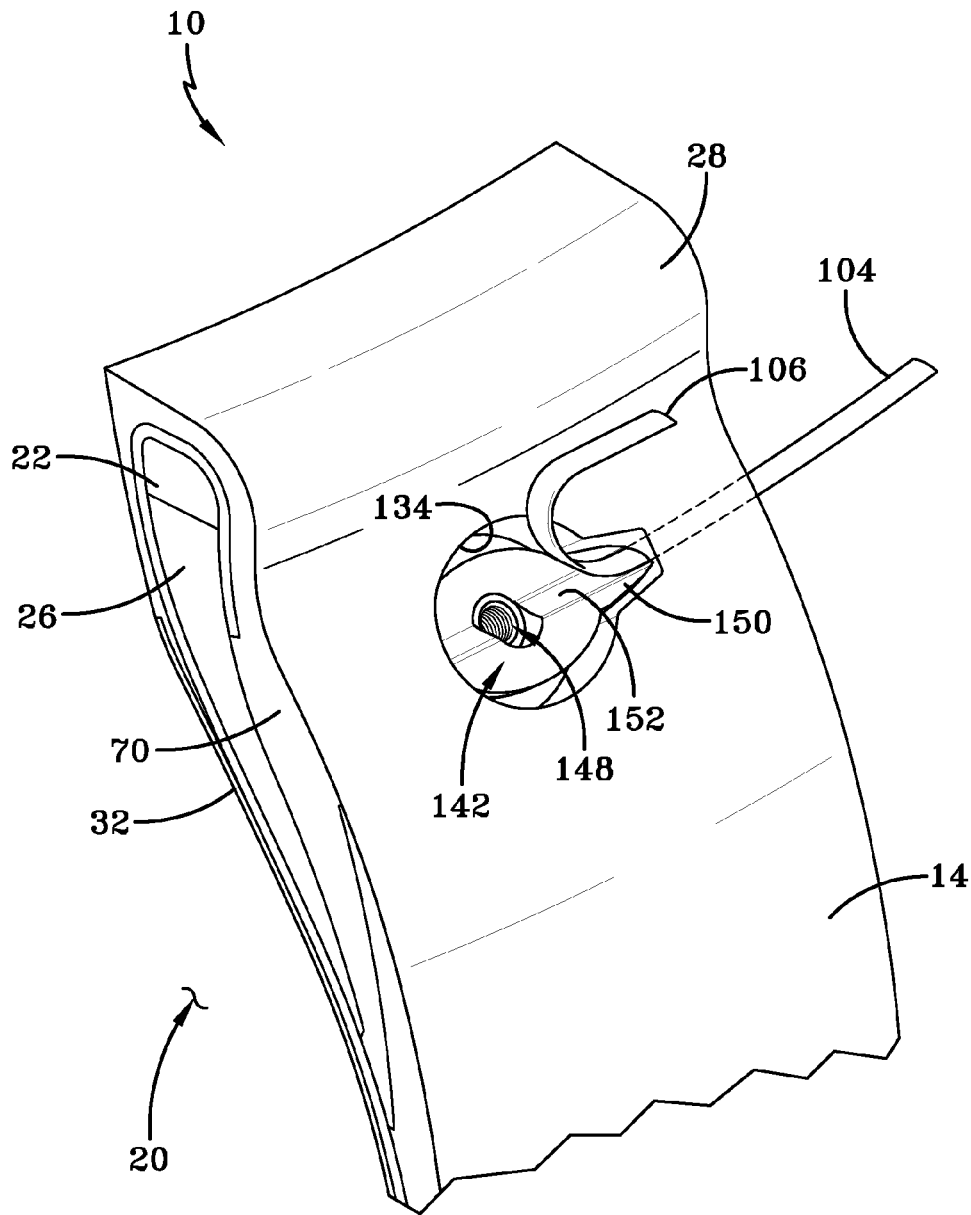

FIG-19B

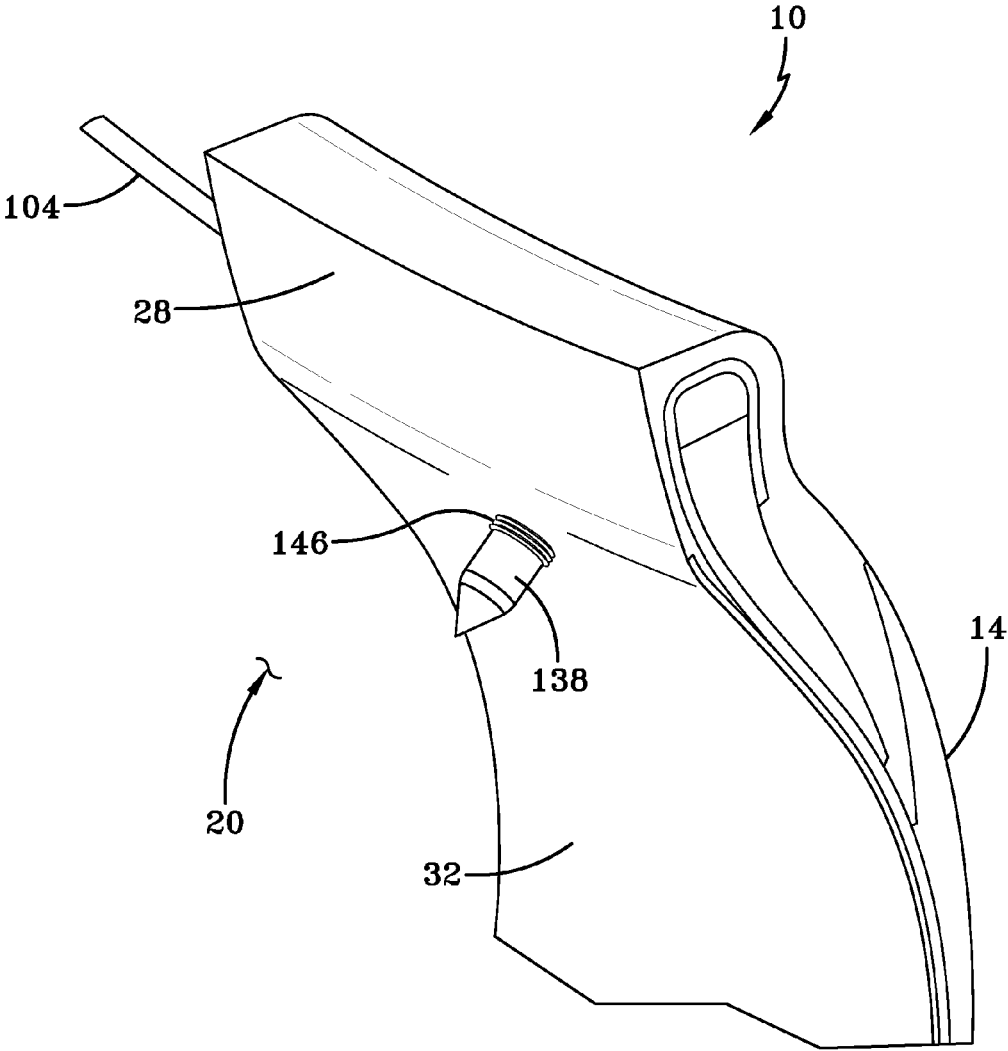

FIG-19C

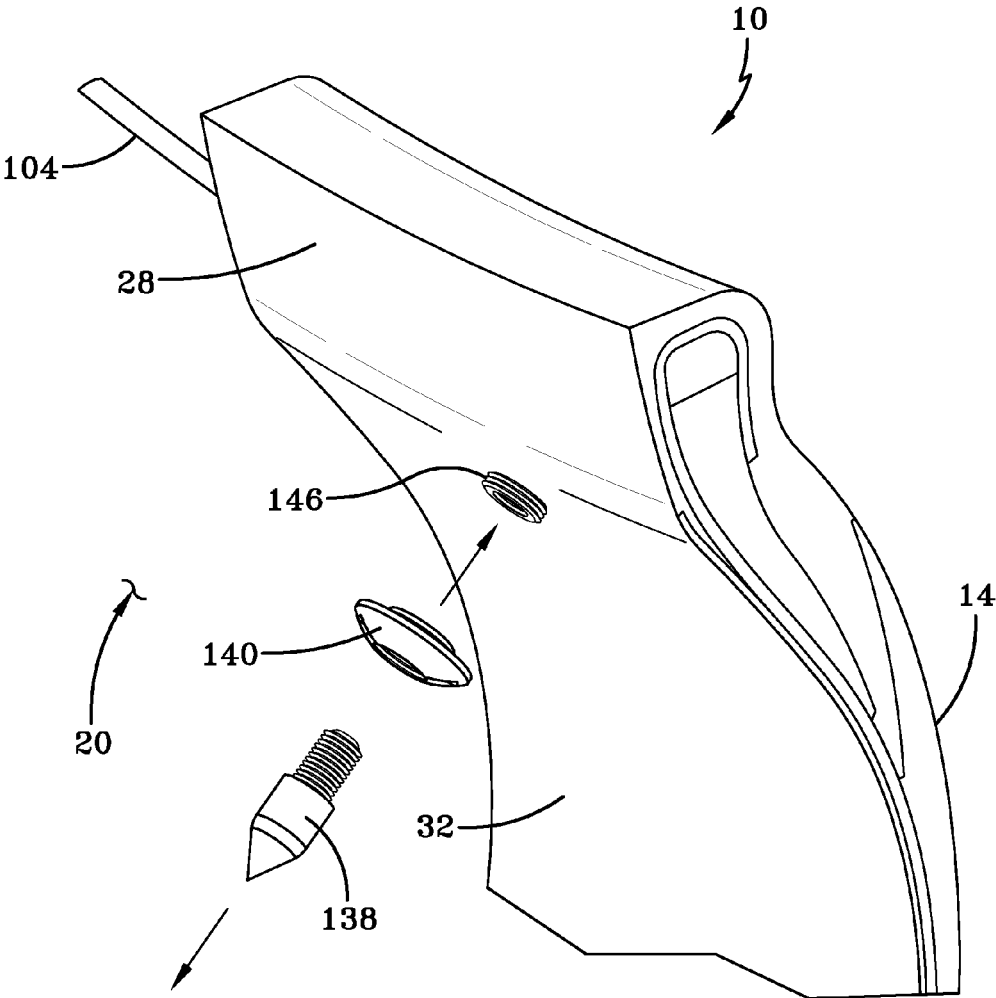

FIG-19D

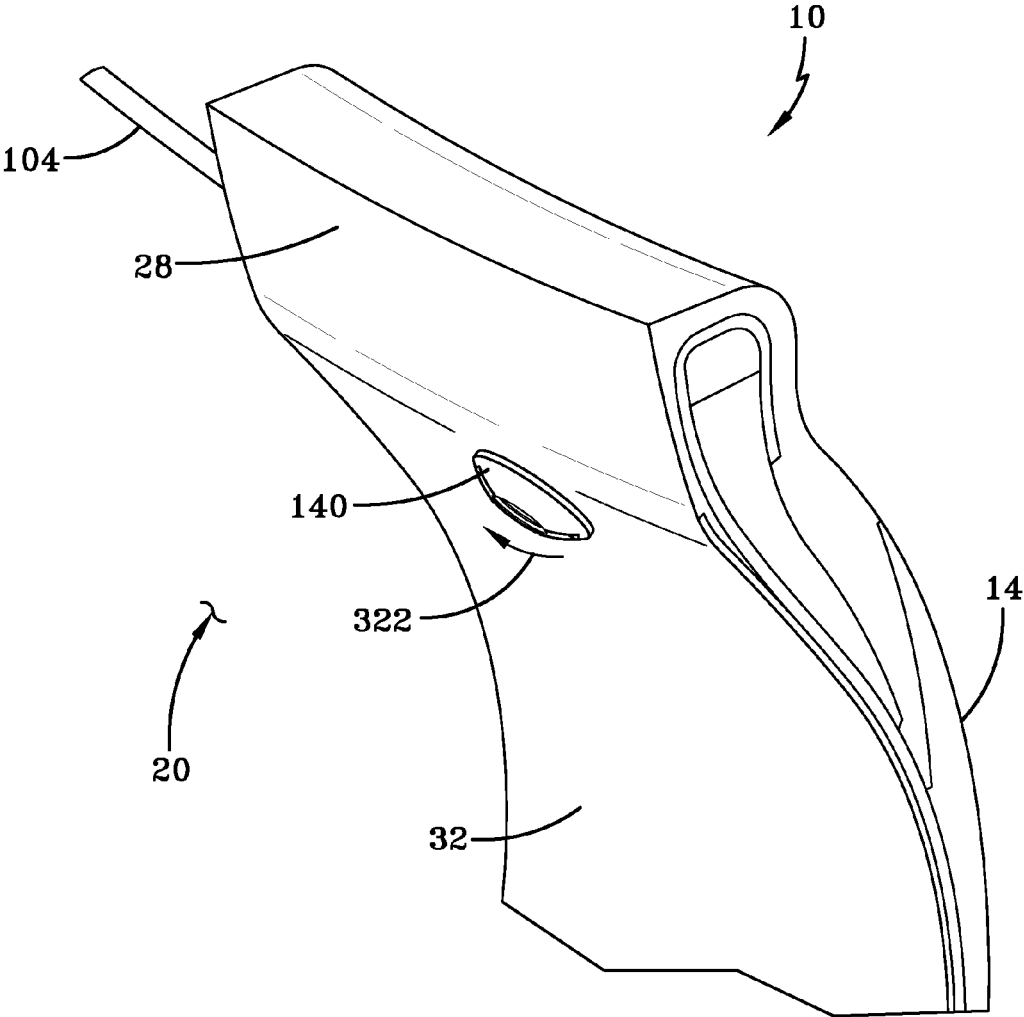

FIG-19E

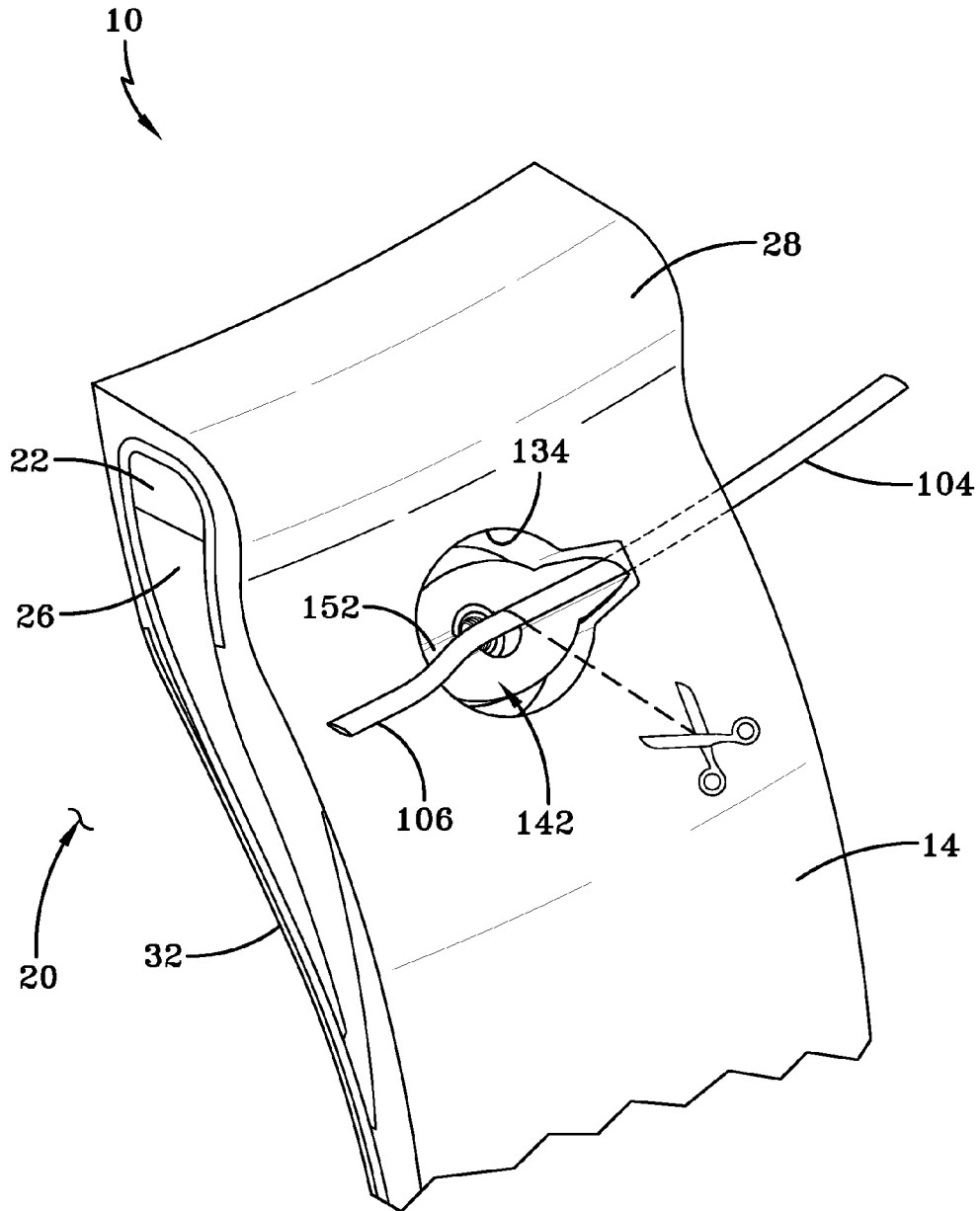

FIG-19F

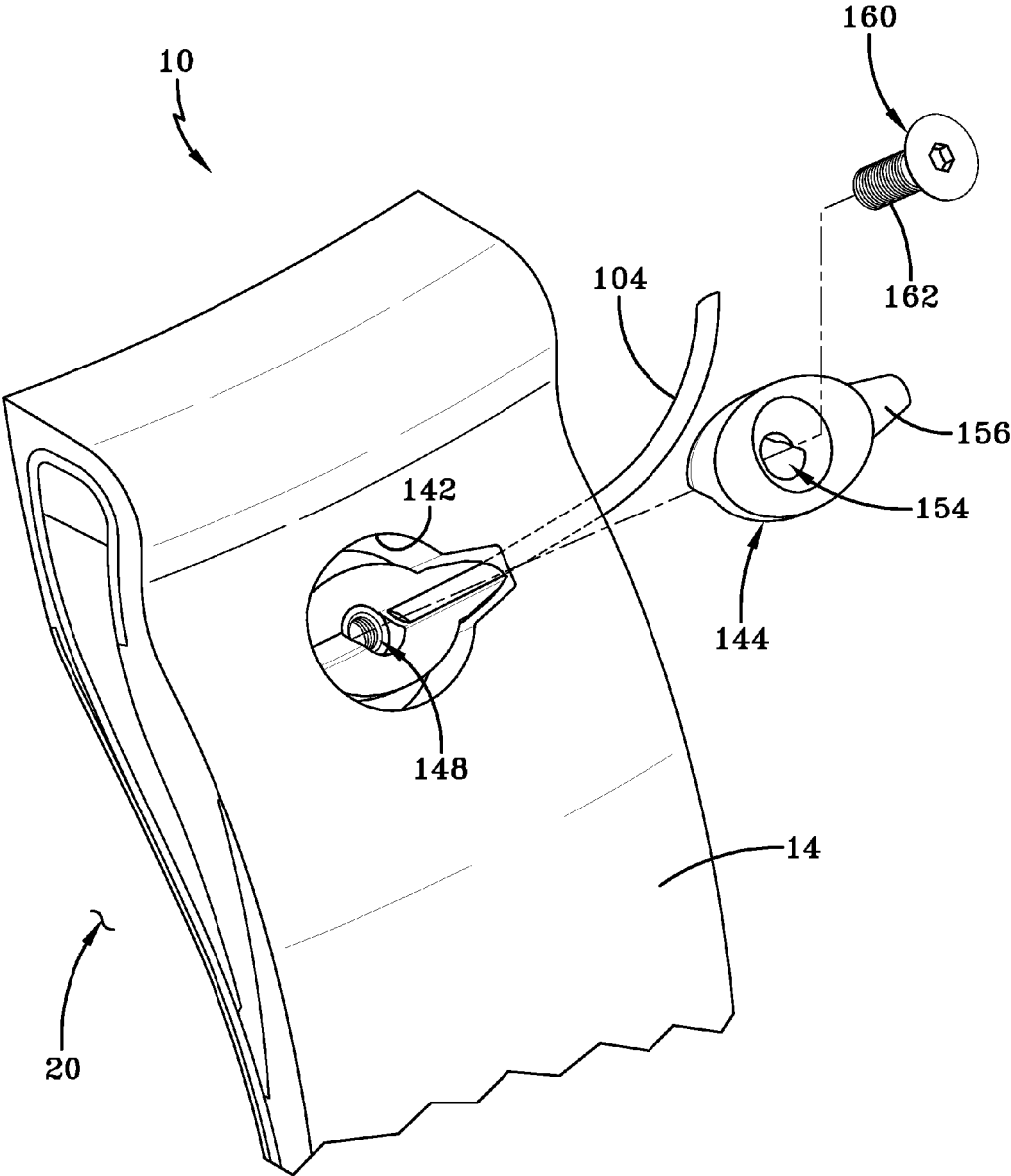

FIG-19G

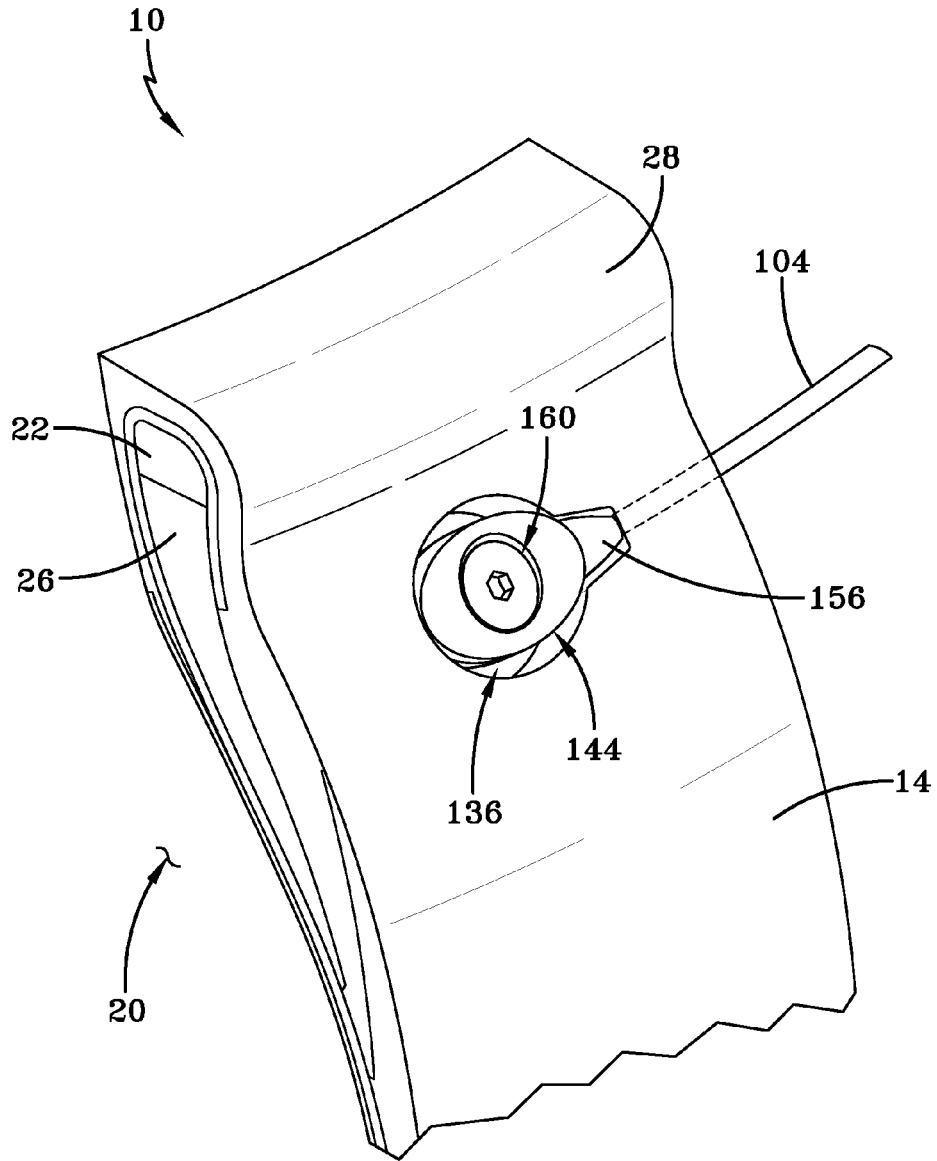

FIG-19H

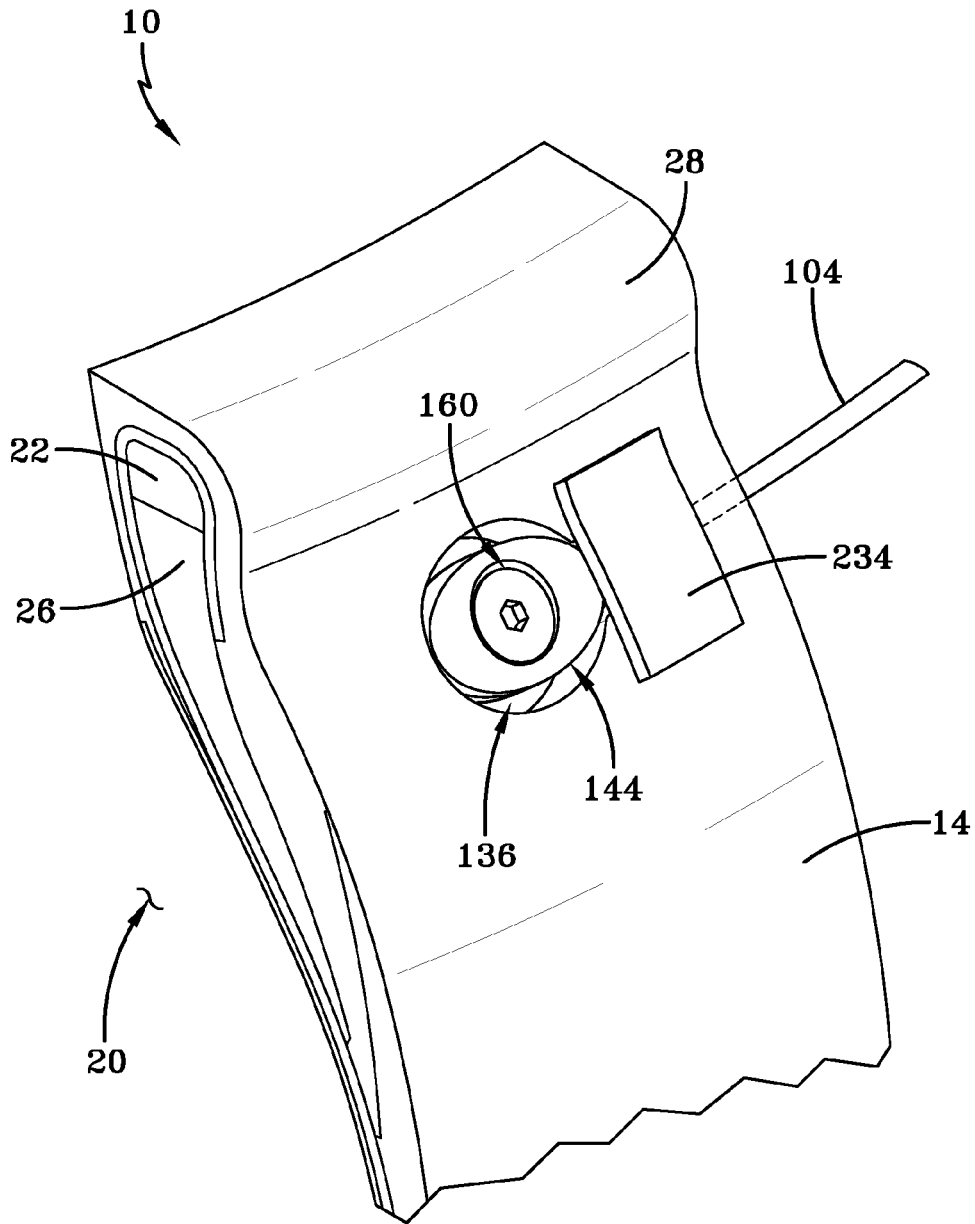

FIG-19I

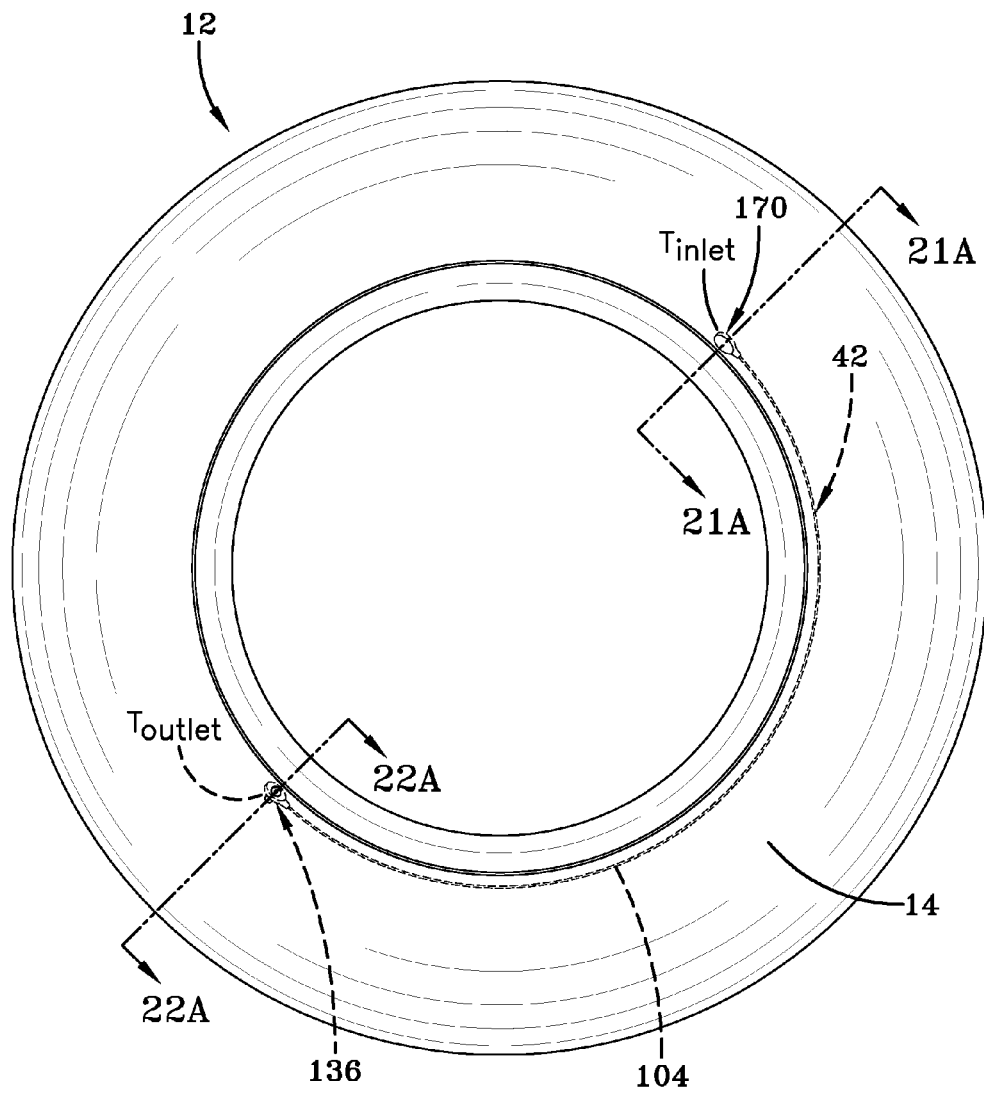

FIG-20

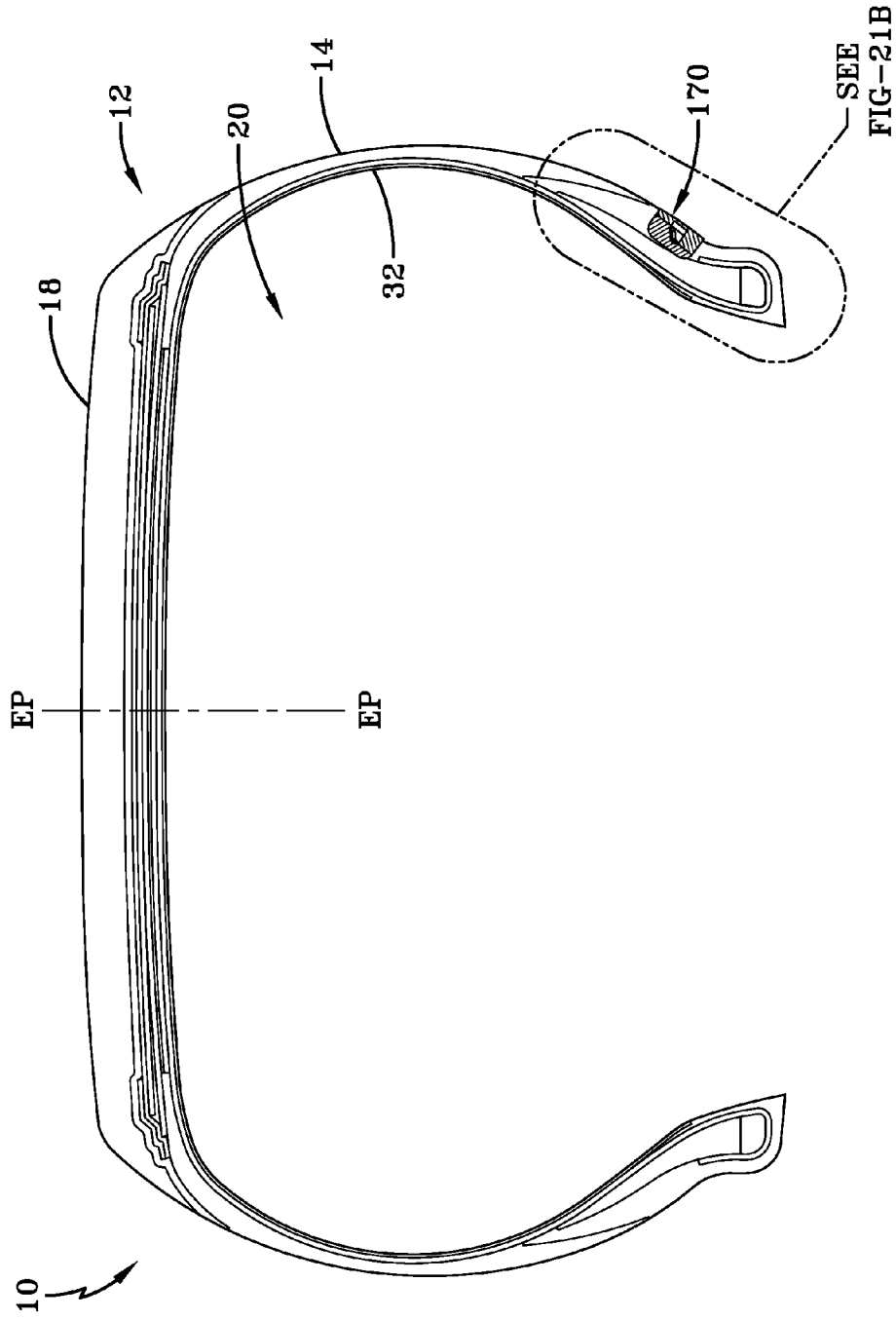

FIG-21A

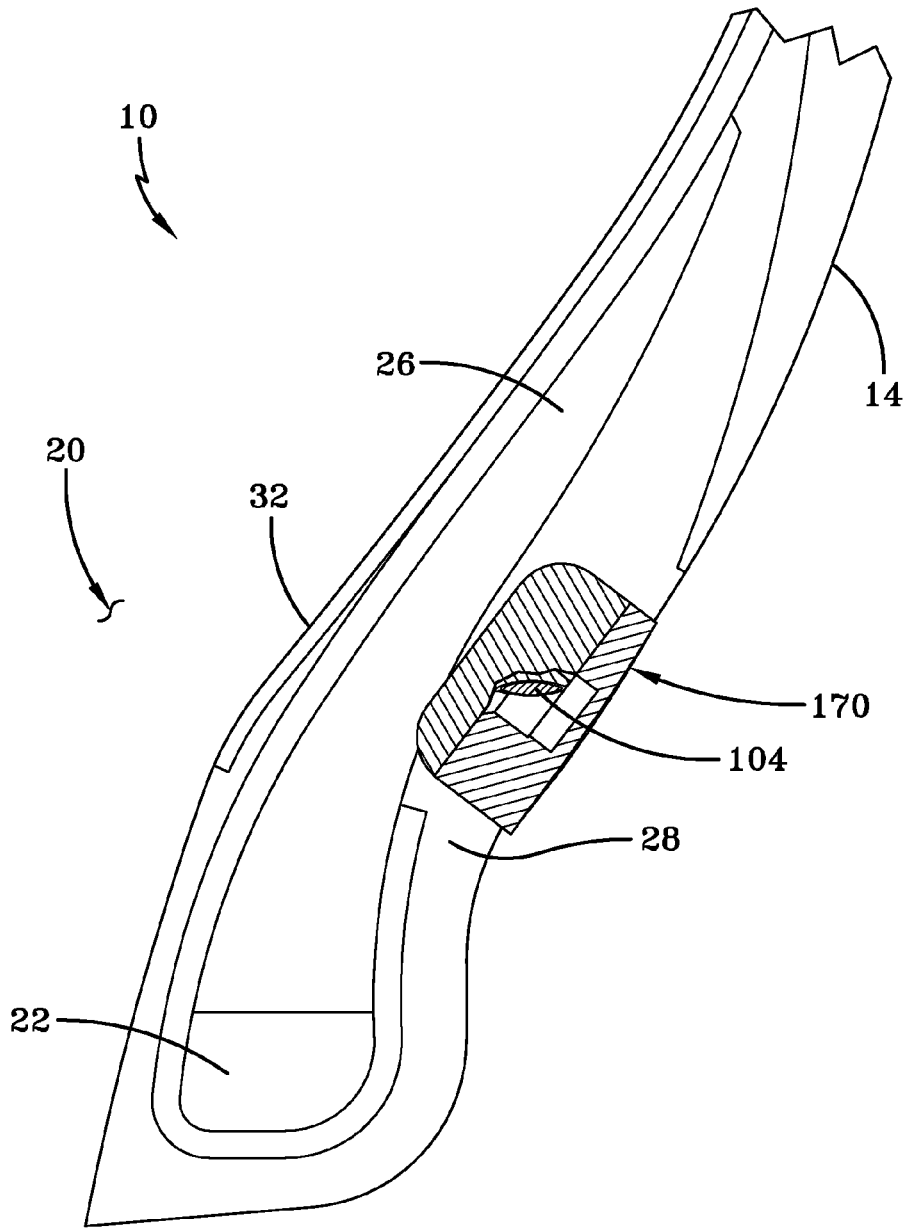

FIG-21B

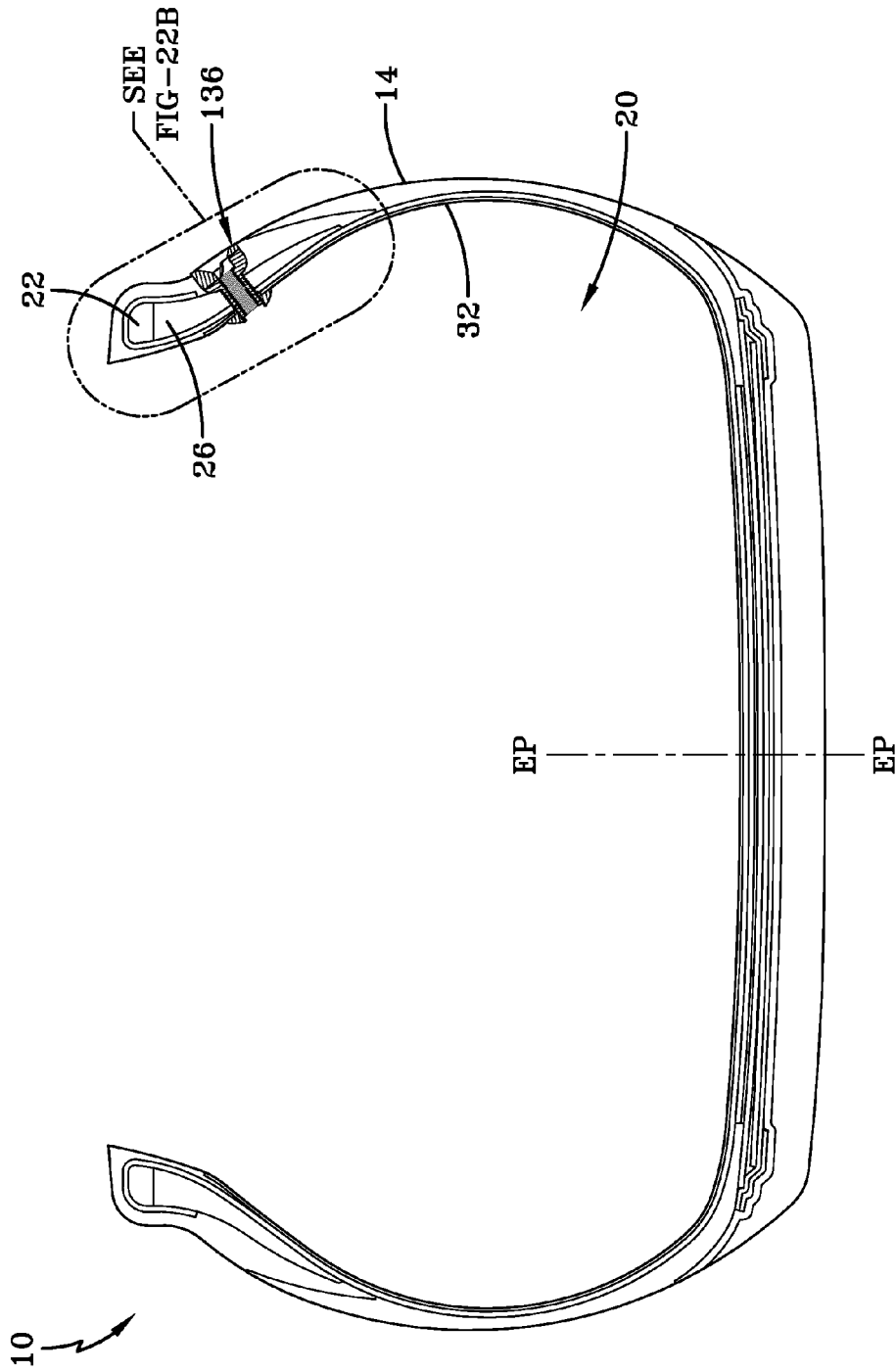

FIG-22A

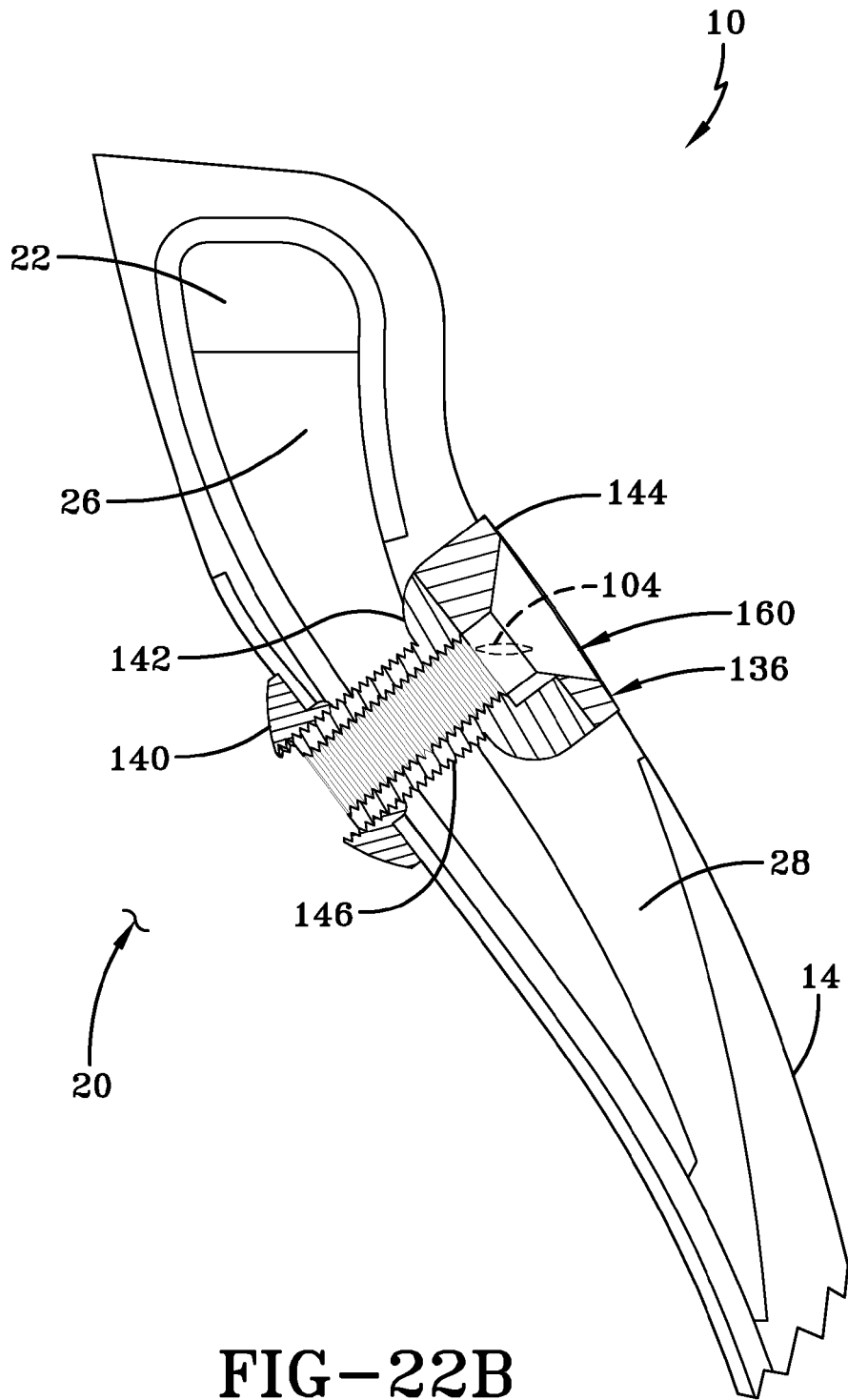

FIG-22B

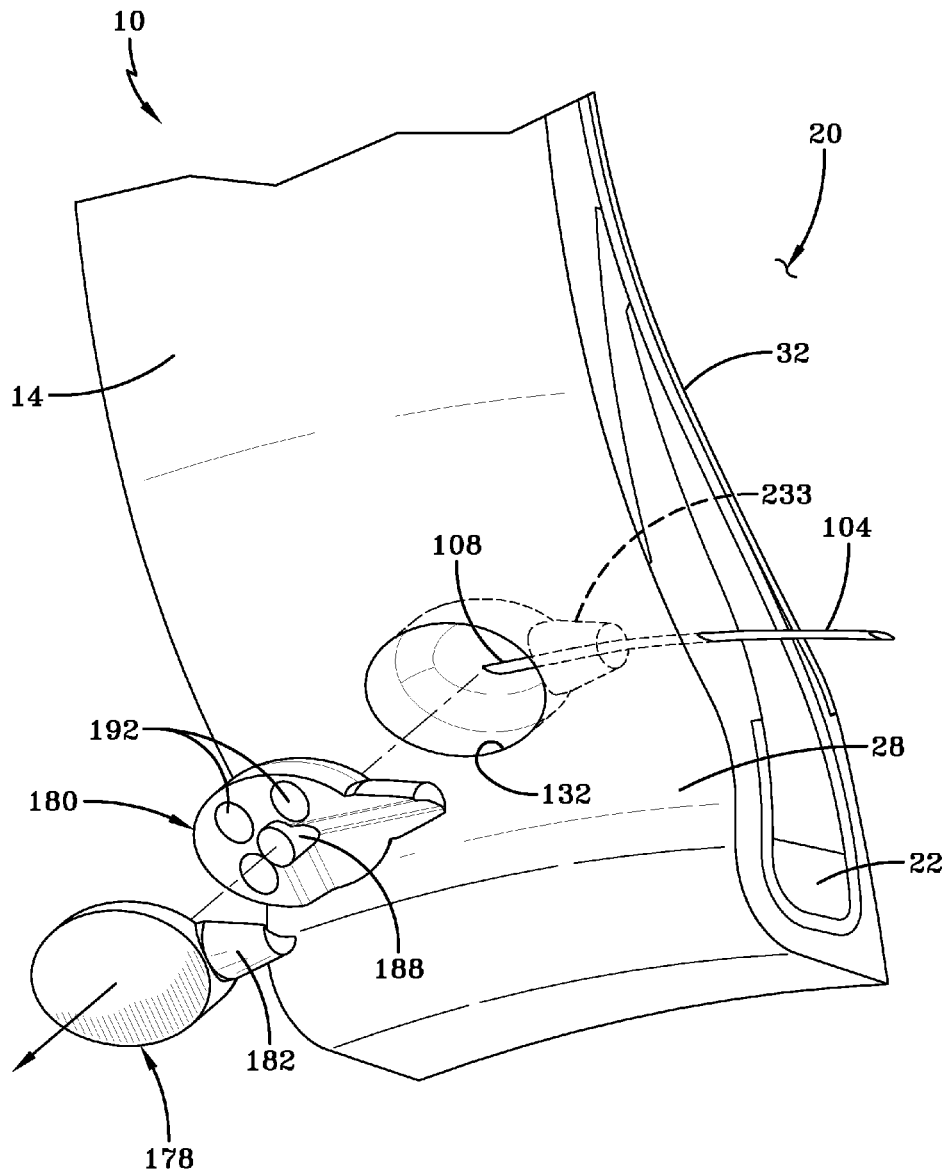

FIG-23

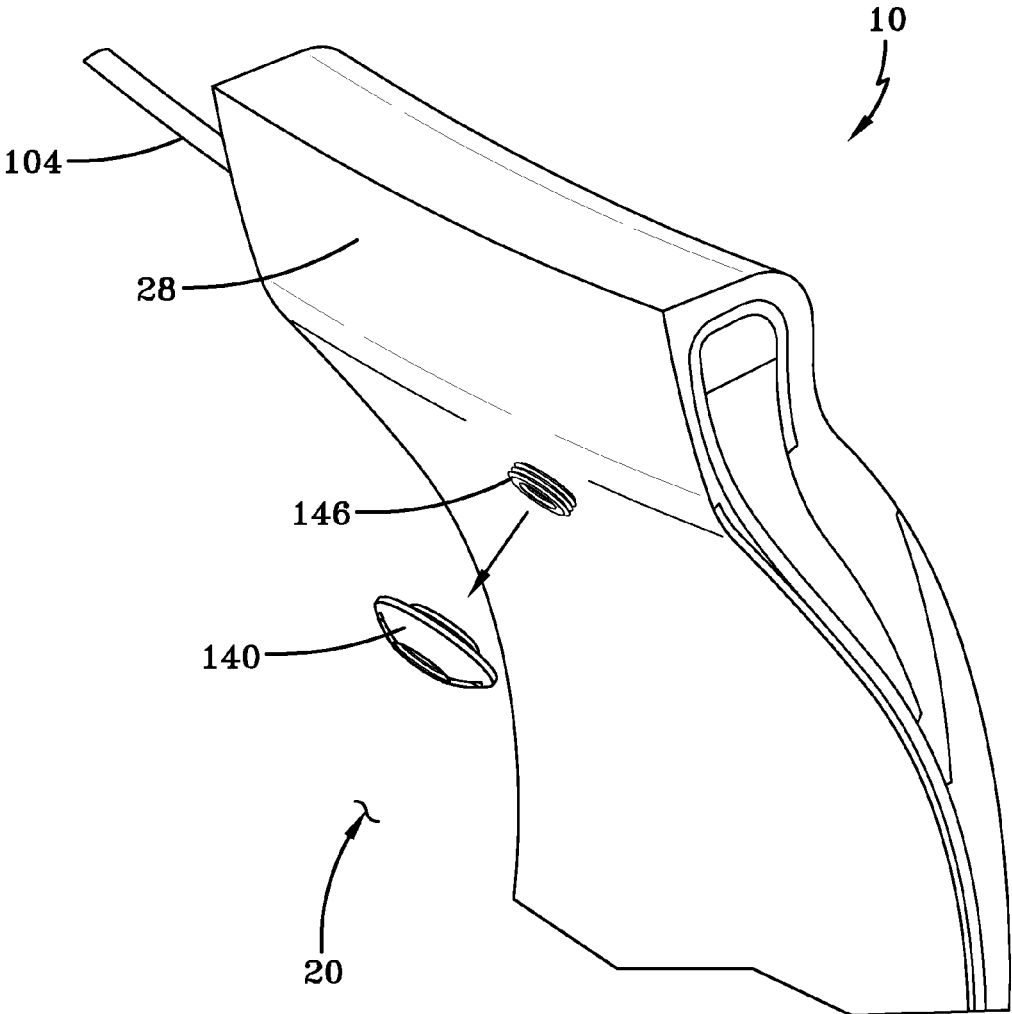

FIG-24

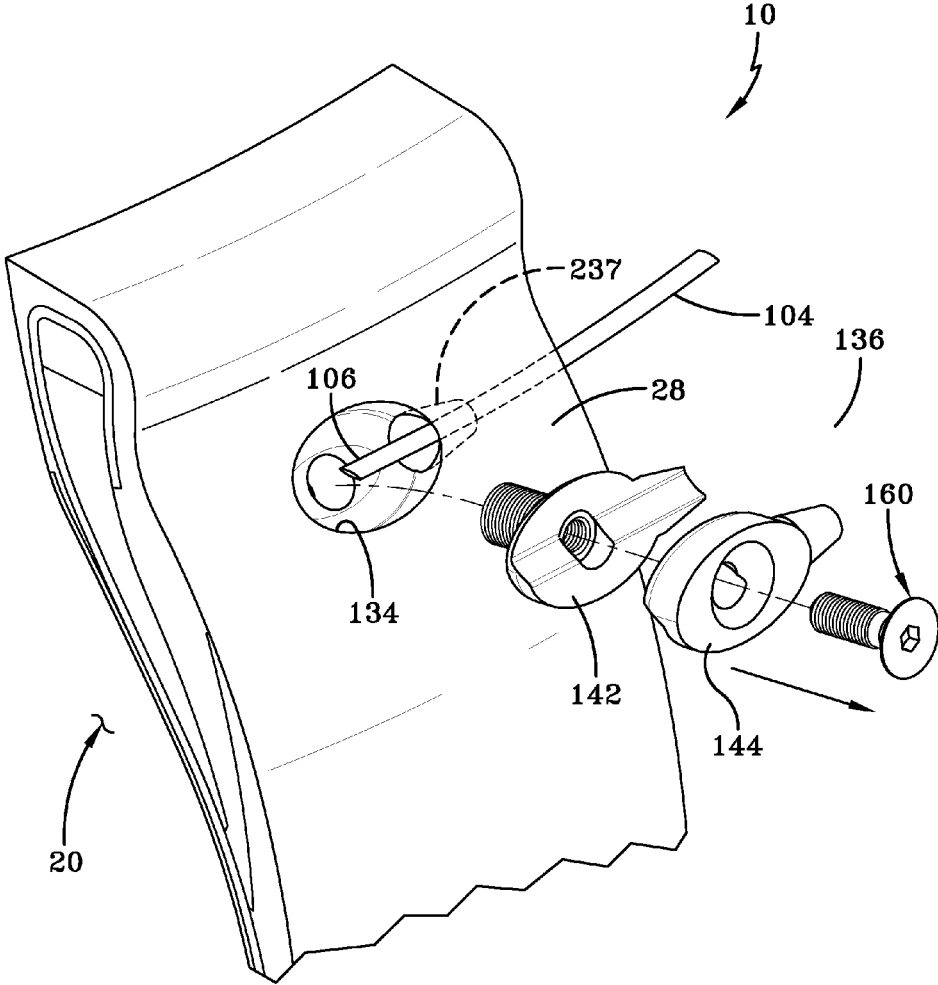

FIG-25

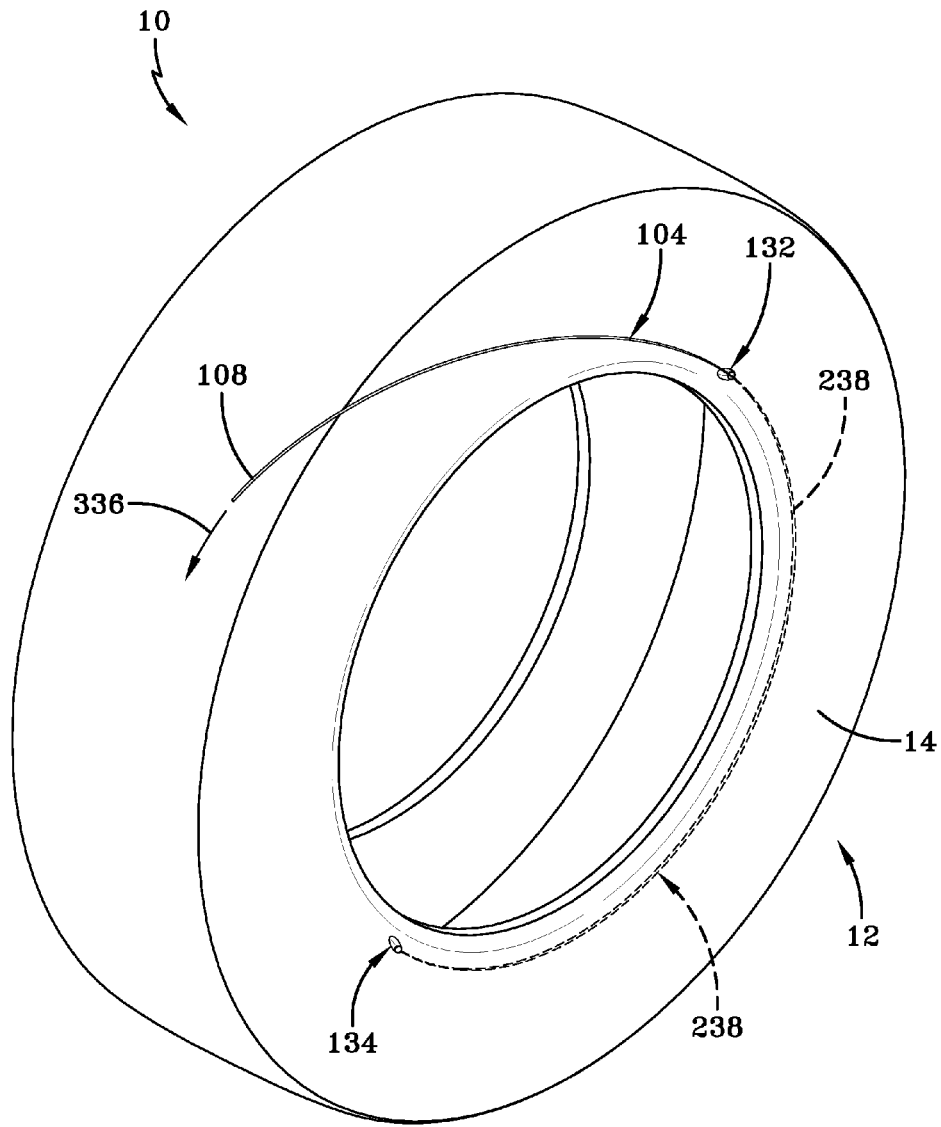

FIG-26

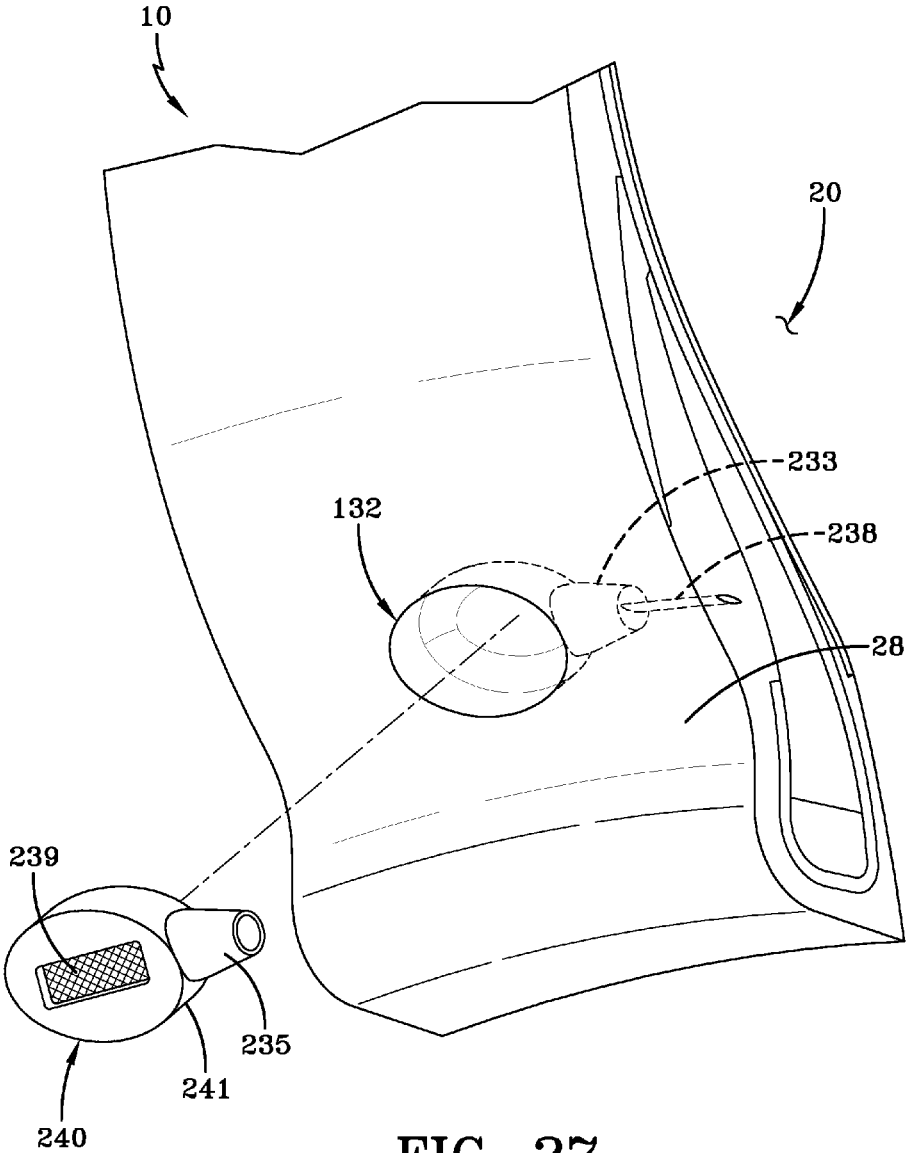

FIG-27

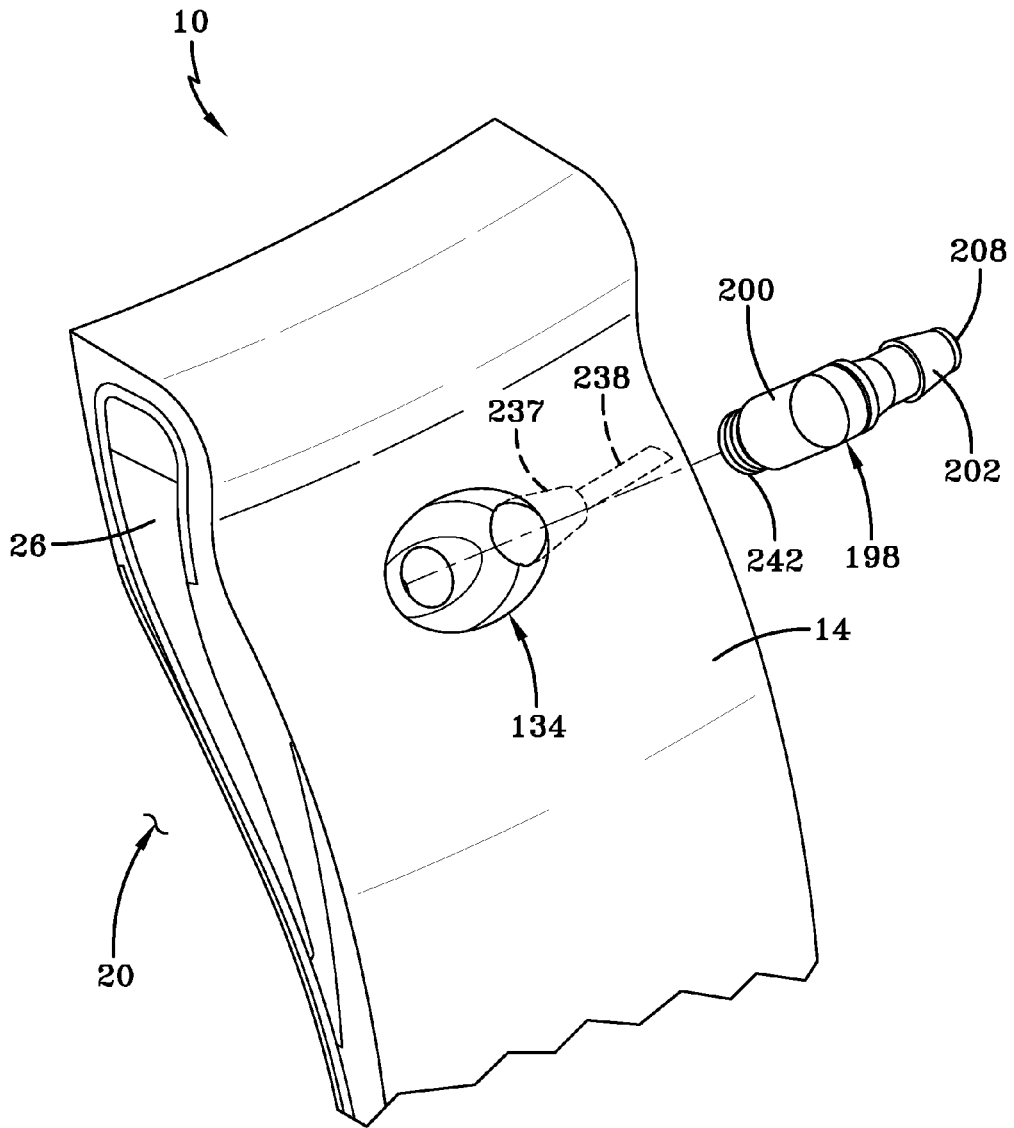

FIG-28A

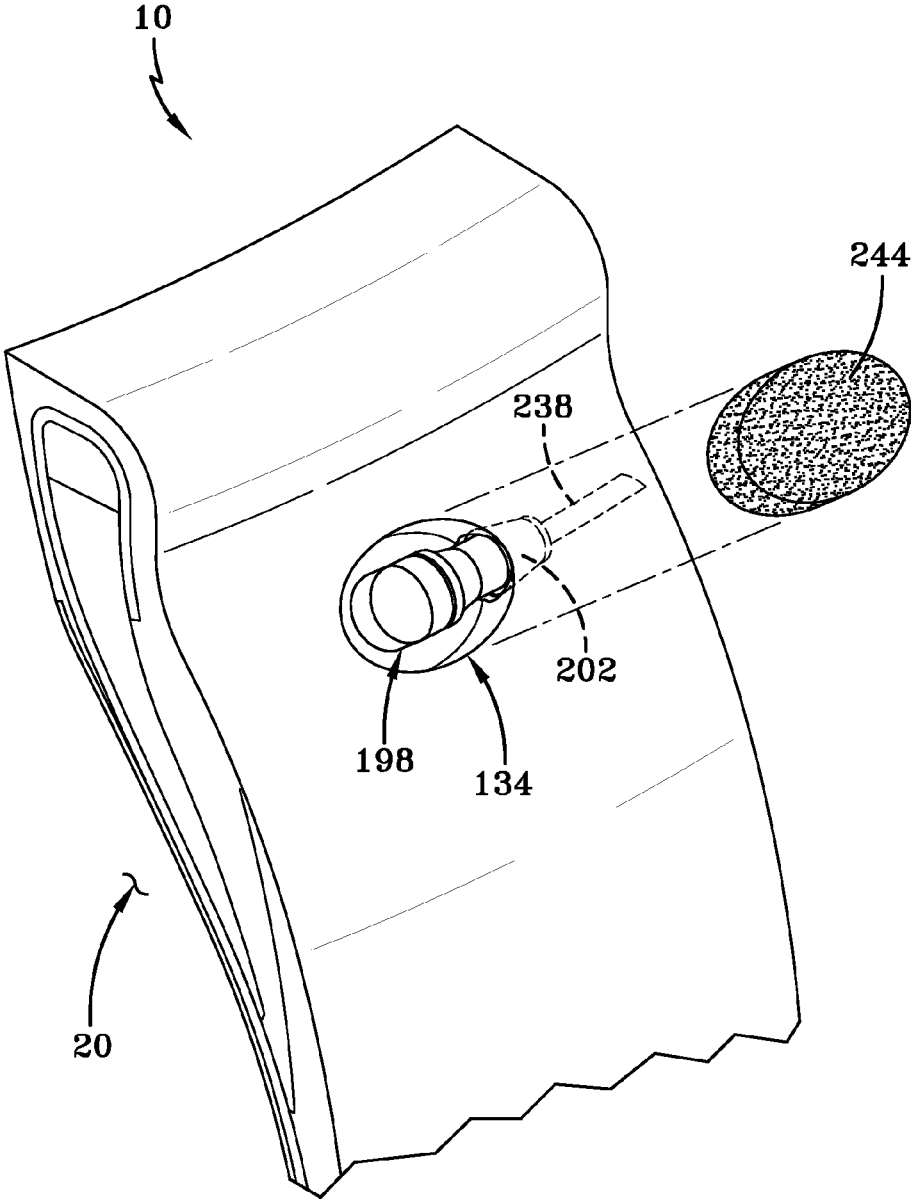

FIG-28B

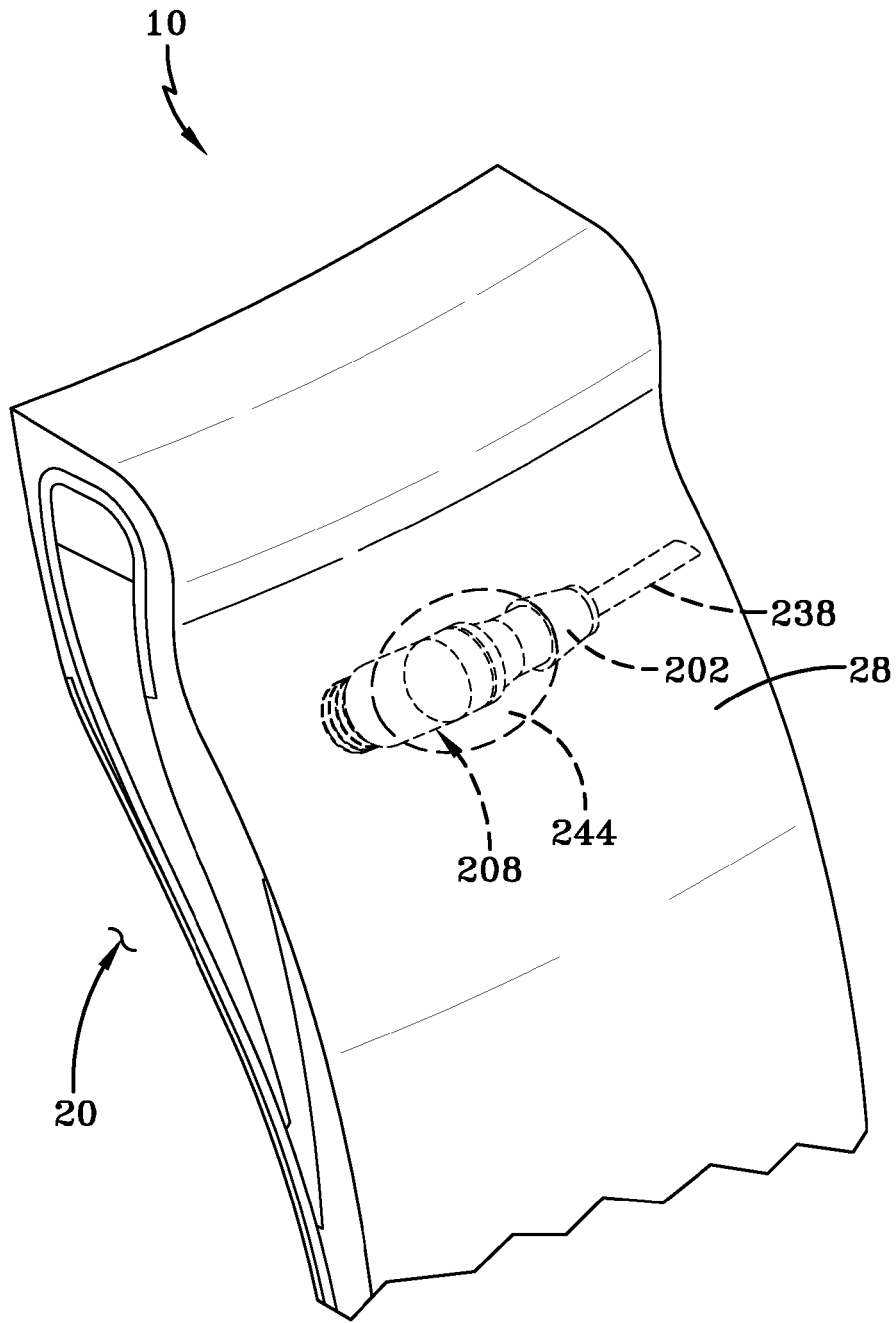

FIG-28C

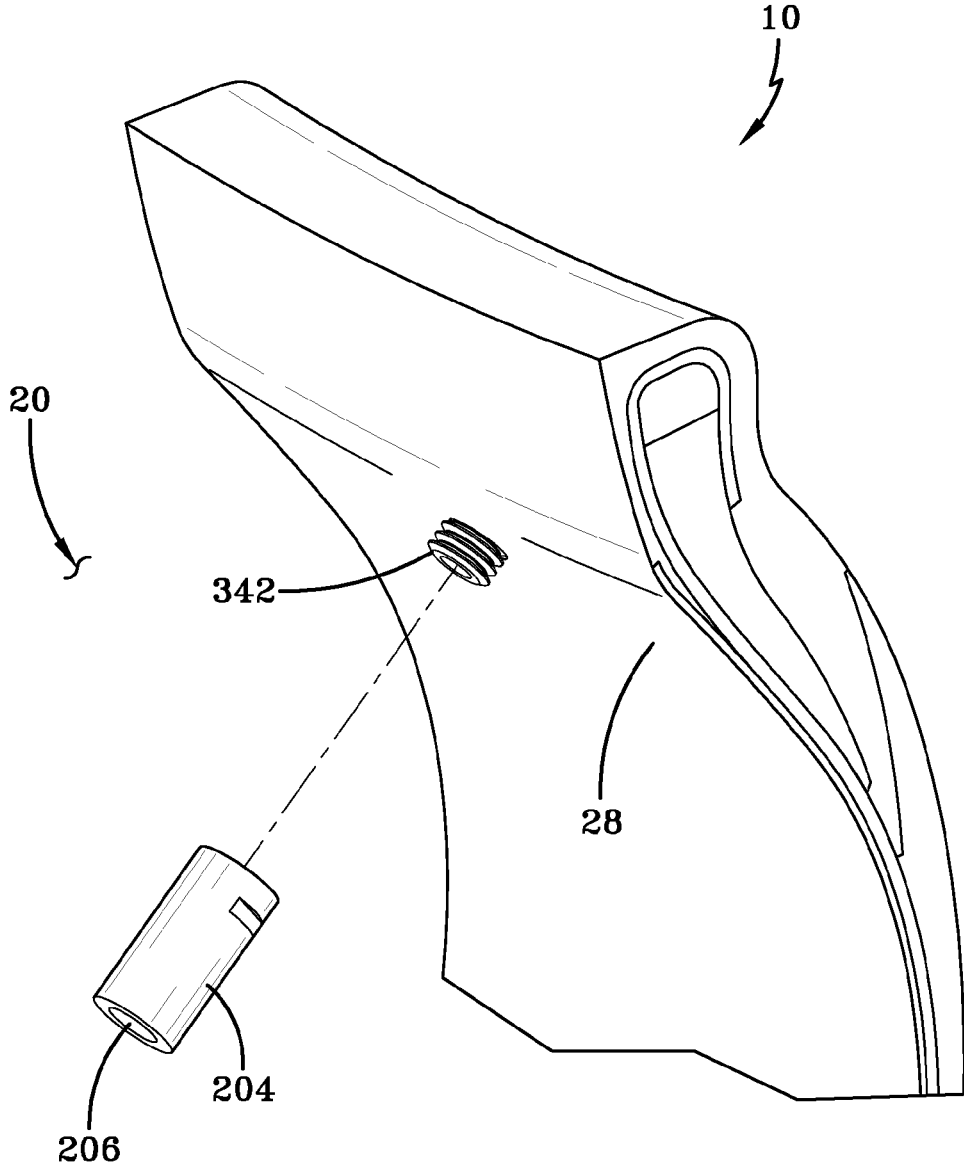

FIG-29A

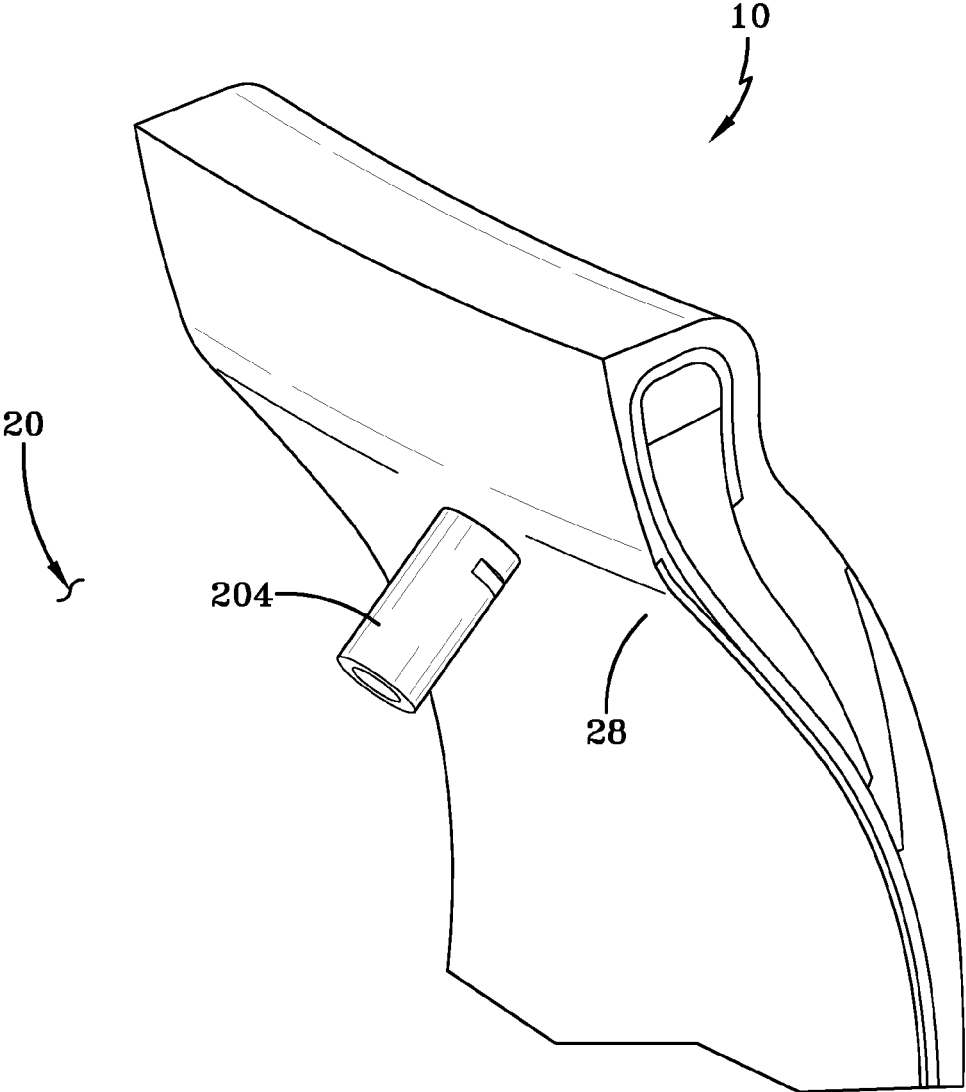

FIG-29B

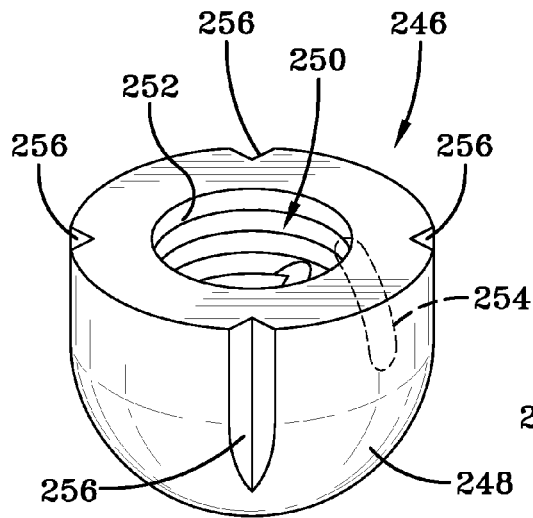

FIG-30A

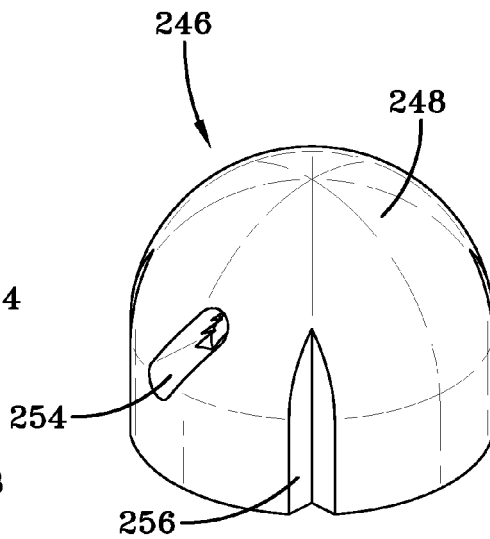

FIG-30B

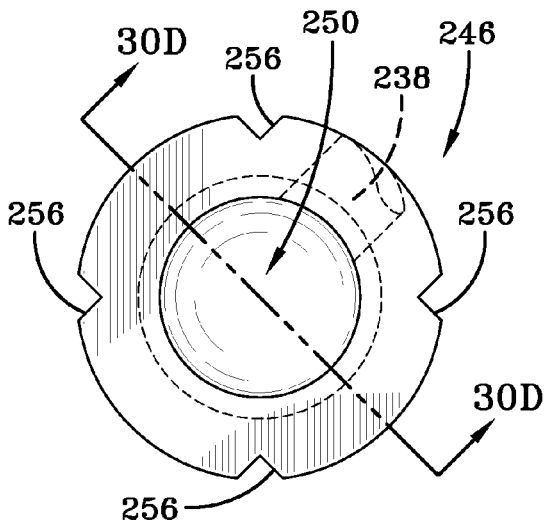

FIG-30C

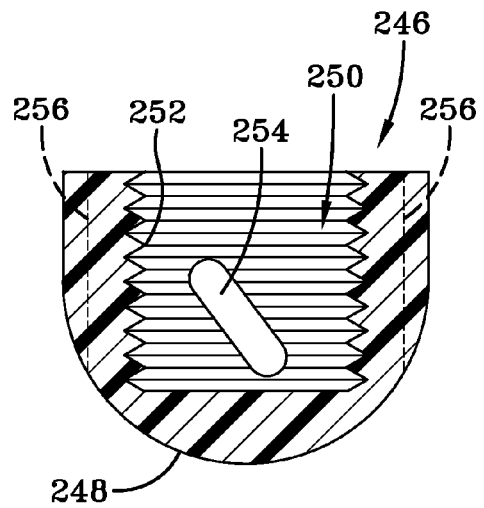

FIG-30D

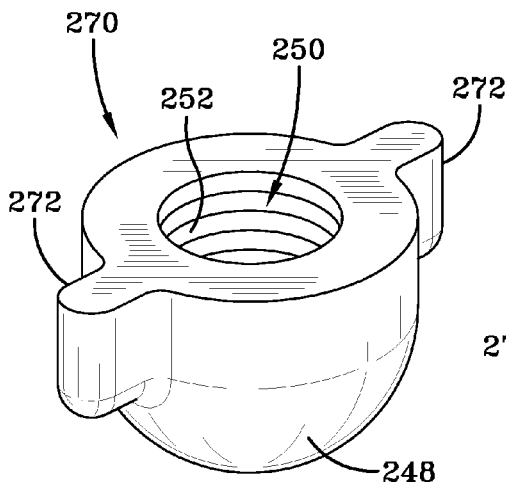

FIG-30E

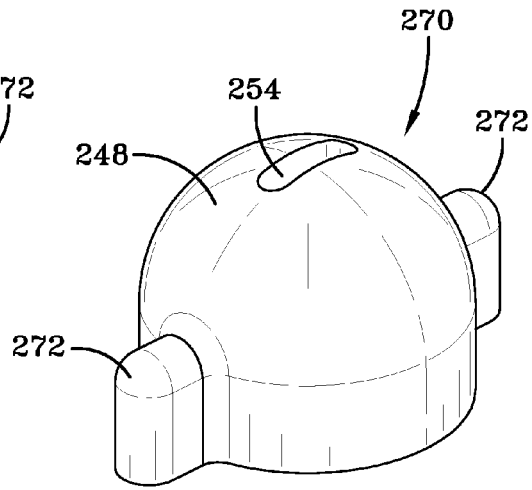

FIG-30F

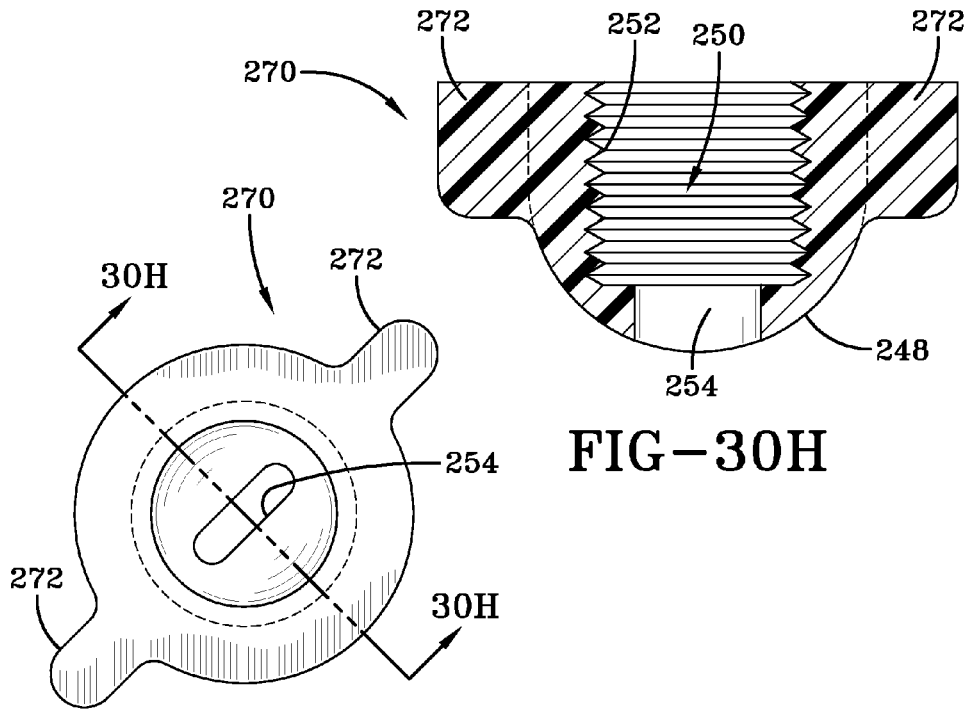

FIG-30G

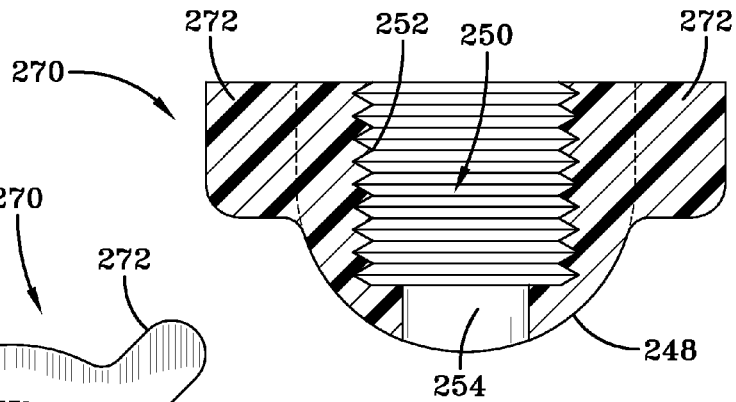

FIG-30H

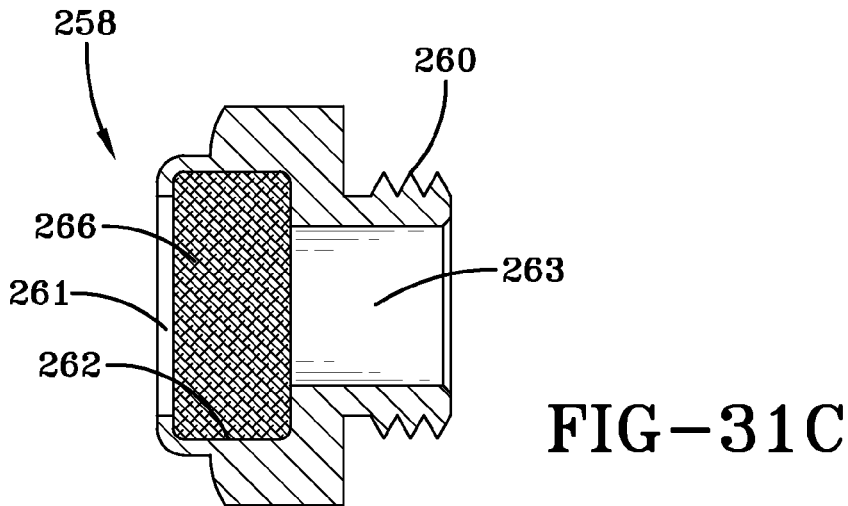
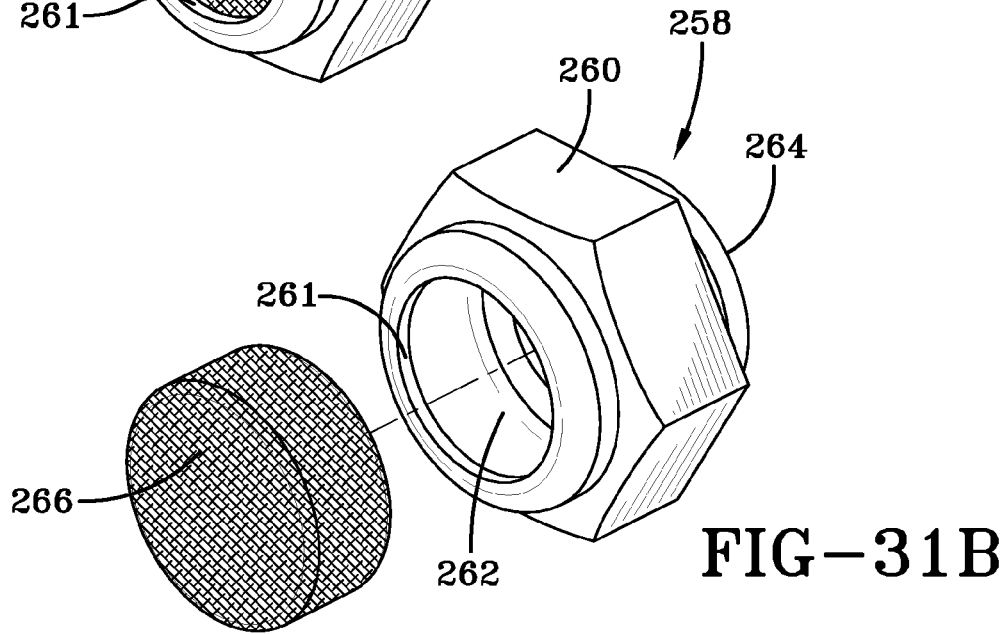
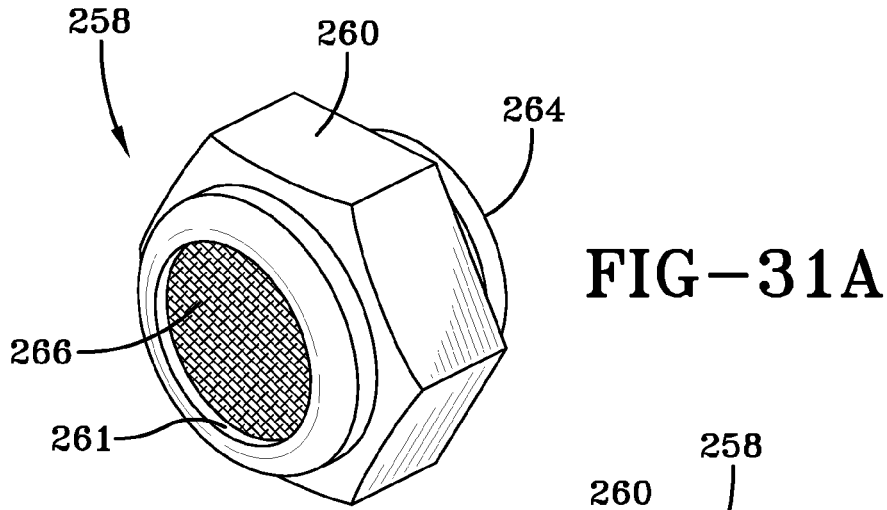

FIG-31C

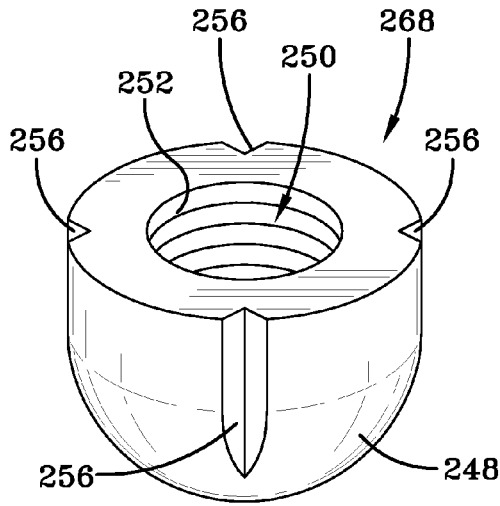

FIG-32A

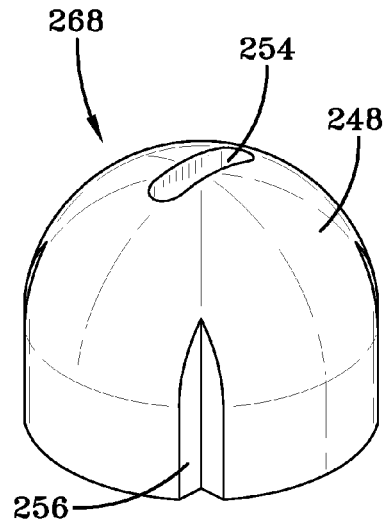

FIG-32B

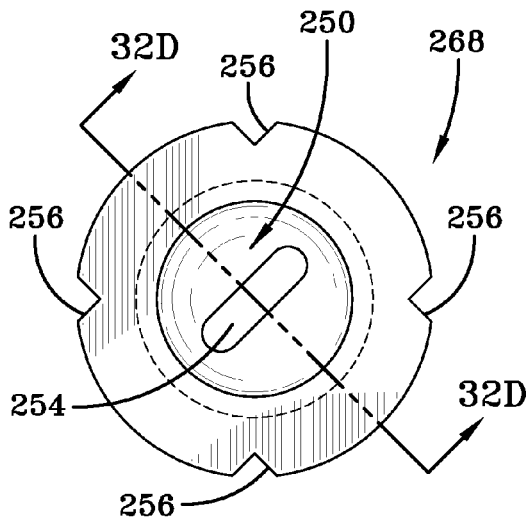

FIG-32C

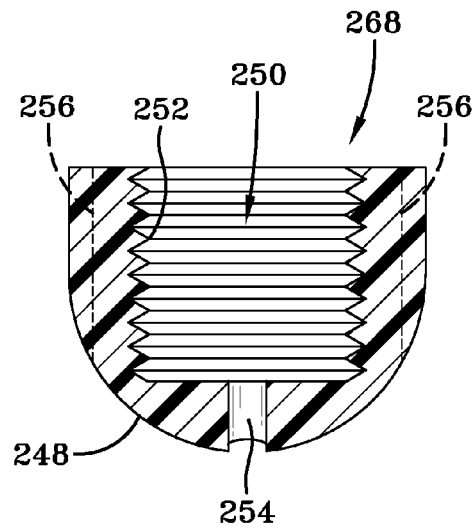

FIG-32D

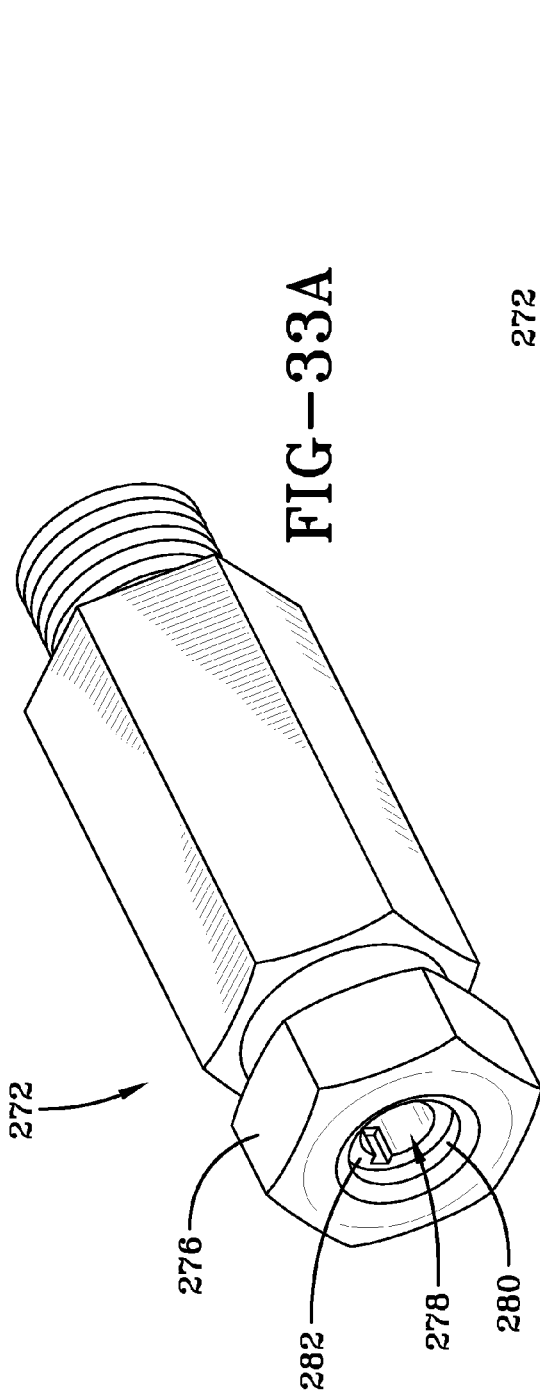

FIG-33A

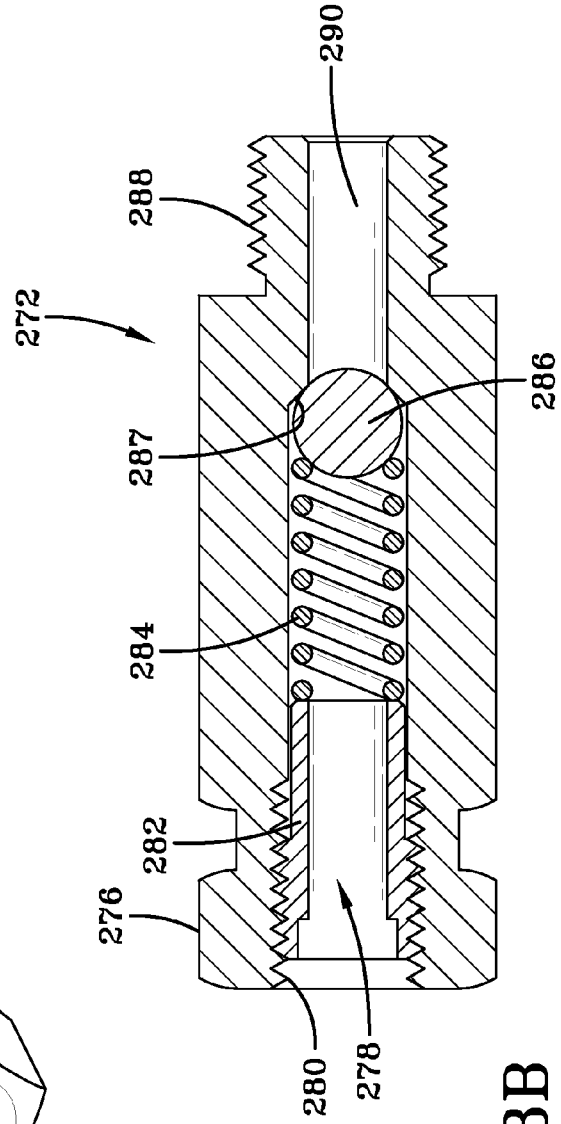

FIG-33B

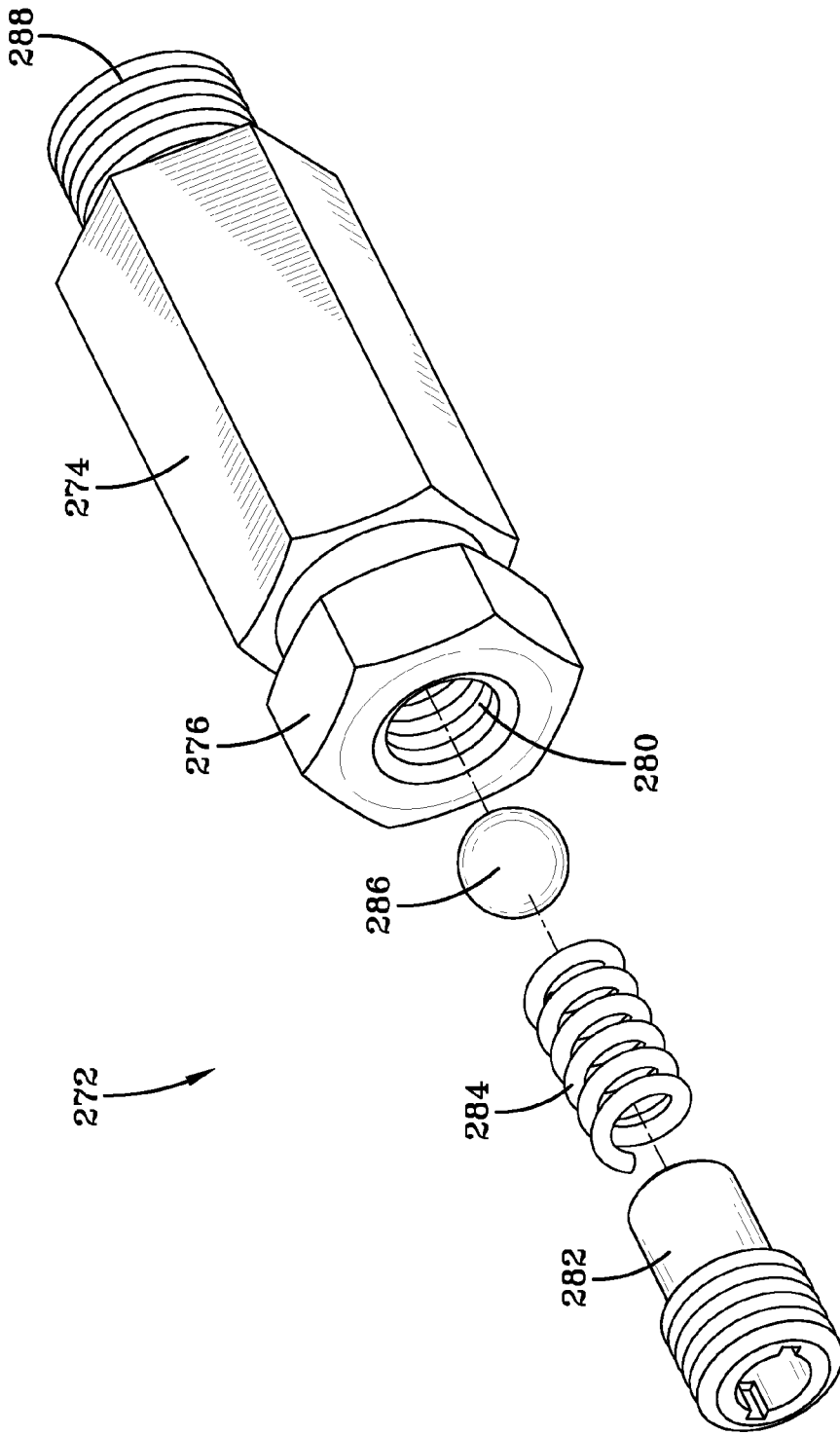

FIG-33C

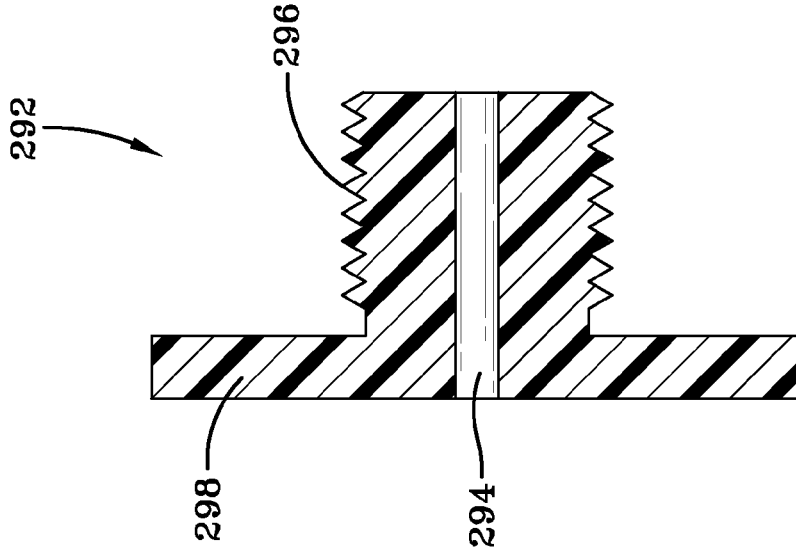

FIG-34B

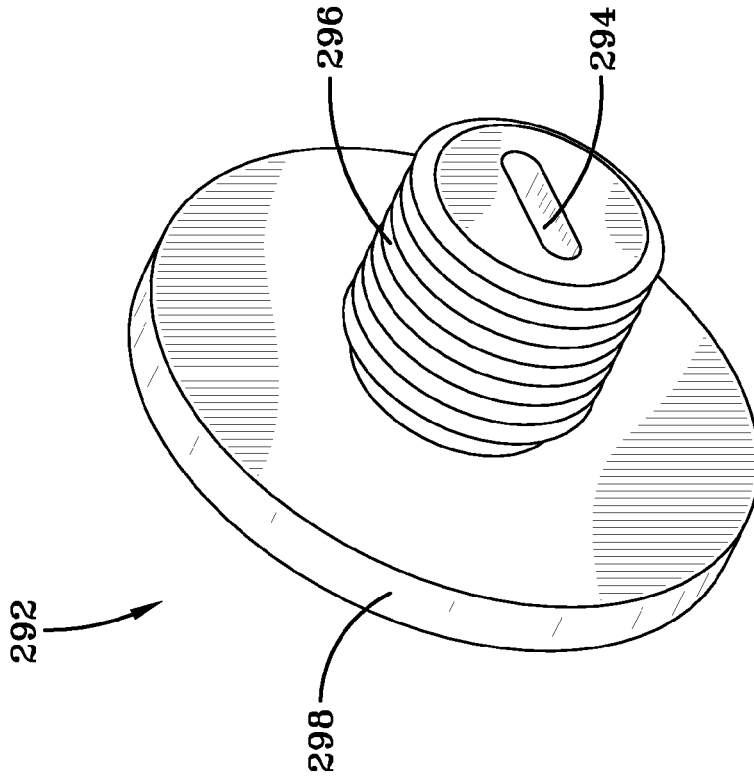

FIG-34A

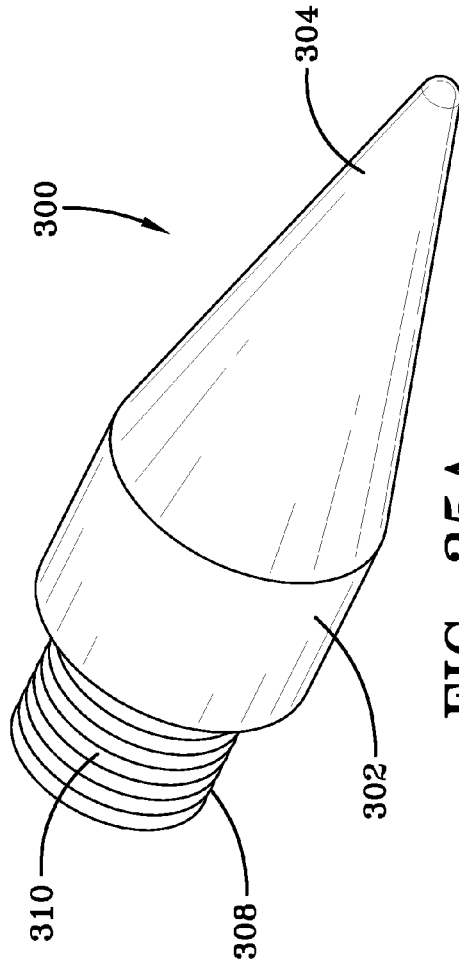

FIG-35A

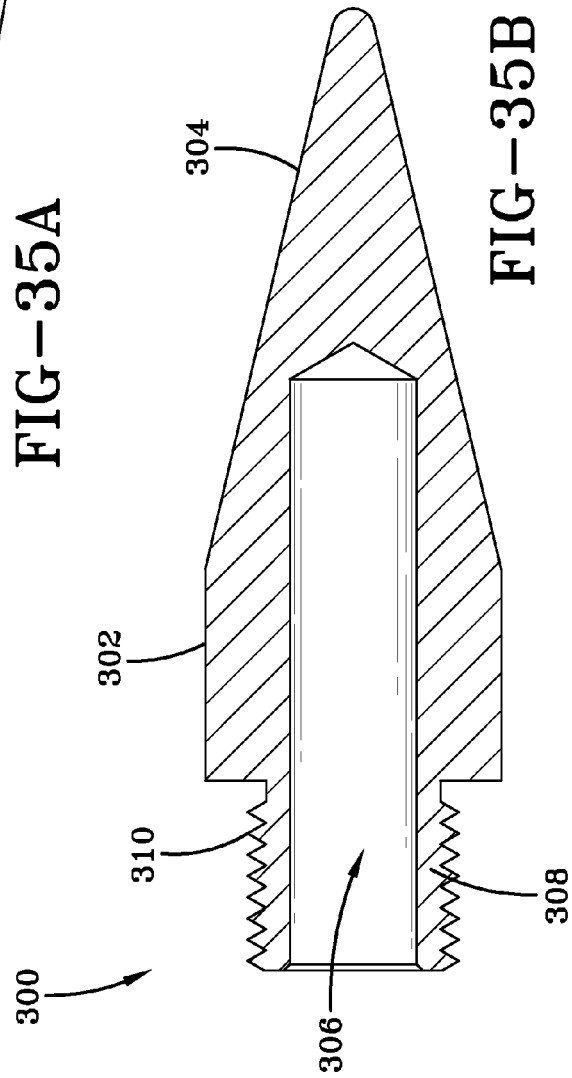

FIG-35B

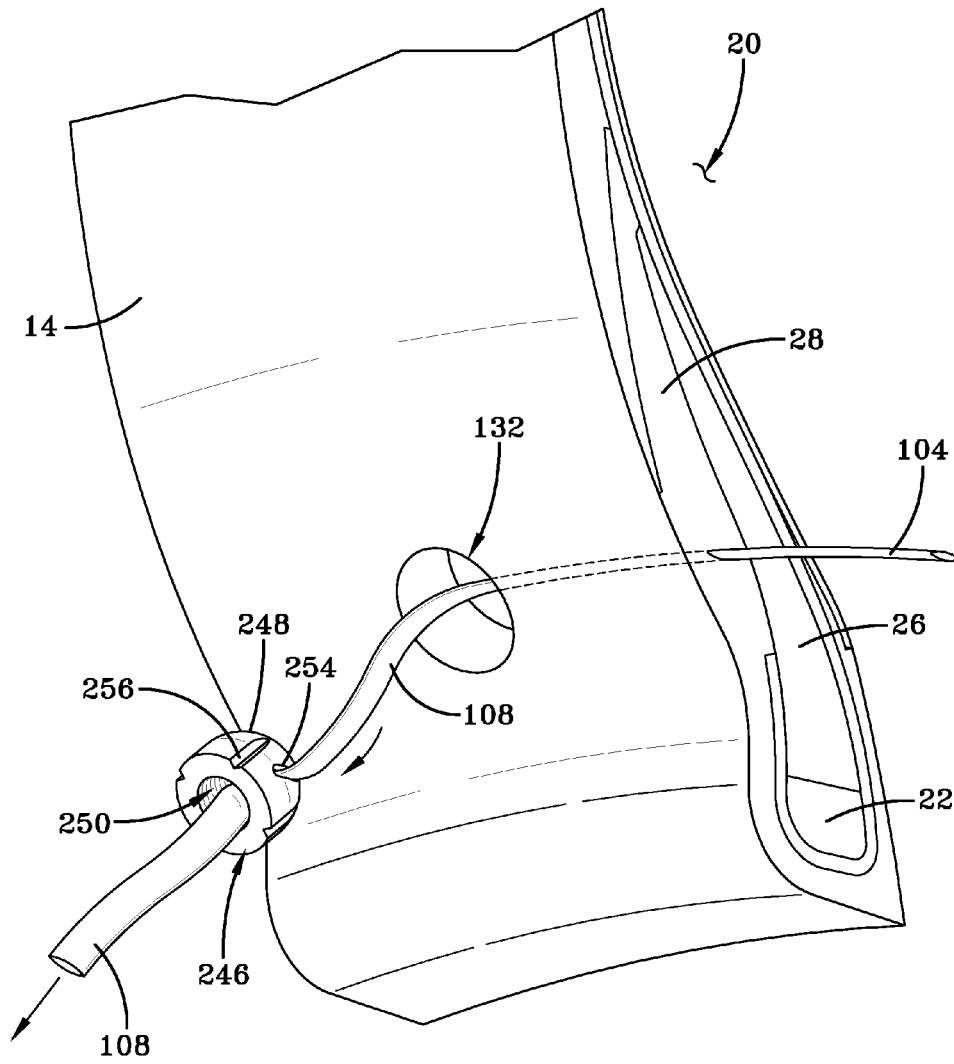

FIG-36A

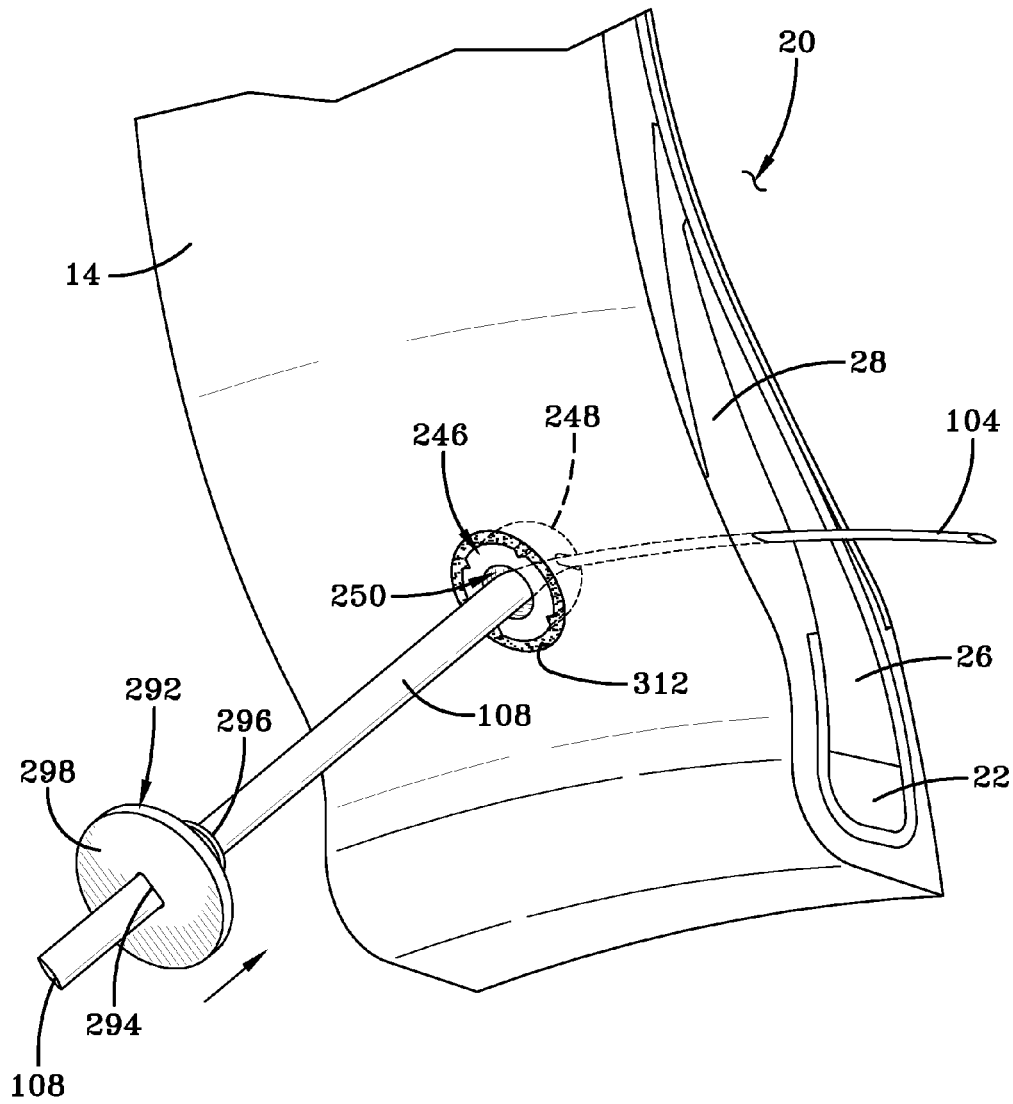

FIG-36B

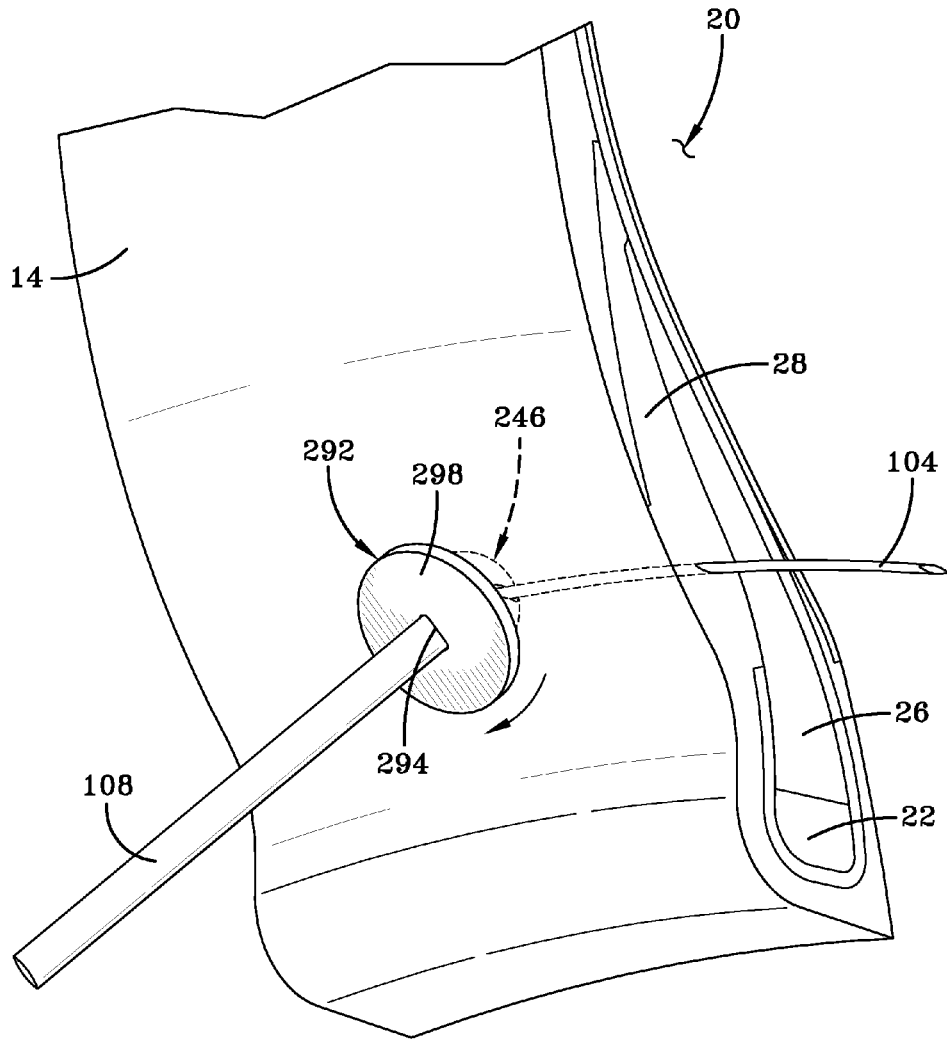

FIG-36C

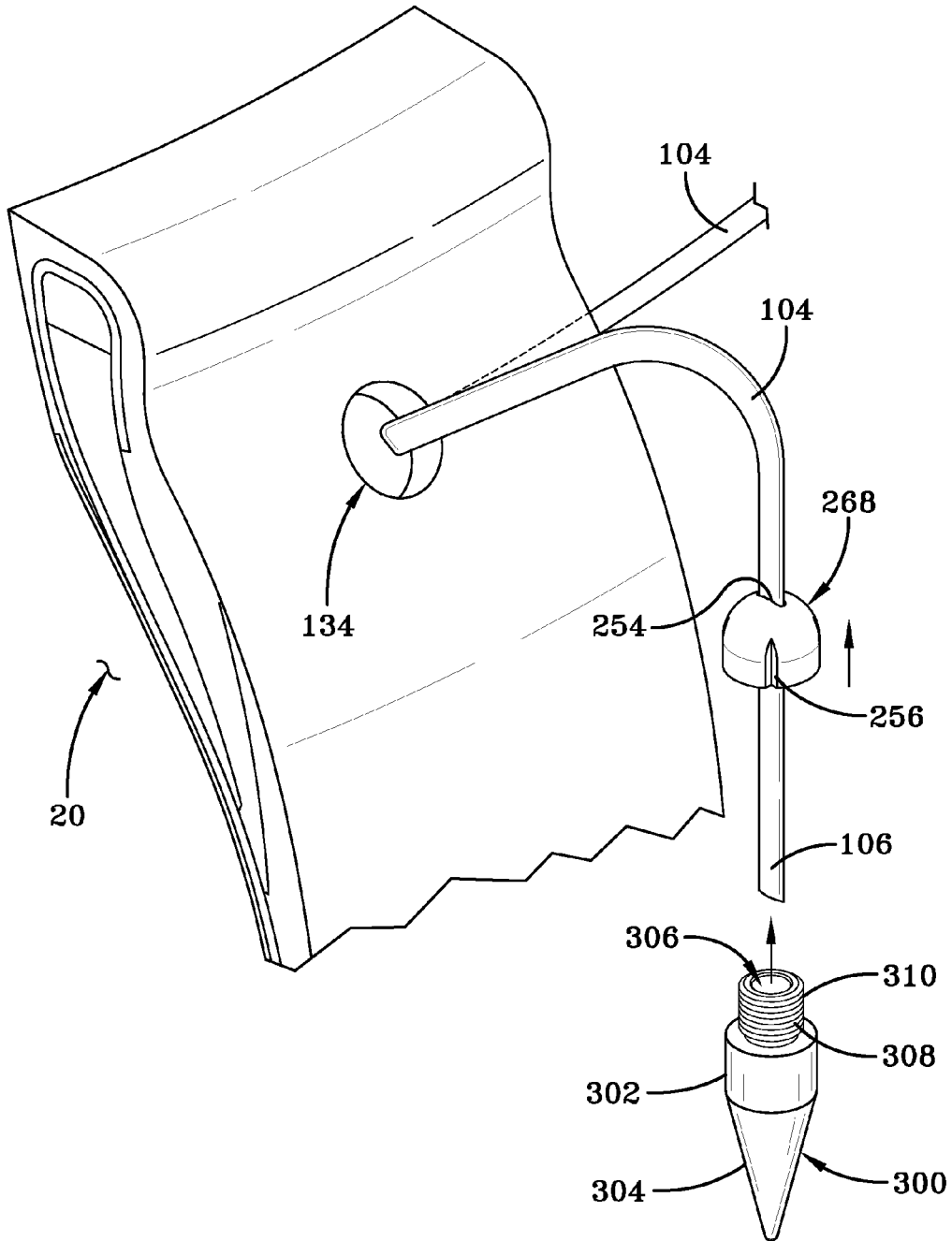

FIG-37A

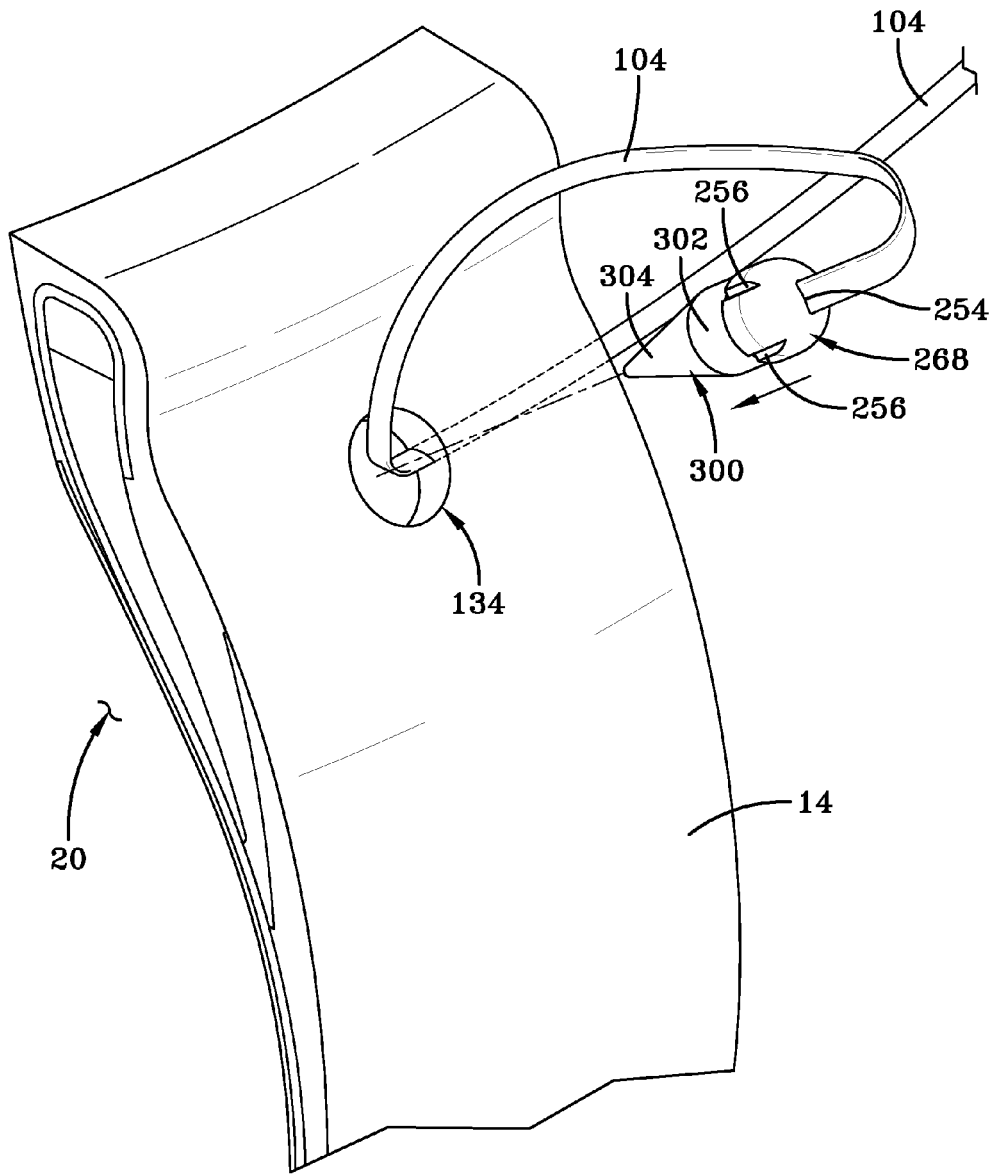

FIG-37B

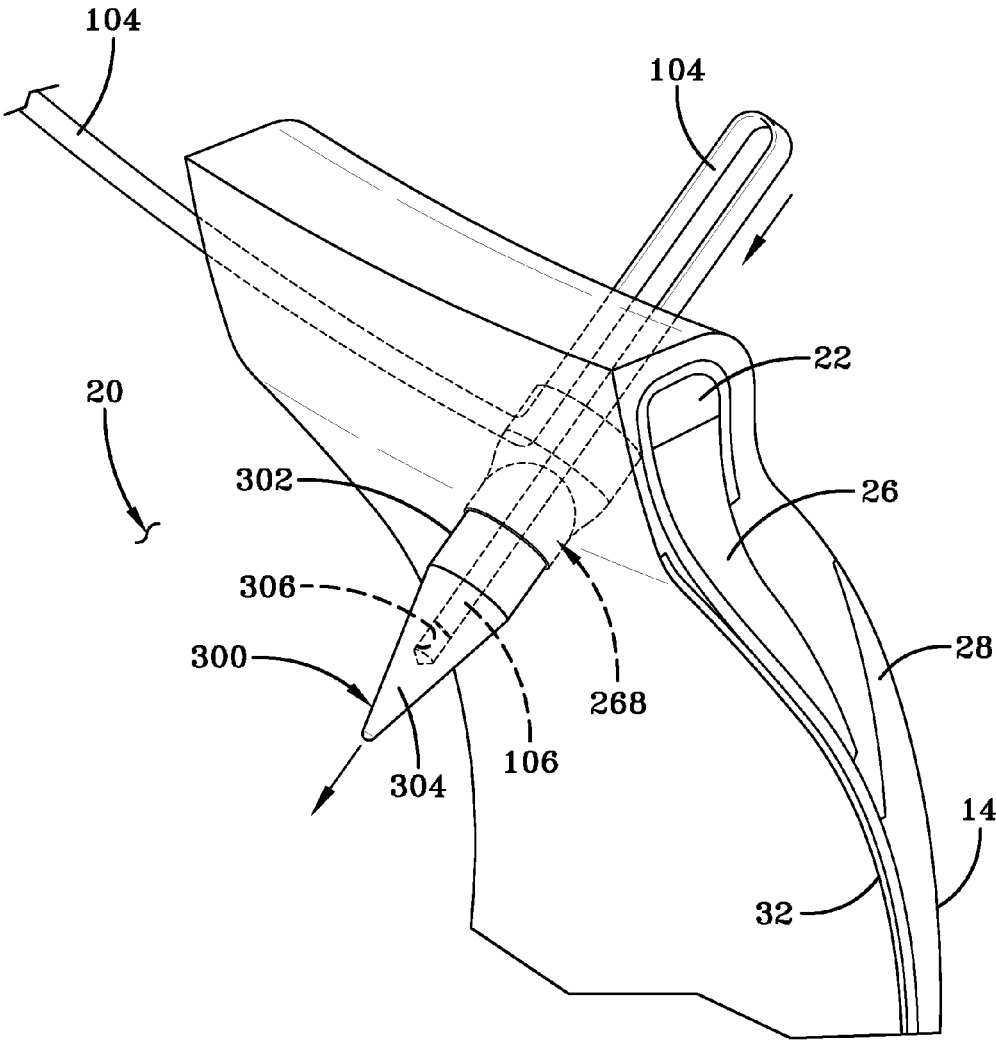
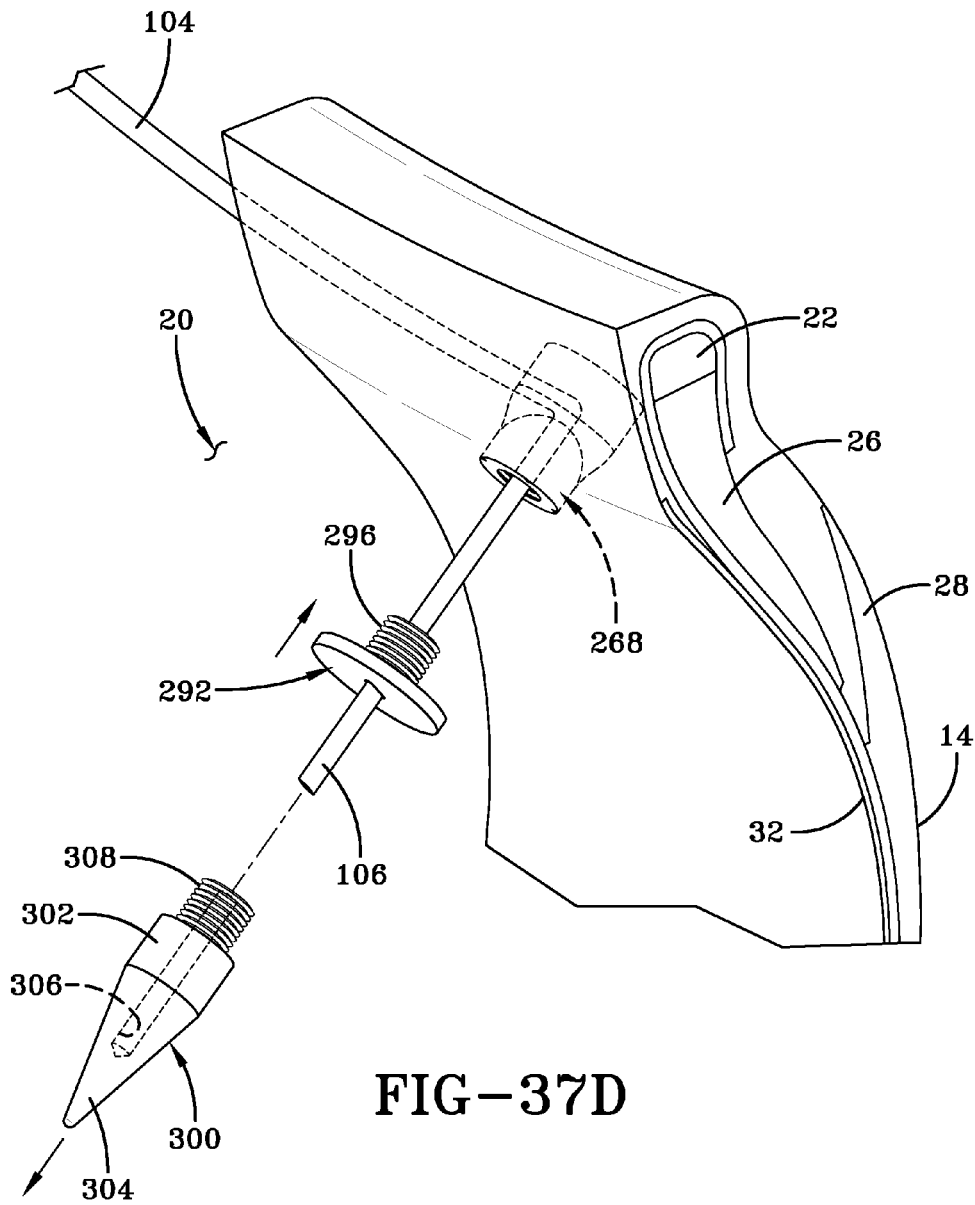

FIG-37C



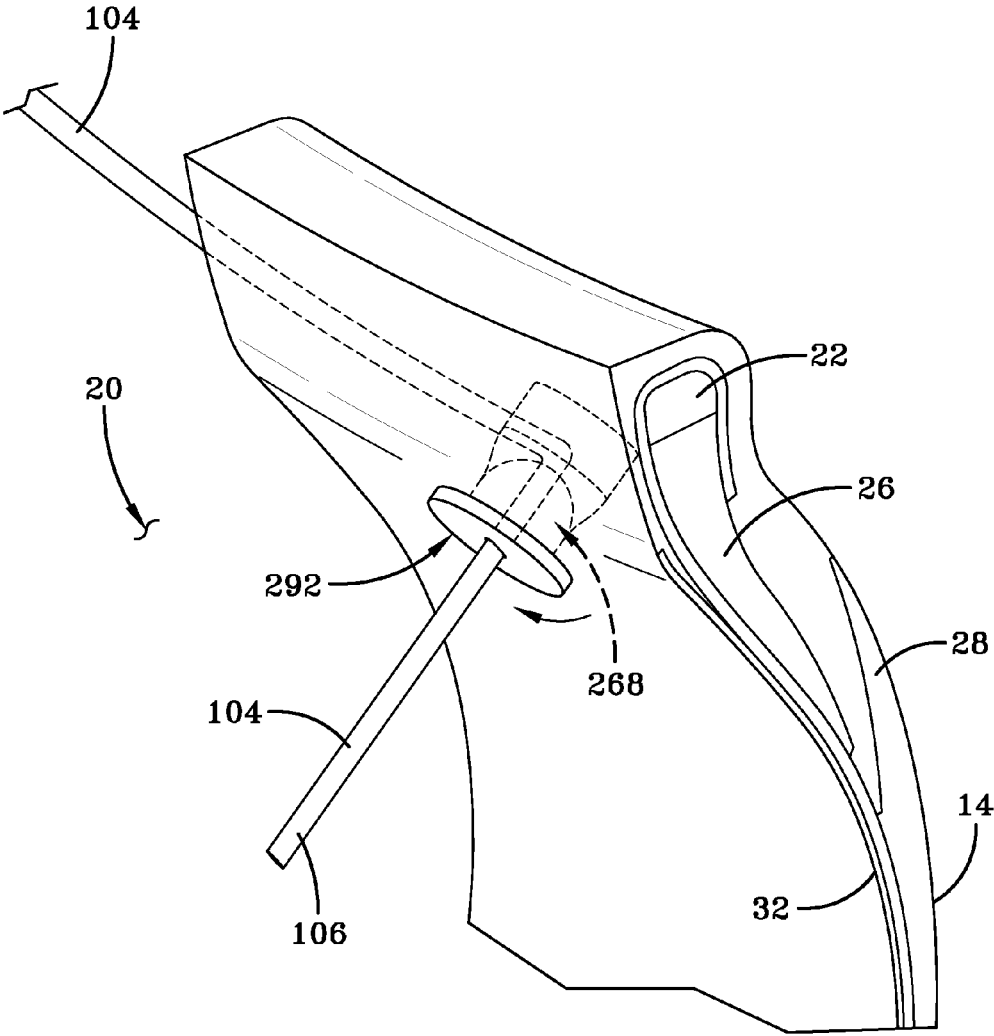

FIG-37E

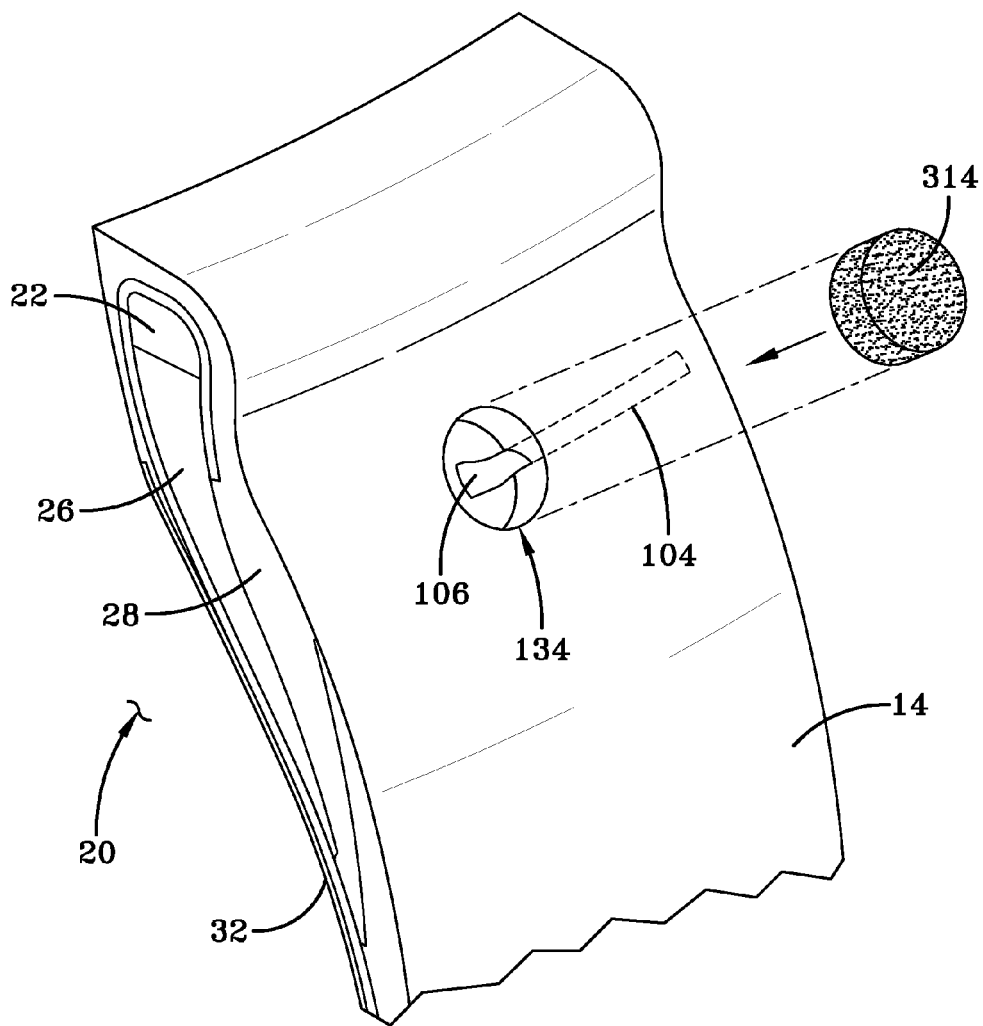

FIG-37F

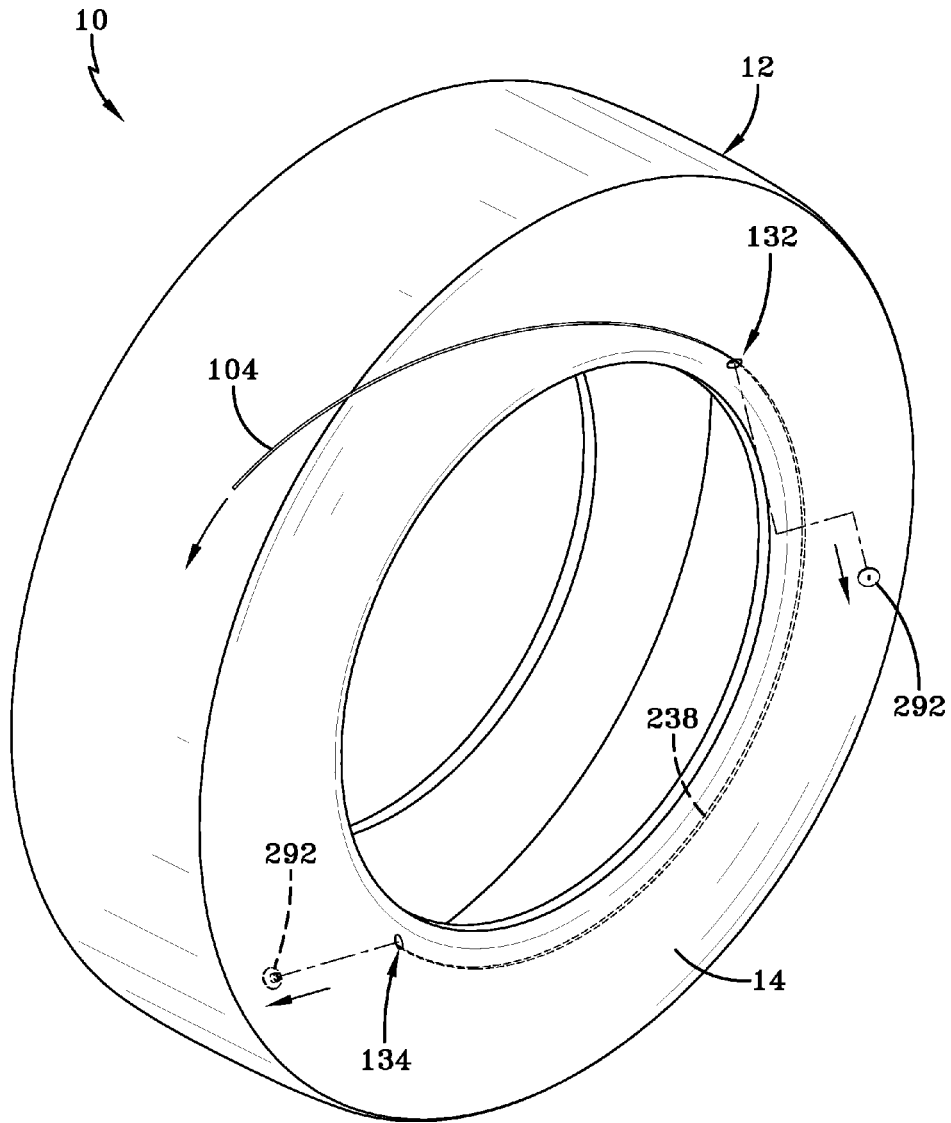

FIG-38

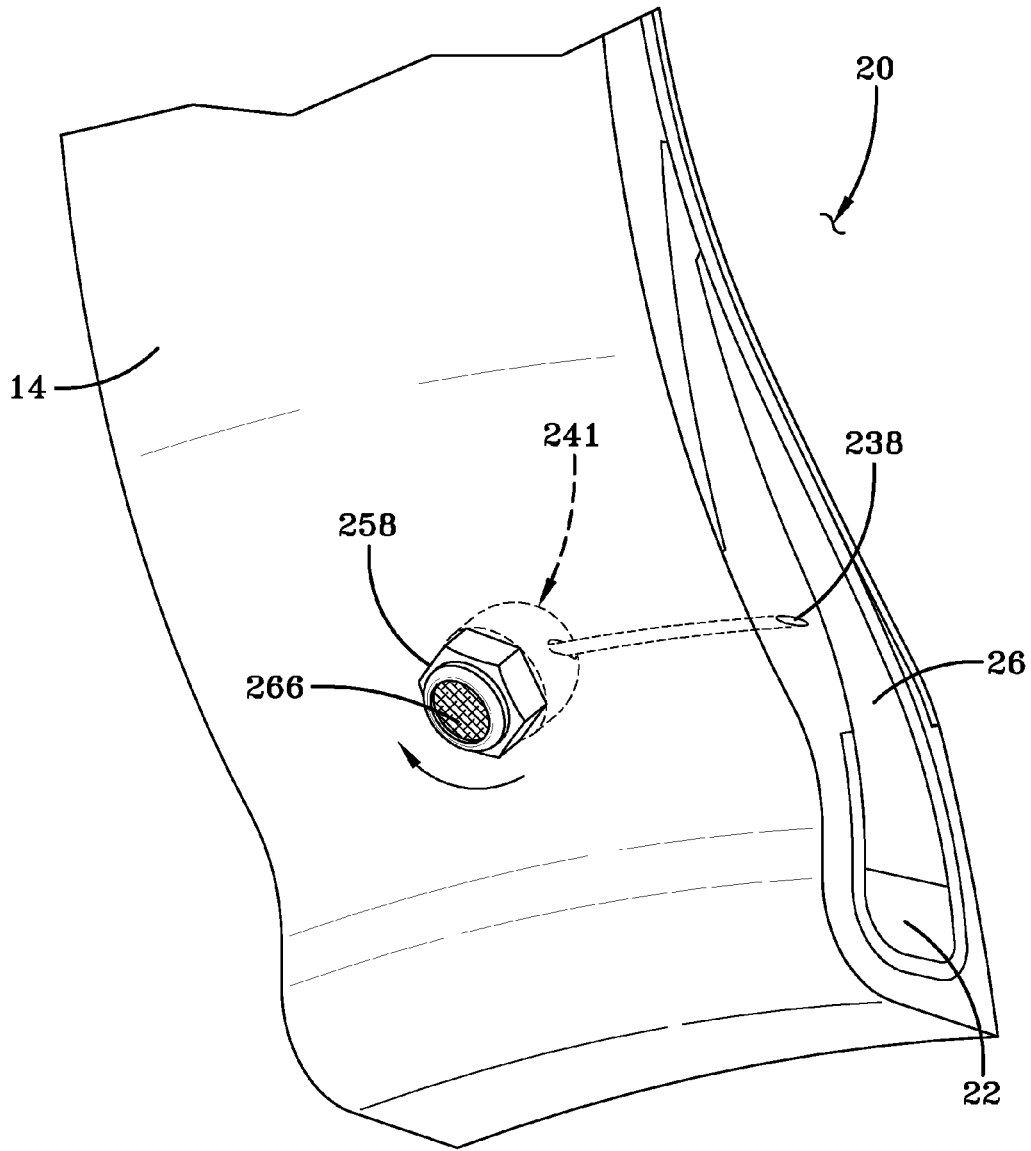

FIG-39

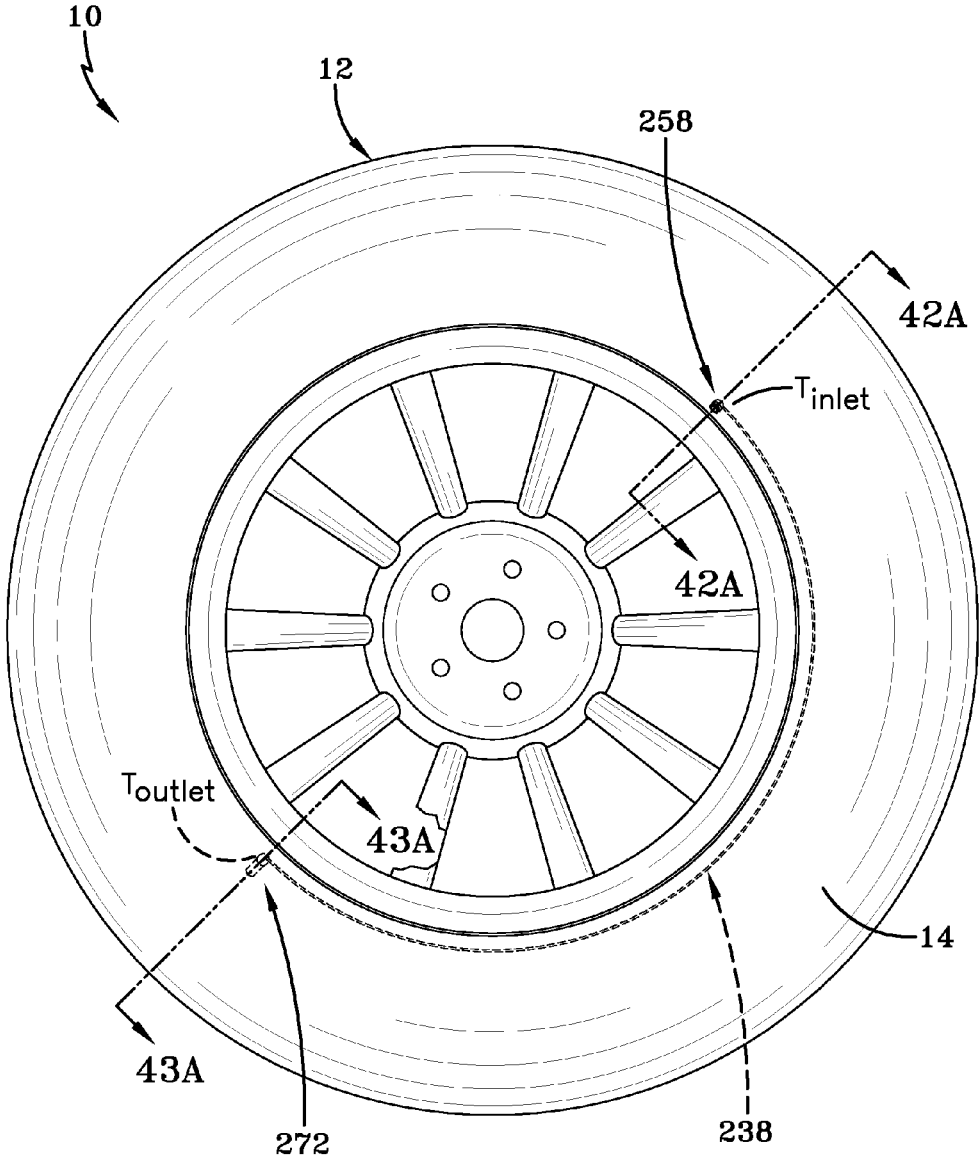

FIG-41

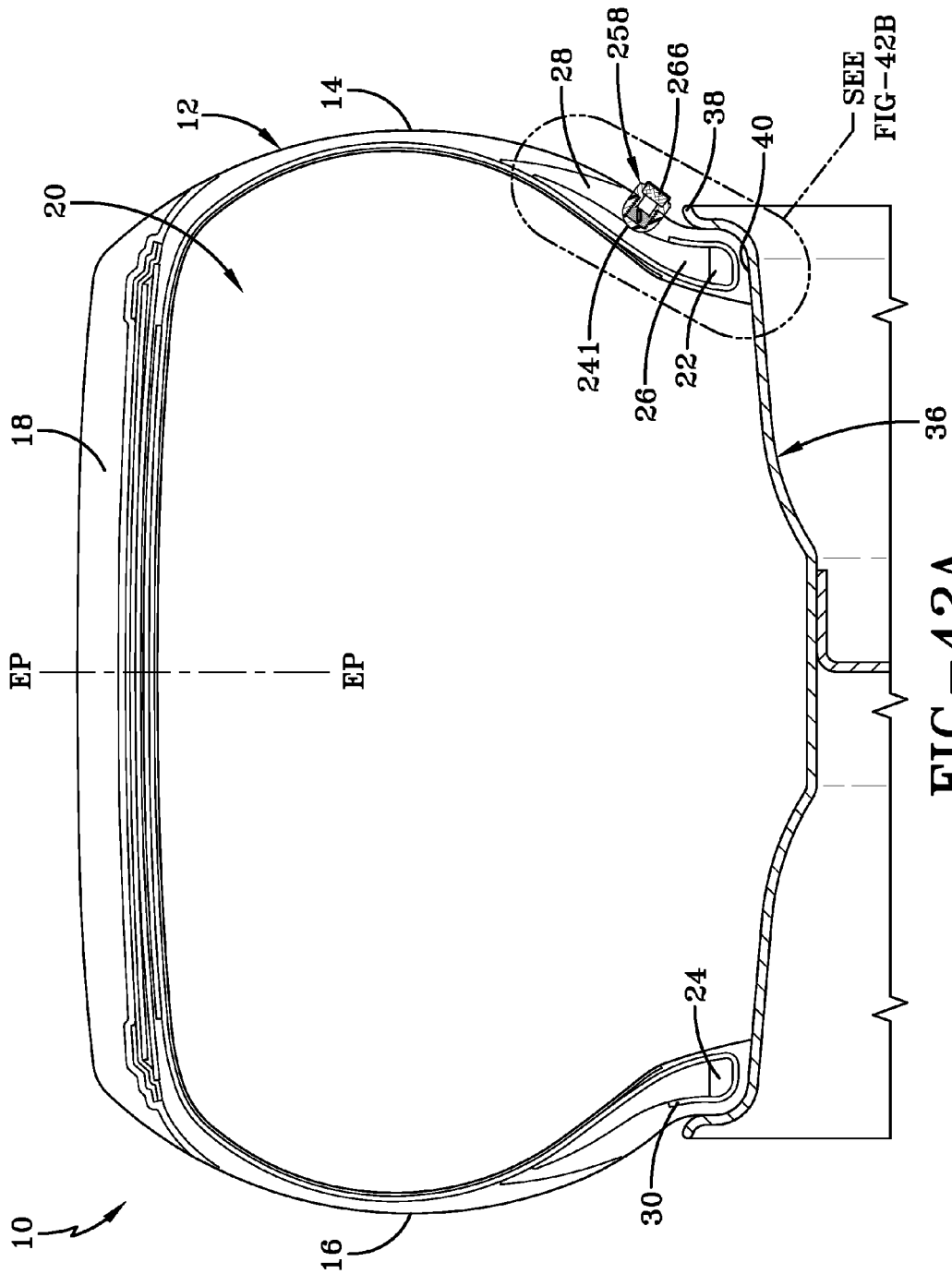

FIG-42A

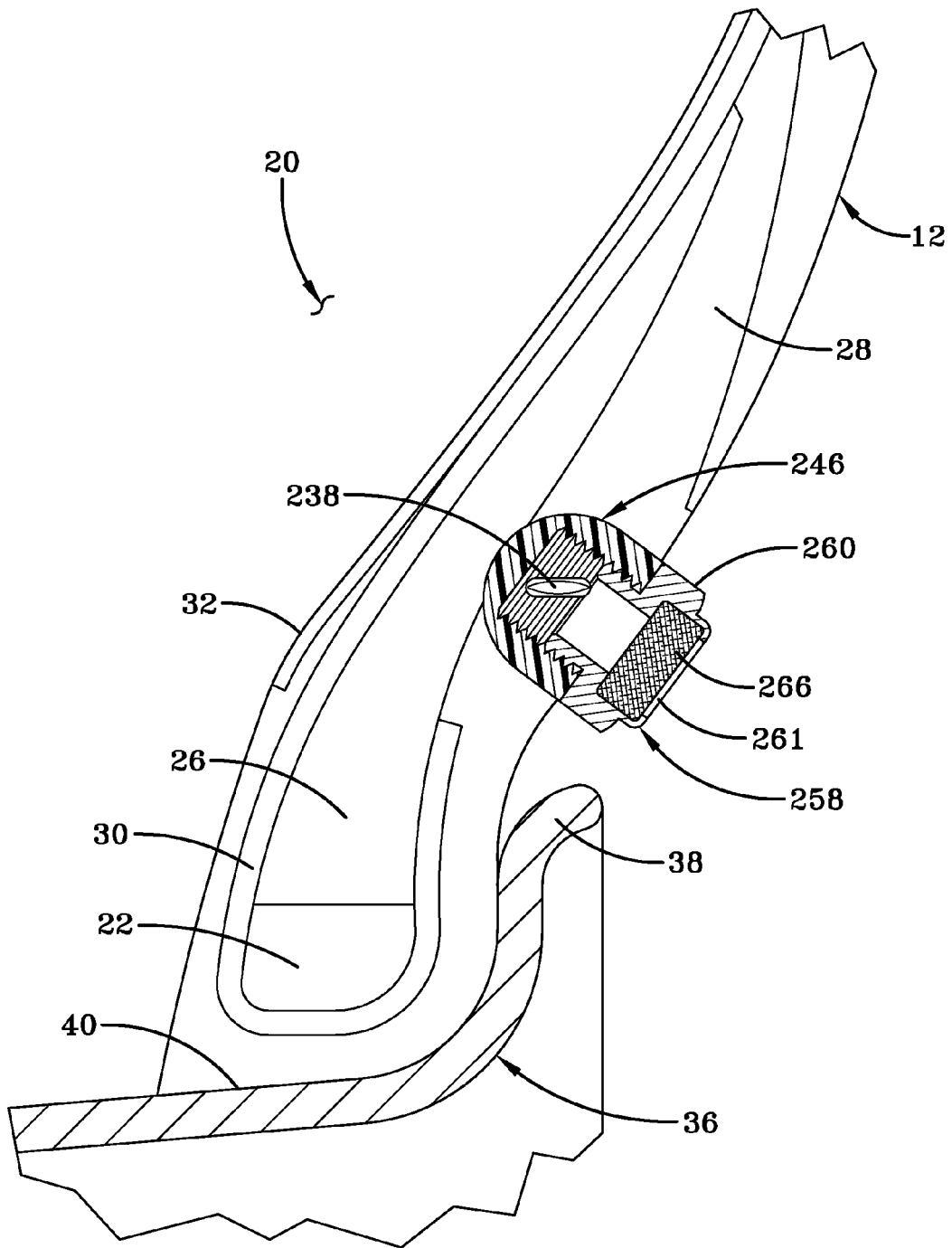

FIG-42B

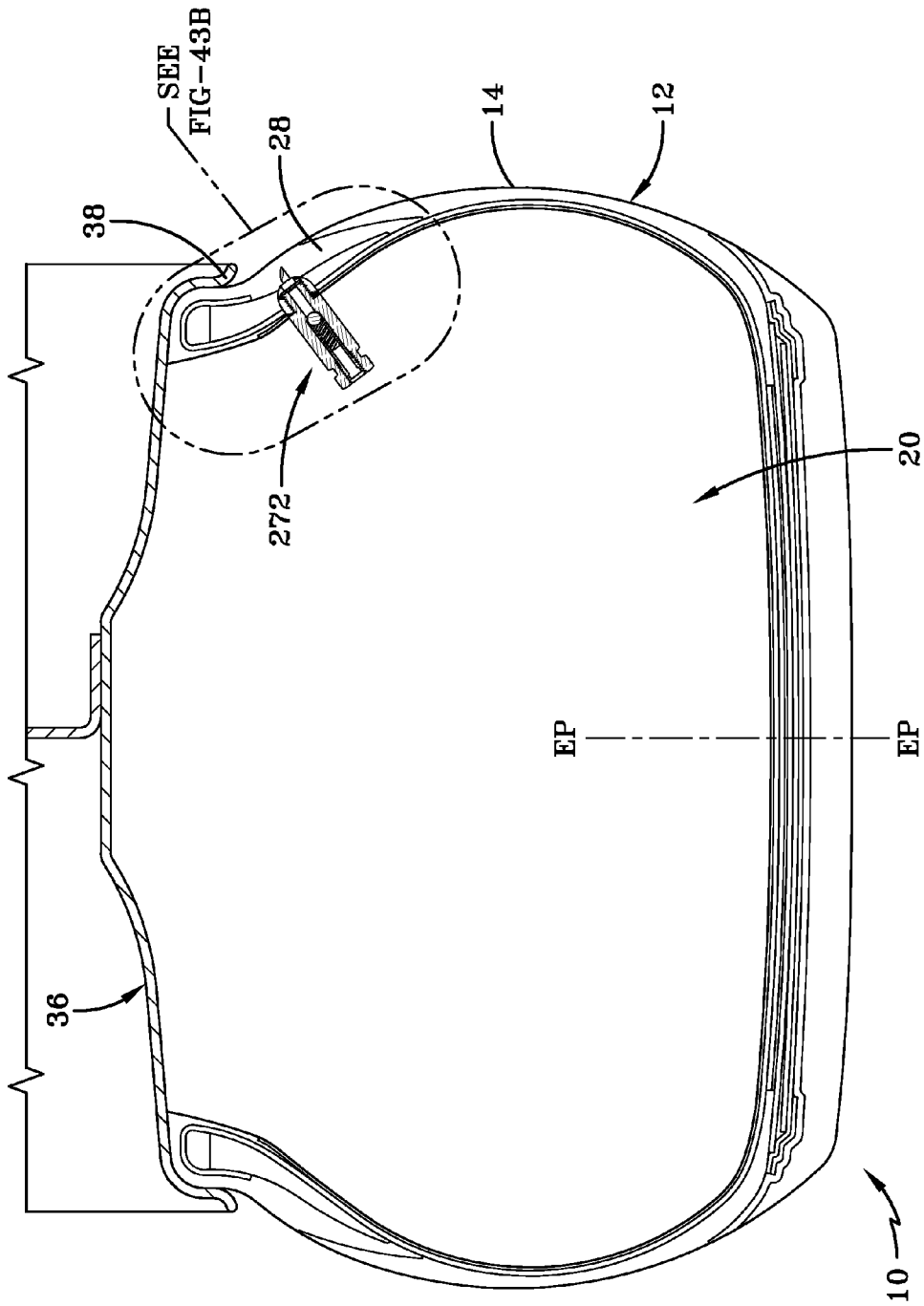

FIG-43A

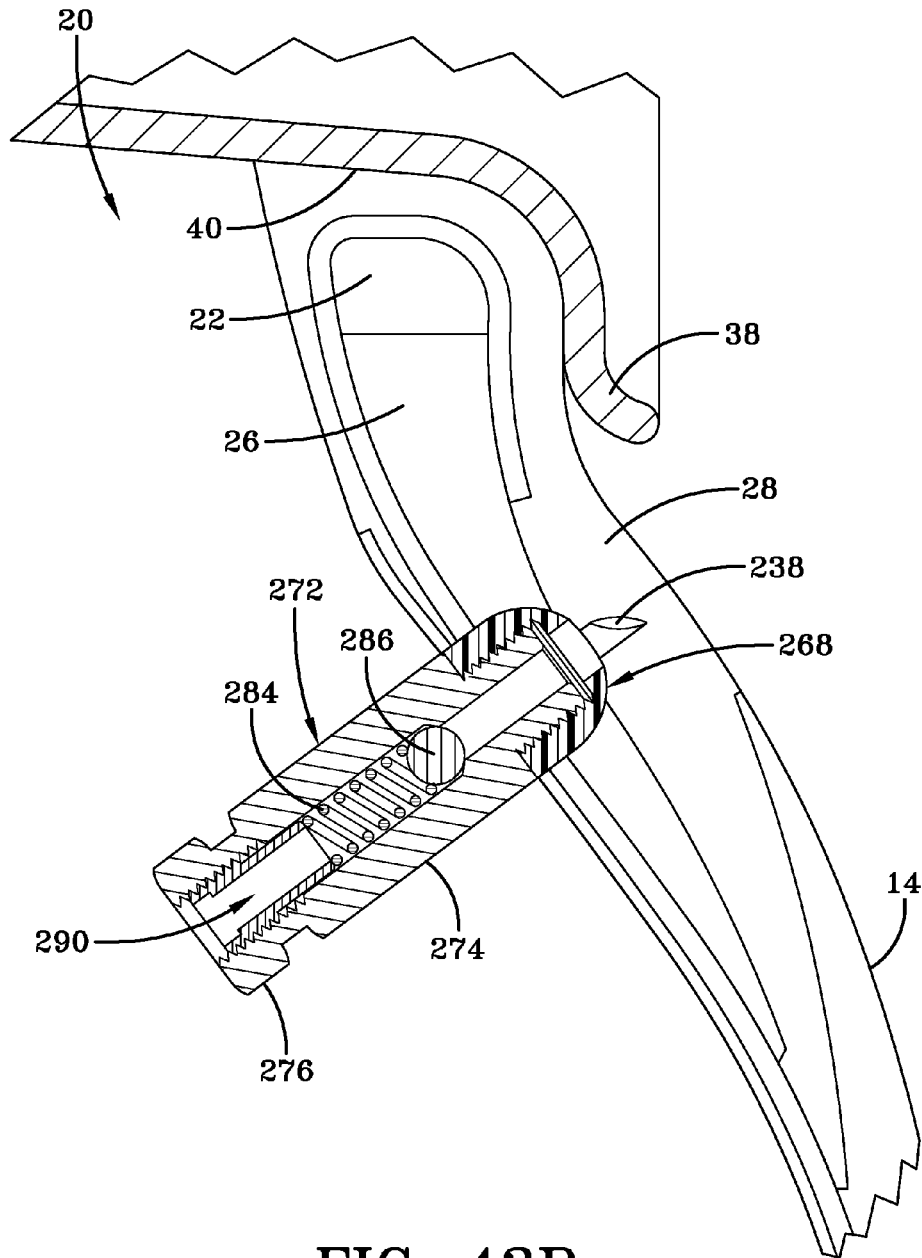

FIG-43B

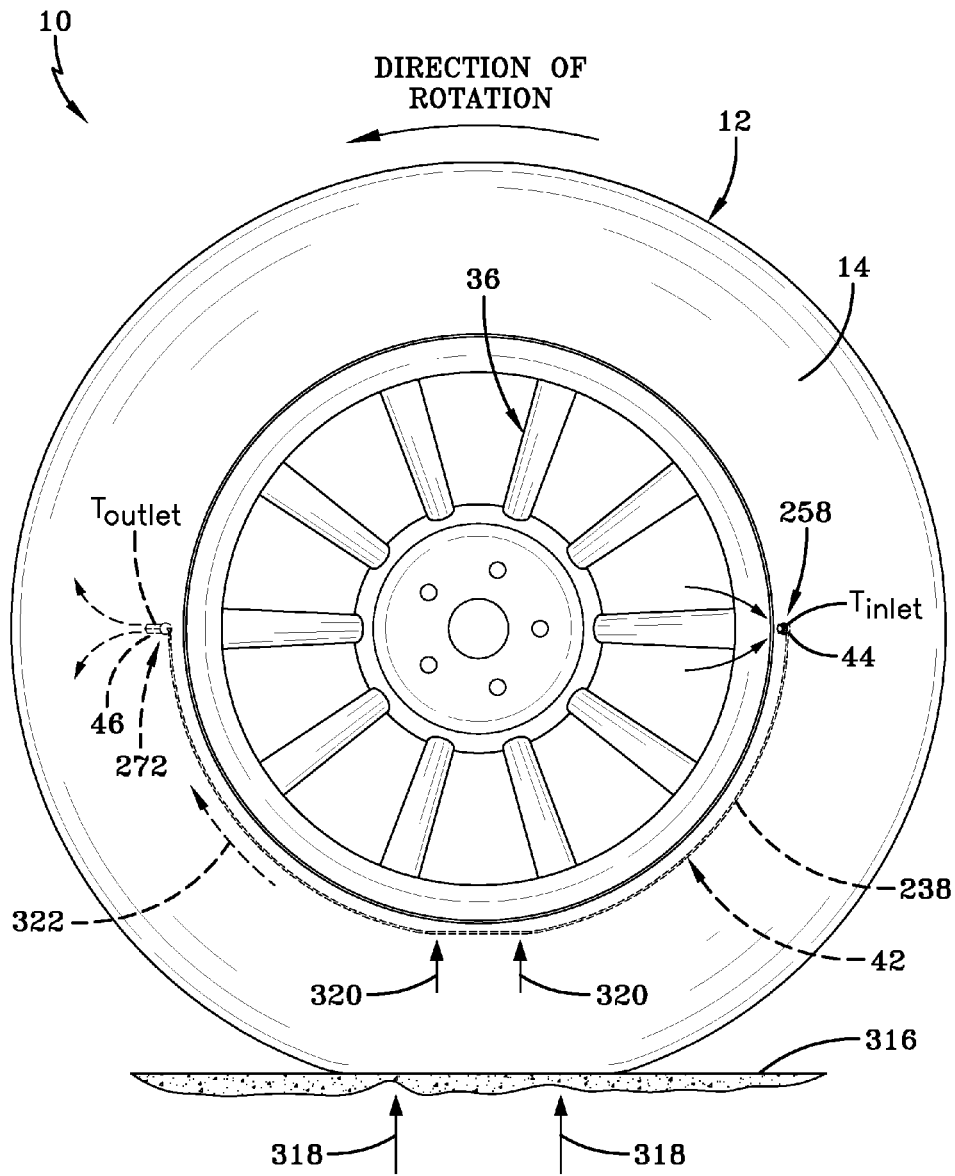

FIG-44

1

AIR MAINTENANCE TIRE AND CONNECTOR SYSTEM

FIELD OF THE INVENTION

The invention relates generally to air maintenance tires and, more specifically, to a connector system for construction of a built-in air maintenance pump assembly in a tire.

BACKGROUND OF THE INVENTION

Normal air diffusion reduces tire pressure over time. The natural state of tires is under inflated. Accordingly, drivers must repeatedly act to maintain tire pressures or they will see reduced fuel economy, tire life and reduced vehicle braking and handling performance. Tire Pressure Monitoring Systems have been proposed to warn drivers when tire pressure is significantly low. Such systems, however, remain dependant upon the driver taking remedial action when warned to re-inflate a tire to recommended pressure. It is a desirable, therefore, to incorporate an air maintenance feature within a tire that will re-inflate the tire in order to compensate for normal air diffusion over time without the need for driver intervention.

SUMMARY OF THE INVENTION

In one aspect of the invention, an air maintenance tire and connector system includes a tire carcass; an elongate integral air passageway contained within a flexible tire component of the tire carcass, the air passageway extending between an air inlet and an air outlet cavity in the flexible tire component, and a connector assembly inserted within one or both of the cavities. The connector assembly includes a hollow body having a central chamber, a protruding funnel housing portion extending from the hollow body, and a through-channel extending through the funnel housing portion to the central chamber. The connector assembly further provides a dependant coupling post extending from the hollow body, the coupling post having an axial length sufficient to project axially inward from the first cavity through a tire wall thickness to a tire central cavity. An axial air conducting through-bore extends through the coupling post from the hollow housing central cavity to a remote end of the coupling post positioned within the tire central cavity.

In another aspect, the remote end of the coupling post is operative for sequential alternative attachment to: a punch device for penetrating through the tire wall thickness to the tire central cavity; a capping nut attaching to the remote end of the coupling post and operative to enclose the axial post through-bore throughout a tire curing procedure; and a valve device attaching post-curing of the tire to the remote end of the coupling post, the valve device operative to regulate air flow between the hollow housing into the tire cavity.

DEFINITIONS

“Aspect ratio” of the tire means the ratio of its section height (SH) to its section width (SW) multiplied by 100 percent for expression as a percentage.

“Asymmetric tread” means a tread that has a tread pattern not symmetrical about the center plane or equatorial plane EP of the tire.

“Axial” and “axially” means lines or directions that are parallel to the axis of rotation of the tire.

2

“Chafer” is a narrow strip of material placed around the outside of a tire bead to protect the cord plies from wearing and cutting against the rim and distribute the flexing above the rim.

“Circumferential” means lines or directions extending along the perimeter of the surface of the annular tread perpendicular to the axial direction.

“Equatorial Centerplane (CP)” means the plane perpendicular to the tire’s axis of rotation and passing through the center of the tread.

“Footprint” means the contact patch or area of contact of the tire tread with a flat surface at zero speed and under normal load and pressure.

“Groove” means an elongated void area in a tire wall that may extend circumferentially or laterally about the tire wall. The “groove width” is equal to its average width over its length. A groove is sized to accommodate an air tube as described.

“Inboard side” means the side of the tire nearest the vehicle when the tire is mounted on a wheel and the wheel is mounted on the vehicle.

“Lateral” means an axial direction.

“Lateral edges” means a line tangent to the axially outermost tread contact patch or footprint as measured under normal load and tire inflation, the lines being parallel to the equatorial centerplane.

“Net contact area” means the total area of ground contacting tread elements between the lateral edges around the entire circumference of the tread divided by the gross area of the entire tread between the lateral edges.

“Non-directional tread” means a tread that has no preferred direction of forward travel and is not required to be positioned on a vehicle in a specific wheel position or positions to ensure that the tread pattern is aligned with the preferred direction of travel. Conversely, a directional tread pattern has a preferred direction of travel requiring specific wheel positioning.

“Outboard side” means the side of the tire farthest away from the vehicle when the tire is mounted on a wheel and the wheel is mounted on the vehicle.

“Peristaltic” means operating by means of wave-like contractions that propel contained matter, such as air, along tubular pathways.

“Radial” and “radially” means directions radially toward or away from the axis of rotation of the tire.

“Rib” means a circumferentially extending strip of rubber on the tread which is defined by at least one circumferential groove and either a second such groove or a lateral edge, the strip being laterally undivided by full-depth grooves.

“Sipe” means small slots molded into the tread elements of the tire that subdivide the tread surface and improve traction, sipes are generally narrow in width and close in the tires footprint as opposed to grooves that remain open in the tire’s footprint.

“Tread element” or “traction element” means a rib or a block element defined by having a shape adjacent grooves.

“Tread Arc Width” means the arc length of the tread as measured between the lateral edges of the tread.

BRIEF DESCRIPTION OF THE DRAWINGS

The invention will be described by way of example and with reference to the accompanying drawings in which:

FIG. 1 is a detail view of the silicone core die.

FIG. 2 is a perspective view of a basic silicone core extruder and conveyor.

FIG. 3 is a detail of a chafer die.

FIG. 4 is a perspective view of a basic chafer strip extruder and conveyor.

FIG. 5 is a dimensioned sectioned view of the silicone core.

FIG. 6 is a dimensioned sectioned view of extruded chafer strip.

FIGS. 7A through 7C are detailed views showing the silicone core strip being coated with soft rubber gum strip.

FIG. 8 is a detail view of the chafer strip with punched hole locations.

FIG. 9 is an enlarged perspective view of the silicone core strip being assembled into the chafer strip.

FIGS. 10A through 10C are sectioned views showing the coated silicone core and the chafer strip assembly.

FIG. 11A is a perspective view of a tire build up drum with assembled 180 degree core/chafer strip being applied, with a normal chafer strip placement on opposite end.

FIG. 11B is a perspective view of a tire build up drum with a normal 180 degree chafer strip being placed abutting the 180 degree core/chafer strip.

FIG. 12 is a perspective front view of a formed green tire showing inlet and outlet locations with the core strip extending from openings and the tire ready for core forming devices.

FIG. 13A is an enlarged sectioned view showing the inlet cavity and the silicone core ready for placement of the inlet core device.

FIG. 13B is an enlarged sectioned view showing the outlet cavity and the silicone core ready for placement of the outlet core device.

FIG. 14A is a top perspective view showing a first embodiment outlet core assembly with screw punch attached.

FIG. 14B is a bottom perspective view showing the outlet core assembly with screw punch removed and the nut attached.

FIG. 14C is a top exploded view of the outlet core assembly showing top/bottom core halves and mounting screw with the screw punch and hold down nut.

FIG. 14D is a bottom exploded view of FIG. 14C.

FIG. 15A is a top perspective view of a first embodiment inlet core assembly.

FIG. 15B is a top exploded view of the inlet core assembly showing top/bottom core halves and magnetic inserts.

FIG. 15C is a bottom exploded view of FIG. 15B.

FIG. 16A is a threaded elbow and valve housing assembly.

FIG. 16B is an exploded view of FIG. 16A showing the elbow, valve housing and Lee valve.

FIG. 17A shows an alternative embodiment of threaded elbow and one-way valve assembly.

FIG. 17B is an exploded view of FIG. 17A showing the elbow valve housing with air passage ways and membrane cover.

FIG. 18A is an enlarged sectioned view showing the inlet bottom core being inserted into the cavity under core strip and the chafer groove re-opened to allow room of the conical end of the inlet core to be fully seated into cavity.

FIG. 18B is an enlarged sectioned view showing the inlet bottom core fully inserted into the cavity and the core strip being trimmed to length.

FIG. 18C is an enlarged sectioned view showing the inlet top core ready for placement into the cavity.

FIG. 18D is an enlarged section view showing the inlet core assembly fully assembled into cavity.

FIG. 18E is an enlarged section view showing the inlet core assembly held in place with thin rubber patches is ready for curing.

FIG. 19A is an enlarged sectioned view showing the outlet bottom core unit being inserted into the cavity under the core strip and the punch forced through the tire wall into the cavity

chamber with the chafer groove re-opened to allow room for the conical end of the outlet core bottom unit to be fully seated into cavity.

FIG. 19B is an enlarged sectioned view of the bottom outlet core unit fully seated into the cavity.

FIG. 19C is an enlarged sectioned view from cavity side showing the screw punch fully inserted through the tire wall.

FIG. 19D is an enlarged sectioned view of the screw punch removed from the outlet bottom core half component with the nut attached to thread shaft.

FIG. 19E is an enlarged sectioned view showing the nut fully attached to the outlet bottom core shaft.

FIG. 19F is an enlarged sectioned view of the core strip cut to length at the outlet bottom core strip cavity.

FIG. 19G is an enlarged sectioned view of the outlet top core component placed into the cavity and screwed into place.

FIG. 19H is an enlarged sectioned view showing the outlet core halves and screw fully assembled.

FIG. 19I is an enlarged sectioned view showing the conical end of outlet core assembly covered with a rubber patch.

FIG. 20 is a side view of a tire showing the inlet and outlet core locations before curing.

FIG. 21A is a section view taken from FIG. 20 showing the inlet core location.

FIG. 21B is an enlarged view of the inlet core taken from FIG. 21A.

FIG. 22A is a section view taken from FIG. 20 showing the outlet core.

FIG. 22B is an enlarged view of the outlet core taken from FIG. 22A.

FIG. 23 is an enlarged sectioned view showing the inlet core halves being removed after curing.

FIG. 24 is an enlarged sectioned view showing the nut removed from the outlet core threaded shaft.

FIG. 25 is an exploded view of the outlet core halves disassembled and removed from the sidewall cavity.

FIG. 26 is a side elevation showing the silicone core strip removed from the tire sidewall.

FIG. 27 is an enlarged sectioned view showing the finished inlet cavity ready for permanent inlet insert placement.

FIG. 28A is an enlarged sectioned view showing the threaded elbow component placed into the outlet cavity.

FIG. 28B is an enlarged sectioned view showing the elbow component fully inserted through the sidewall to the cavity chamber with a leading end placed into conical opening and a rubber plug/patch ready to fill the opening.

FIG. 28C is enlarged sectioned view showing the patched area after 30 minute cure.

FIG. 29A is an enlarged sectioned view from the cavity chamber showing the outlet valve ready to be threaded onto outlet elbow component.

FIG. 29B is an enlarged sectioned view of the outlet valve shown fully seated onto the elbow component to thus complete the first embodiment operation.

FIGS. 30A through 30D are detailed views of a second, alternative, embodiment of the assembly including an inlet dome nut.

FIGS. 30E through 30H are detailed views of the outlet dome nut embodiment.

FIGS. 31A through 31C are detailed views of a second, alternative, embodiment of the inlet filter assembly.

FIGS. 32A through 32D are detailed views of a second embodiment of the outlet dome nut.

FIGS. 33A through 33C are detailed views of a second embodiment outlet valve.

FIGS. 34A and 34B are detailed views of dome nut cap.

5

FIGS. 35A and 35B are detailed views of a hollow needle component.

FIG. 36A is an enlarged sectioned view of a tire showing the core strip inserted through the inlet dome nut and the dome nut being placed into the formed inlet chafer opening.

FIG. 36B is an enlarged sectioned view showing a void around the inlet dome nut filled with chafer compound and the core strip inserted through the protective cap.

FIG. 36C is an enlarged sectioned view of the protective cap threaded into the inlet dome nut at the inlet location in anticipation of tire curing.

FIG. 37A is an enlarged tire section showing the core strip inserted through the outlet dome nut and pressed into the hollow needle opening.

FIG. 37B is an enlarged sectioned view showing the outlet dome nut and hollow needle assembled and placed into the formed outlet chafer opening and forced through the tire sidewall.

FIG. 37C is an enlarged detail view from the tire cavity showing the hollow needle fully inserted through the green tire sidewall.

FIG. 37D is an enlarged detail view showing the hollow needle removed from the outlet dome nut and the core strip inserted through the protective cap.

FIG. 37E is a detail view showing the protective cap threaded into the outlet dome nut.

FIG. 37F is an enlarged detail view showing the outlet chafer opening fully filled with chafer compound at the outlet location in anticipation of tire curing.

FIG. 38 is a side elevation view of the tire after curing, showing the protective caps removed from both the inlet and outlet dome nuts and the silicone core strip being removed from tire sidewall.

FIG. 39 is an enlarged detail view showing the filter threaded into the inlet dome nut.

FIG. 40 is an enlarged detail view showing the one-way valve threaded into the outlet dome nut.

FIG. 41 is a side view of the finished 2nd embodiment tire assembly.

FIG. 42A is a section view taken from FIG. 41 showing the location of the inlet dome nut with attached filter.

FIG. 42B is an enlarged view of the inlet and filter taken from FIG. 42A.

FIG. 43A is a section view taken from FIG. 41 showing the location of the outlet dome nut with attached one-way valve.

FIG. 43B is an enlarged view of the outlet dome nut and one-way valve taken from FIG. 43A.

FIG. 44 is a side view of the finished tire showing air flow from inlet to outlet located in the tire cavity.

DETAILED DESCRIPTION OF THE INVENTION

Referring initially to FIGS. 38, 41, 44, 42A and 42B, an air maintenance assembly and tire system 10 is shown. The system incorporates air maintenance apparatus with a tire for the purpose of maintaining air pressure within the tire at a desired level without operator intervention. The system 10 includes a tire 12 of generally conventional construction and including a pair of sidewall components 14, 16 and a tread 18 enclosing a tire cavity 20. The sidewalls 14, 16 extend from a pair of tire beads 22, 24 to the tread 18. Pursuant to conventional construction, the tire 12 has an apex component 26 disposed radially adjacent each bead and a chafer component 28 surrounding each bead region. The tire 12 mounts to a wheel 36 and is seated on a rim surface 40. An air maintenance assembly 42, as will be explained, may be provided within one or both sides of the tie 12 if desired. Each air maintenance

6

assembly 42 is configured to extend between an air entry or inlet cavity 44 and an air exit/outlet cavity 46. Pursuant to the invention, the air maintenance assembly 42 incorporates a thin tube as a hollow within a flexible tire component such as the chafer 28 during tire construction. The location selected for the hollow tube within the tire is in a tire component residing within a high flex region of the tire sufficient to progressively collapse the peristaltic internal tire tube as the tire rotates, whereby forcing air along the tube from the inlet to the outlet where the air is directed to the tire cavity for pressure maintenance. The AMT assembly 42 thus operates as an internal peristaltic air pump to the tire.

With reference to FIGS. 1, 2, 3, 4, 5 and 6, a silicone core strip 58 is formed by means of die 48 having a profiled orifice 50 therethrough. The orifice is elongate and generally lens shaped in section with the extruded strip 58 of like sectional geometry. The lens shape may have a dimension of, by way of example without limitation intent, 2.7 mm length D2×0.5 mm at D1. While the preferred composition of the strip 58 is silicone, other materials such as cable or monofilament may be used if desired. The die 48 is affixed to a basic extruder of conventional configuration and deposits a formed core strip 58 on a conveyer belt moved by drive roller 56. The length of the strip 58 is predetermined as will be appreciated from the explanation following. As shown in FIGS. 3 and 4, a chafer strip 70 is formed by extrusion die 60 affixed to extruder 66 and deposited on roller 68. The die 60 is formed having along a chafer forming opening 62 along a bottom side and a downward projection finger 64 projecting into the opening 62. FIG. 6 shows a sectioned view of the extruded chafer strip. As seen, the strip 70 widens in section from a low width or thinner end region 72 to a stepped wider or thicker region 74 to a wider or thicker opposite region 88. The die finger 64 forms an incut, arching chafer channel or tube 80 extending the length of the chafer strip, defined by channel sidewalls 82, 84 and bottom wall 86. The channel is open initially as shown at 90. Representative dimensions as seen in FIG. 6 are within a range of 25 to 100 mm; L2=13+/-10; L3=1+/-0.5; H1=5+/-4; and H2=4.5+/-4; however the chafer strip dimensions may be varied to suit the particular tire sizing needs and the tire construction characteristics desired. In addition, if so desired, the silicone strip 58 may be molded instead of extruded.

A flexible tire component, such as a chafer segment, is provided with a groove 80, as best seen in section from FIG. 6, is defined by groove lips 82, 84 that angle inwardly from top to bottom to a bottom groove wall 86. The groove 80, formed within a axially outward thicker side 88 of the chafer strip is accordingly open at groove opening 90. The groove 80 formed within the chafer is as a result angles axially outward from the opening 90 to the bottom wall 86 at an acute angle θ preferably within a range of -20 to +20 degrees. As shown in FIGS. 7A through 7C, the silicone strip 58 can be enveloped within an outer sheath or covering 92 formed of rubber gum or other suitable material. The rubber gum strip 92 is folded over the strip 58 to form an overlap seam 94 to enclose the silicone strip 58 and thus forms therewith a sheathed silicone strip assembly 104. The strip assembly 104, as explained following, will be used to form peristaltic tube within a green tire during green tire construction. The general purpose of strip assembly 104 is to form within a green tire component, such as chafer 28, a core air passageway which, once the strip assembly is removed, forms a peristaltic tube integrally within and enclosed by the tire component. The angled groove 80 is formed within the chafer strip as a slot, with the lips 82, 84 in a close opposed relationship. The groove 80 is then opened to receive the strip assembly 104 by an elastic spreading apart of groove lips 82, 84. Thereafter, the assem-

bly **104** is positioned downward into the groove **80** until reaching a position adjacent to the bottom wall **86**. A release of the lips **82**, **84** causes the lips to elastic resume their close opposed original orientation. The lips **82**, **84** are then stitched together in a rolling operation wherein a roller (not shown) presses the lips **82**, **84** into the closed orientation shown in FIGS. **6** and **8** and become entrapped within the chafer strip by a folding over the chafer strip over the top as seen in FIG. **10C**. The angle θ of the channel **80** with respect to a bottom surface of the chafer strip enables a complete capture of the silicone strip assembly **104** within the tire component, chafer **28**, entirely surrounded by the chafer strip material composition.

With reference to FIGS. **8**, **9**, **10A** through **10C** and **7A** through **7C**, the channel **80** is destined to become the tube component to a peristaltic pump assembly within the tire chafer **70** and generally extends from chafer strip end **96** to end **98**. The chafer is cut at a given length depending on the pump length that is desired when the tire is cured. Formed within each end of the chafer by a punching operation or cutting operation are enlarged diameter circular holes **100**, **102**. The holes **100**, **102** are adjacent the ends of the channel **80** and are sized to accommodate receipt of peristaltic pump inlet and outlet devices as will be explained. The lips **82**, **84** of the chafer channel **80** are pulled apart. The wrapped silicone strip assembly **104** is inserted at direction arrow **110** into the channel **80** as shown in FIGS. **10A** through **10C** until adjacent and contacting the lower wall **86** of the channel **80**. Thereupon, the silicone strip assembly **104** is enclosed by the chafer by a folding over of the chafer lip flap **82** in direction **112**. The channel **80** is thus closed and subsequently stitched in the closed position by a pair of pressure contact rolls (not shown). So enclosed, the assembly **104** will preserve the geometry of the channel **80** from green tire build until after tire cure when the assembly **104** is removed. The silicone strip assembly **104** is dimensioned such that assembly ends **106**, **108** extend free from the chafer strip **70** and the chafer strip channel **80**, and extend a distance beyond the punched holes **100**, **102** at opposite ends of the chafer strip.

Referring to FIGS. **11A**, **11B** and **12**, a conventional green tire building station is depicted to include a build drum **116** rotational about an axial support **118**. The chafer strip **70** containing silicone strip assembly **104** and an opposite chafer strip **122** that does not incorporate a strip assembly **104** are positioned along opposite sides of the build drum **116** in direction **124** in an initial 180 degree chafer build-up. The chafer strip **70** is thus combined with a normal chafer strip **126** length to complete the circumference. The second strip **126** is applied to the building drum in alignment with and abutting strip **70** as shown in FIG. **11B** to complete a 360 degree chafer construction on the drum. The opposite side of the drum receives two 180 degree normal strips **122** in abutment to complete the chafer build on that side. It will be noted that the chafer strip **70** contains the silicone strip assembly while the abutting strip **126** does not. However, if desired, both of the chafer strips **70**, **126** as well as one or both of the strips **122** may be configured to contain a silicone strip assembly **104** to create a 360 degree peristaltic pump tube on one side or both sides of the green tire. For the purpose of explanation, the embodiment shown creates a pumping tube of 180 degree extent in one chafer component only. In FIG. **11B**, it will be noted that chafer strip **126** is configured to complement the construction of strip **70** shown in FIGS. **8** and **9**. Circular punch holes **100**, **102** are at opposite ends of the complementary strip **126**. When abutted against the strip **70**, the punch holes **100**, **102**, create 180 degree opposite cavities **132**, **134** as seen in FIGS. **13A** and **13B**.

The free end **106** for the purpose of explanation will hereafter be referred to as the "outlet end portion" of the silicone assembly **104** extending through the outlet cavity **134**; and the free end **108** the "inlet end portion" of the assembly **104** extending through the circular inlet cavity **132**. FIG. **12** illustrates the 180 degree extension of the silicone assembly **104** and FIGS. **13A**, **13B** show the relative location of the assembly **104** to the lower tire bead and apex components. FIG. **13A** shows the inlet cavity **132** and silicone core assembly **104** ready for placement of a temporary inlet core device and FIG. **13B** shows the outlet cavity **134** ready for placement of a temporary outlet core device.

FIGS. **14A** through **14D** show a first embodiment of a pre-cure, temporary outlet core assembly **136** with attached screw punch **138** and replacement nut **140**. The temporary outlet core assembly **136** includes mating bottom half-housing component **142** and a top half-housing component **144** connecting by means of a coupling screw **160**. The bottom half-housing component **142** has a dependent cylindrical screw threaded sleeve **146**; an upper socket **148** extending downward into the component **142** and communicating with the upward facing opening of sleeve **146**; and a half-protrusion **150** having an axial half-channel formed to extend across housing **142**. The top-half-housing component **144** has a central through bore **154**, a half-protrusion housing **156** and a half-channel formed to extend side to side across an underside of the housing **144**. United as shown in FIGS. **14A** and **14B**, the two half-housing components **142**, **144** are assembled by screw **160** threading bolt **162** down through the bore **154** and into the sleeve **146**. So assembled, the half-protrusion housings **150** and **156** unite as well as the half-channels **152**, **158**. In the assembled state, as seen in FIGS. **14A** and **14B**, the protrusion housings **150**, **156** form an outwardly projecting conical tube-coupling protrusion **164** away from the combined housing halves **142**, **144** and defining an axial air passageway channel **165** having a sectional shape and dimension corresponding with the silicone strip assembly **104** within chafer strip **126** of the tire.

The inwardly and outwardly threaded shaft **146** of the temporary outlet core assembly **136** receives and couples with an externally threaded shaft **168** of the screw punch accessory device **138**. As will be explained below, screw punch device **138** will in the course of peristaltic tube assembly formation be replaced with the threaded collar or nut **140** as shown in FIG. **14B**.

With reference to FIGS. **15A** through **15C**, a metallic first embodiment of a pre-cure, temporary inlet core assembly **170** is shown forming a housing body **174** from which a conical coupling housing protrusion **172** extends. An axial air passageway through-channel **176** extends through the housing body **174** and the protrusion **172** having a sectional shape and dimension corresponding with the shape and dimensions of the silicone strip assembly **104** within the chafer strip **126** of the green tire. The housing body **175** is formed by a combination of half-housing **178**, **180**, each providing a half-coupling protrusion **182**, **194**, respectively in which a half-channel **184**, **196** is formed, respectively. A central assembly socket **186** extends into the internal underside of half-body **178** and receives an upright post **188** from the lower half-body **180** to center and register the two half-bodies together. Three sockets **190** are formed within the lower half-body **180** with each socket receiving a magnetic insert **192**. The magnets **192** operate to secure the metallic half-housings **178**, **180** together.

Referencing FIGS. **16A** and **16B**, a threaded elbow and valve housing assembly **198** is shown for use as a permanent outlet core valve assembly. The housing assembly **198** is

formed of a suitable material such as a nylon resin. The assembly **198** includes an elbow housing **200** having a conical remote end **202** and a cylindrical valve housing **2004** affixed to an opposite end. A one-way valve, such as a Lee valve, is housed within the valve housing **204**. An axial air passageway **2008** extends through the L-shaped assembly **198** and through the Lee valve seated in-line with the passageway. A Lee valve is a one-way valve which opens at a prescribed air pressure to allow air to pass and is commercially available from The Lee Company, located in Westbrook, Conn., U.S.A. Other valve devices may be employed alternatively, such as a Norgren valve commercially available from Norgren N.V., located in Lot, Belgium, or a Beswick valve commercially available from Beswick Engineering located in Greenland, N.H., U.S.A.

FIGS. **17A** and **17B** show an alternative embodiment of an elbow connector and one-way post-cure outlet valve assembly **210**. An L-shaped elbow connector housing **212** has a conical forward arm end **214** and an axial passageway **216** that extends through the L-shaped housing **212**. An umbrella-type valve **218** of a type commercially available from Mini-Valve International located in Oldenzaal, The Netherlands, attaches to a threaded end of housing **212** by means of nut **220**. The valve **218** has a circumferential array of air passages **227** that allow the passing of air from the housing of the valve. The valve **218** includes an umbrella stop member **222** having a frusto-conical depending protrusion **224** that fits and locks within a valve central bore **226** and a flexible circular stop membrane **223**. The protrusion **224** of stop member **222** locks into the axial bore **226**. The flexible membrane **223** is in a closed or down position when air pressure on the membrane is at or greater than a prescribed pressure setting. In the down position, membrane **223** covers the apertures **227** of the valve body and prevents air from passing. The membrane **223** moves to an up or open position when the air pressure outside the membrane falls to a pressure less than the preset pressure setting. In the up or open position, air can flow from the apertures **227** into the tire cavity.

FIGS. **18A** through **18D** represent sequential views showing the installation of the inlet core assembly embodiment of FIGS. **15A** through **15C** connecting into the green tire silicone strip assembly **104** after green tire build and prior to curing of the green tire. In FIG. **18A**, the bottom half housing component **180** is inserted into the inlet cavity **132** after the cavity **132** has been enlarged into generally a key shape as indicated by the scissor representation. The cutting implement opens the chafer strip groove, still occupied by silicone strip assembly **104**, to accommodate receipt of the conical half-protrusion **194** of half-housing **180**. The tapered end of conical half-protrusion **194** fits into the chafer channel occupied by strip assembly **104** as shown in FIG. **18B**, as the strip assembly **104** is positioned within the half-channel **196** across the housing **180**. The extra length of inlet end portion **108** is cut and removed, whereby positioning a terminal end of the strip assembly **104** within the housing component **180**. The upper, outer, top half-housing component **178** is thereupon assembled over the housing component **180**, as seen in FIG. **18D**, capturing the strip assembly **104** within the channel formed by upper and lower half-channels **184**, **196**. The magnets **192** secure the metallic half-housings **178**, **180** together. Rubber patches **228**, **230** as seen in FIG. **18D** are applied over the temporary inlet core assembly **170** to secure the assembly in place for the tire cure cycle. The hollow metallic housings **178**, **180** are held together by the magnets. It will be appreciated that a non-metallic hollow housing may be employed if desired, such as a hollow housing made of molded plastic,

with housing components held together by locking detent techniques known in the plastic casing art.

FIGS. **19A** through **19I** show sequential assembly of the outlet core assembly embodiment of FIGS. **14A** through **14D** into the green tire outlet cavity **134** and to the outlet end portion **106** of the silicone strip assembly **104**. In FIG. **19A**, the bottom half-component **142** is inserted into the cavity **134** after the circular cavity **134** has been enlarged into a keyhole configuration to accommodate the geometry of the component **142**. The screw punch **138** is pushed through to protrude through tire wall into the tire cavity **20** from the cavity **134** as seen in FIG. **19C**. FIG. **19B** shows the component **142** fully seated into the cavity **134**, the tapered conical half-protrusion **159** projecting into the chafer channel occupied by strip assembly **104** with the strip assembly **104** residing within half-channel **152**. In FIGS. **19D** and **19E**, the screw punch **138** is removed and replaced by the nut **140** attached to the screw thread **146**. In FIG. **19F**, the outlet end portion **106** of silicone core strip **104** is cut to length at the outlet cavity **134** and placement of the outlet top half-housing **144** over the bottom half-housing **142** within cavity **134**. The screw **160** is threaded at **162** into socket **148** to affix both half-housings **142**, **144** together as shown in FIGS. **19G** and **19H**. A rubber patch **234** is affixed over the outlet core assembly **136** in place for tire cure.

FIGS. **20**, **21A**, **21B**, **22A** and **22B** show the tire with the inlet and outlet temporary core assemblies in place before curing. As seen, the silicone core assembly **104** enclosed within a chafer component **28** of the green tire extends 180 degrees between the pre-cure outlet core assembly **136** and the pre-cure inlet core assembly **170**. An enlarged depiction of the inlet core location is shown in FIG. **21B** from section view FIG. **21A** and the outlet core location is shown enlarged in FIG. **22B** from the section view of FIG. **22A**. The silicone core assembly **104** resides enclosed within the chafer channel and thereby preserves the structural integrity of the chafer channel through tire cure. The sectional configuration of the assembly **104**, as seen, is complementary to chafer channel in which it is encased surrounded by chafer composition, and thereby maintains the configuration of the chafer channel throughout tire cure.

Referring to FIG. **23**, the post-cure removal of the half-housings **178**, **180** from the inlet cavity **132** is shown. The cavity **132** is thus opened including a funnel-shaped cavity portion **233**. FIGS. **24** and **25** show the nut **140** removed from the outlet core threaded shaft **146** to initiate a post-cure removal of the outlet core assembly **136**. The assembly components **142**, **144** are removed from the outlet cavity **134**, leaving the cavity **134** including funnel-shaped adjacent cavity portion **237** open. Thereafter, as shown by FIGS. **26** and **27**, the silicone core strip assembly **104** is removed from the tire chafer channel, whereby the chafer channel left by the vacated core strip assembly **104** becomes an elongate unobstructed 180 degree air passageway **238** from the inlet cavity **132** to the outlet cavity **134**, wholly integrated within the chafer component **28**. FIG. **27** shows the post-cure insertion of permanent inlet cavity assembly **240** into the inlet cavity **132**. The assembly **240** includes a hollow casing **241** having an internal cavity (not shown) housing a porous air filter (not shown). The installed casing **241** replicates the configuration and shape of the hollow housing **170** described in reference to FIG. **15A**. A conical coupling protrusion **235** extends from the casing **241** and into the funnel cavity **233** off the inlet cavity **132**. The protrusion **235** has an internal air passageway which communicates with the cavity within casing **241**. An air inlet opening **239** is disposed within an outward face of the casing **241** to allow air to enter into the casing **241** and, from

there, to the air passageway within protrusion 235, and then into the integral chafer air passageway 238.

With reference to FIGS. 28A, 28B and 28C, the permanent outlet cavity insert assembly 198 in the embodiment shown in FIGS. 16A and 16B is inserted post-cure into the outlet cavity 134. The conical coupling protrusion 202 is seated within the funnel cavity 237 off the outlet cavity 134 while the L-shaped housing 200 seats within the cavity 134. The threaded coupling end 242 of the assembly 198 depends from the cavity 134 and projects into the tire cavity as shown in FIGS. 29A and 29B. Air flow along post-cure air passageway 238 toward the outlet assembly 198 is captured within the axial bore 208 and directed within the housing 200 to the threaded end 242. As seen in FIG. 28B, a plug 244 formed from rubber or a rubber composite or other suitable material, is inserted into the outlet cavity 134 to enclose the assembly 198 therein.

In FIGS. 29A and 29B, a valve mechanism such as valve assembly 198 (FIGS. 16A and 16B), that attaches to the screw threaded end 342 of the post-cure outlet cavity insert assembly 198 from the tire cavity 20 side. The valve assembly 198 opens when the pressure inside the pump tube is greater than the pressure inside the cavity 20 (plus the valve cracking pressure). The L-shaped elbow assembly 198 directs air from the chafer air passageway 338, through the axial passageway 208 of housing 200, into the housing 204 of the valve mechanism. The conical seating between end 202 and the conical entryway 237 into passageway 338 ensures that that air from the chafer passageway 338 is effectively routed into the elbow valve assembly 198.

FIGS. 30A through 30D are views of an alternative, second embodiment of an inlet cavity insert assembly incorporating a dome nut 246. The dome nut 246 has a rounded domed body 248, a center cavity 250, and internal coupling threads 252. Extending through a side of the dome body 248 is an elongate through-slot 254 dimensioned to accommodate close receipt of the silicone strip assembly 104 therethrough. Through slot 254 can be either on the side for the inlet insert or on the crown for the outlet insert. The through-slot 254 communicates with the internal center cavity 250 of the dome nut 246. Four spaced apart elongate indentations 256 are placed within an external surface of the domed body 248 to avoid rotation of the nut when screwing either the filter or the valve to the thread.

FIGS. 30E through 30H are views showing a third embodiment of the inlet cavity insert assembly employing an alternative dome nut 270. The dome nut 270 has a domed body 248, center cavity 250, and coupling threads 252. A pair of gripping flanges 272 extend from opposite sides of the dome body 248. In the alternative dome nut embodiment, the through-slot 254 is placed at the crown of the nut body as shown. Thus, through slot 254 can be either on the side for the inlet insert or on the crown for the outlet insert. The slot 254 in the FIGS. 30E through 30H is likewise dimensioned for close receipt of the silicone strip assembly 104.

FIGS. 31A through 31C show a filter assembly 258 which couples to the inlet dome nut of FIGS. 30A through 30D or the alternative inlet dome nut of FIGS. 20E through 30H to complete the alternative post-cure inlet cavity insert assembly. The filter assembly 258 includes a hex nut body 260 having an internal chamber 262 and an externally threaded coupling post 264. The chamber 262 is sized to seat a porous filter member 266 therein. The body 260 has an opening 261 communicating with the chamber 262 to admit air into the body 260, through the filter member 266 therein, and out of an axial passage 263 through post 264. The post 264 threads into the dome nut 246 or 270.

FIGS. 32A through 32D show an embodiment of an outlet cavity insert assembly dome nut 268 in which the indentations 256 in the dome body are deployed as in the embodiment of inlet dome nut embodiment FIGS. 30A through 30D while the crown placement of slot 254 is similar to the inlet dome nut of FIGS. 30E through 30H. The outlet dome nut 268 has an internal chamber 250, coupling threads 252 and through-slot 254 sized to admit closely the silicone strip assembly 104.

Referring to FIGS. 33A through 33C, a second embodiment of an outlet valve assembly 272 is shown. The valve assembly 272 is an alternative to the valve assembly 204. Valve assembly 272 is a one-way ball valve including a hexagonal valve body 274, a coupling nut 276, an axial bore 278 extending through the body 274 to an outlet bore 290, a compression spring 284 seated within body 274, a threaded stop plug 282 coupled into threads 280 within bore 278, and a ball valve 286 seated within the housing 274 at the shoulder separating the axial bore 278 with the outlet passage 290. The housing 274 has an externally threaded coupling neck 288 at a forward end adapted to couple into the outlet dome nut shown in FIGS. 32A and 32B in a post-cure assembly procedure. A one-way ball valve of the type shown is commercially available, such as from Beswick Engineering located in Greenland, N.H., U.S.A. The ball valve 286 under bias from spring 284 seats against shoulder 227. The compression pressure is set by threaded insertion of plug 282 into the axial bore 278. Air pressure from the tire cavity impinges the ball 286 and forces the ball valve against shoulder 287 so long as the tire cavity pressure is at or exceeds a pressure threshold. When the pressure from the tire cavity falls below the threshold, upstream air pressure from air forced along air passageway 238 pressures on the ball 286, forcing the ball 286 away from the shoulder 227 and allowing air to flow from passageway 290, along the bore 278, out of housing 274, and into the tire cavity.

FIGS. 34A and 34B show detail views of a dome nut cap 268 for use in the dome nut system. The cap 292 includes an axial through-passageway sized and configured for receipt of an end of silicone strip assembly 104; a threaded cylindrical body 296, and a circular cap head 298. FIGS. 35A and 35B show details of the hollow needle component or punch 300 for the dome nut system embodiment. The punch 300 includes a cylindrical body 402, a conical punch nose portion 304, a blind, rearwardly open axial bore 306, and a coupling shank 308 having external threads 310.

FIGS. 36A through 36B show in sequence the deployment of the dome nut inlet cavity insert assembly into a pre-cure tire. The silicone strip assembly 104 of the green tire extends through the chafer passageway as previously described with a surplus assembly end portion 108 protruding from the inlet cavity 132. The inlet dome nut embodiment of FIG. 30A through 30D is inverted and press inserted into the cavity 132 after free end portion 108 of the silicone strip assembly 104 is routed through the slot 254 of the dome nut 246 and free of the dome nut cavity 250. A void around the inlet dome nut 248 is filled with a chafer compound 312. The cap 292 threads into the inserted and seated dome nut 248 with free end portion 108 projected through the slit 294 of the cap 292 in anticipation of tire cure.

FIGS. 37A through 37F show in sequence the deployment of the dome nut embodiment of the outlet cavity insert assembly into a tire. The outlet free end 106 of the silicone strip assembly 104 is inserted through the crown slit 254 of an inverted outlet dome nut 268 (FIGS. 32A through 32D) and routed into the axial bore 306 of the needle component 300. The component 300 and dome nut 268 are then coupled (FIG.

37B) and inserted through the outlet cavity 134 as shown in FIG. 37C, with the needle conical tip forcing through the inner side of the tire sidewall defining cavity 20. The needle component 300 projects into the tire cavity 20 as shown. The needle component 300 is removed and replaced with the cap 292, with the free end 106 of the strip assembly 104 extending through the cap slot as shown in FIGS. 37D and 37E. From the outward side of the cavity 134, a plug 314 composed of chafer material is inserted into the cavity 134 to fill the cavity for the cure procedure.

FIG. 38 shows a post-cure tire with the protective caps 292 being removed from both the inlet and outlet dome nuts 246, 268 respectively. The silicone strip assembly 104 is removed from the tire sidewall inlet cavity 132, leaving the vacated air passageway 238 enclosed within the chafer tire component 28 and extending between the inlet and outlet cavities 132, 134. FIG. 39 shows the filter assembly 258 threaded into the inlet dome nut 246. Air from outside of the tire accordingly follows a path through the filter 266, the dome nut 246, and into the air passageway 238. FIG. 40 shows the one-way valve assembly 272 previously described threaded onto the outlet dome nut 268 and positioned to reside and project into the tire cavity 20. FIG. 41 shows the post-cure second embodiment of the tire assembly with the chafer enclosed air passageway extending 180 degrees between the inlet cavity insert assembly 258 and the outlet cavity insert assembly 272.

FIGS. 42A and 42B show the location of the inlet dome nut 246 and filter assembly 258 within the chafer 28 at a lower region of sidewall 14. At such a location, the inlet assembly is located radially above the rim flange 38 so that damage to the assembly from the rim flange is avoided. FIGS. 43A and 43B show the location of the outlet dome nut 268 and valve assembly 272 connected and located within the chafer 28 at a lower region of sidewall 14, radially above rim flange 38.

FIG. 44 shows the air maintenance assembly 42 in the post-cure tire 12 in operation and rolling against the ground surface 316. The air maintenance assembly 42 represents a peristaltic air pump system in which a compressible air passageway 238 progressively pumps air along the passageway from the inlet to the outlet and there to the tire cavity as required to maintain internal tire cavity pressure at a required level. As will be appreciated from FIG. 44, the inlet assembly 258 and the outlet assembly 272 are positioned generally 180 degrees apart, separated by the internal chafer air passageway 238. The tire rotates in a direction of rotation indicated, causing a footprint to be formed against the ground surface 316. A compressive force 318 is directed into the tire from the footprint and acts to flatten a segment of the air passageway 238 opposite the footprint as shown at 320. Flattening of the segment of the passageway 238 forces air from the segment along internal passageway 238 in the direction 322, toward the outlet assembly 272.

As the tire continues to rotate in the direction indicated along the ground surface 316, the air passageway 238 within the chafer component will be sequentially flattened or squeezed opposite the tire footprint segment by segment in direction 322 opposite to the direction of tire rotation. The sequential flattening of the air passageway 238 segment by segment causes evacuated air from the flattened segments to be pumped to the outlet assembly 272. When the air flow pressure is sufficient against the outlet valving mechanism, whether embodied as the ball valve (FIGS. 33A, 33B, 33C), the membrane valve (FIGS. 17A, 17B), the Lee valve (FIGS. 16A, 16B) or other known substitute valving mechanisms, the valve will open and allow air to flow through the outlet assembly 272 to the tire cavity 20. Air exiting the outlet assembly

272 is routed to the tire cavity 20 and serves to re-inflate the tire to a desired pressure level.

With the tire rotating in direction 322, flattened tube segments are sequentially refilled by air flowing into the filtered inlet assembly 258 along the passageway 238. The inflow of air from the inlet assembly 258 continues until the outlet assembly 272 passes the tire footprint. When the tire rotates further, the inlet assembly 258 will eventually pass the tire footprint against ground surface 316, and airflow resumes to the outlet assembly 272 along the passageway

The above-described cycle is then repeated for each tire revolution, half of each rotation resulting in pumped air going to the tire cavity and half of the rotation the pumped air is directed back out the inlet assembly filter. It will be appreciated that while the direction of rotation is indicated, the subject tire assembly and its peristaltic pump assembly 42 will function in like manner in a (clockwise) reverse direction of rotation. The peristaltic pump is accordingly bi-directional and equally functional with the tire assembly moving in a forward or a reverse direction of rotation.

The location of the peristaltic pump, air maintenance assembly 42 will be understood from FIGS. 42A, 42B, 43A, 43B and 44. In the chafer component, the air passageway 238 is in a high flex region of the tire which causes a requisite flattening pressure from the tire rolling against ground surface 316 to be applied to passageway 238. The air maintenance passageway 238 is integrated into and enclosed by the chafer tire component to prevent air leakage that would otherwise degrade the operational efficiency of the pump. Other tire components having high-flex regions may alternatively employed for location of the air maintenance assembly 42 if so desired. For example, without intent to delimit such alternative components and locations, the assembly 42 may be incorporated at a more radially outward location in the tire sidewall 14. The passageway 238 would, in similar manner to that described previously, be deployed within a sidewall ply component during green tire build.

Pursuant to the foregoing, it will be appreciated that a method of constructing a tire having an associate air maintenance pumping assembly results. The method includes: constructing an elongate strip core 58; encasing the strip core 58 into a containment within an uncured flexible tire component (preferably but not necessarily chafer strip 70), the strip core extending between an air inlet cavity or cavity 132 and an air outlet cavity or cavity 134 in the flexible tire component; building on a tire building drum 116 a green tire carcass from tire components including the flexible tire component and encased strip core; curing the green tire carcass into a cured finished tire 10 including the flexible tire component 170 containing the strip core 58; removing the encased strip core 58 from the cured flexible tire component to leave within the flexible tire component a substantially unobstructed air passageway 238; and inserting a post-cure air inlet assembly 240 or 258 or 272 into the air inlet cavity 132 and a post-cure air inlet assembly 198 or 210 into the air outlet cavity 134.

It will further be appreciated in the preferred method that the strip core 58 (or 104 as encased by rubber gum strip 92) is longitudinally removed by a free end from the cured flexible tire component, chafer strip 70, generally tangential to the tire carcass, by means of drawing on the free end 108 of the strip core and extending the air outlet assembly 198, 210 inward through a tire sidewall by means of utilization of punch 138 into communication with the tire cavity 20.

The preferred method further includes inserting a pre-cure temporary air inlet assembly 170 into the air inlet cavity 132 prior to curing the green tire carcass; and inserting a temporary air outlet assembly 136 into the air outlet cavity 134 prior

15

to curing the green tire carcass; and removing the temporary air inlet assembly **170** and the temporary air outlet assembly **136** after curing the green tire carcass, to be replaced by the permanent post-cure inlet assembly (**240** or **258** or **272**) and post-cure permanent outlet assembly. The temporary inserts at the inlet and outlet positions serve to keep the cavities **132**, **134** open during tire cure for eventual post-cure insertion of the permanent inlet and outlet cavity assemblies.

The method also includes encasing the strip core into a containment within the uncured flexible tire component by forming, preferably by an extrusion, a channel or tube **80** into the uncured flexible tire component (chafer strip **70**) defined by channel sidewalls **82**, **84** and a channel bottom wall **86**; inserting the strip core **104** into the channel; and collapsing a flexible channel sidewall or flap **114** to enclose the sidewall **82** over the strip core **104**. The uncured flexible tire component is preferably a tire chafer component but other alternative tire components may be substituted so long as the tire components exhibit sufficiently high flexure during tire rotation to progressively collapse the air passageway **238** in a rolling tire footprint.

It will further be appreciated that the temporary cavity insert assemblies at the inlet and outlet cavities **132**, **134** provide a connector system that is flexible and multi-purpose. In the air maintenance tire and connector system thus provided, the elongate integral air passageway formed by the silicone strip assembly **104** at the pre-cure tire build stage, and by the vacated air passageway **238** post-removal of the assembly **104** in a post-cure procedure. The connector assembly represented by the connectors in FIGS. **14A** through **14D** (outlet core assembly **136**) and in FIGS. **15A** through **15C** (inlet core assembly **170**) each include a hollow body having a central chamber, a protruding coupling funnel housing end extending from the hollow body to couple into the air passageway, and a through-channel extending through the funnel housing end to the central chamber. The connector assembly further provides, in the outlet core assembly **136**, a dependant coupling post **146** extending from the hollow body. The coupling post **146** an axial length sufficient to project inward from the cavity **134** through a tire wall thickness to the tire central cavity **20**. The axial air conducting through-bore extends through the coupling post **146** from the hollow housing central cavity **148** to a remote end of the coupling post positioned within the tire central cavity **20**. The remote end of the coupling post **146** is operative for sequential alternative attachment to: the punch device **138** for penetrating through the tire wall thickness to the tire central cavity **20** in post-tire build, pre-tire cure procedure in which the assembly **136** is inserted into its cavity **134**; a capping nut **140** attaching to the remote end of the coupling post **146** operative to enclose the axial post through-bore throughout the tire curing procedure; and a valve device attaching post-curing of the tire to the remote end of the coupling post, the valve device such as at numeral **204** operative to regulate air flow between the hollow housing into the tire cavity.

The connector system described and shown in the dome nut embodiment of FIGS. **30A** through **30G**, **31A** through **31C**, **32A** through **32D** and **33** through **44** (inclusive) includes a hollow dome-shaped nut body **246**, **268**, **270** having a central chamber **250** within the nut body opening to an outward body side; and a through-channel **254** extending through the nut body operative to conduct air flow communication between the integral air passageway **238** within the chafer **28** (or other flexible tire component selected) and the central chamber **250** of the nut body. A hollow dome-shaped inlet nut **246**, **270** is seated within the inlet cavity **132** and a hollow dome-shaped outlet nut **268** within the outlet cavity **134**, with the outlet and

16

inlet nuts oriented within respective cavities to face in opposite directions. The inlet nut **268** or **270** couples to air inlet filter device **258** (an air inlet device) for conducting air external to the tire carcass into the inlet nut central chamber **250**; and the outlet nut **268** couples to outlet valve assembly **272** (a valve device) positioned within the tire cavity **20**. The valve device **272** is operative to regulate a flow of air from the outlet dome nut body **248** to the tire cavity **20**.

It will further be noted that the connector and tire assembly utilizes and includes the removable elongate silicone strip assembly **104** to form the air passageway **238** during a pre-cure build of the tire carcass as described. As explained, the strip assembly is withdrawn post-cure from the air passageway **238** of the tire carcass. The through-channel **254** in the nut bodies of the inlet nut and the outlet nut have a cross-sectional configuration to closely admit a respective opposite free end **106**, **108** of the core strip therethrough. The through-channel **254** in the nut bodies may be alternatively located at the crown apex region or in a sidewall location.

The chafer component strip **70**, as will be appreciated from FIGS. **6** through **11** inclusive, represents a flexible tire component strip forming a portion of the tire carcass **12**. The tire component strip in the form of chafer strip **70** provides the channel **90** within an upper surface defined by opposed strip lip portions **82**, **84** and a channel bottom wall **86**; the air passageway **238** formed within the flexible chafer tire component **70** extending between the air inlet cavity **132** and the air outlet **134** cavity in at least a partial circumferential, and preferably a 180 degree, path around the tire carcass **12**. The elongate passageway-shaping strip assembly **104** occupies and forms the air passageway **238** of the flexible chafer tire component **70** during green tire build and tire cure. The passageway-shaping, silicone strip assembly **104** is operative to form and maintain the air passageway **238** to a desired cross-sectional configuration which replicates the cross-sectional configuration of the silicone strip assembly **104**.

The passageway-shaping, silicone strip assembly **104** is removable from the air passageway **238** in a post-cure procedure. The free end portions **106**, **108** are accessible at the air inlet and air outlet cavities, respectively, whereby the silicone strip assembly **104** may be removed by an axial withdrawal force application to the free end portion **106** or **108** of the silicone strip assembly **104**.

It will be noted in FIGS. **5** and **10A** through **10C**, that the passageway-shaping strip assembly **104** has a generally elliptical cross-sectional configuration and is configured having a silicone core **58** encased by a sheath **92** composed of a release material such as a rubber composition. The flexible chafer tire component **70** increases side-to side (the axial direction in the tire carcass **12**) in sectional thickness from the radially outward region **72** to the radially inward region **88**. The channel **90** which becomes air passageway **238** resides within the radially inward, thicker region **88**. The channel **90** is formed to extend into region **88**, angling radially inward toward the radially outward region **72** as seen in FIGS. **10A** through **10C** at an angle θ within a preferred range -20 to $+20$ degrees.

With reference to FIG. **26**, the preferred method of extracting the elongate strip assembly **104** from the air passageway defined by the assembly **104** occurs in a post-cure procedure. The assembly **104** is extracted longitudinally from occupancy within the flexible tire component (chafer **28**), whereby defining the air passageway in **238** within the chafer component by the space previously occupied by the elongate strip assembly **104**. The elongate strip free end portion **108** is accessible at the air inlet cavity **132** and the free end portion **106** at the air outlet cavity **134**. The elongate strip assembly **104** is moved and extracted tangentially end to end relative to the tire car-

17

cass from the air inlet cavity **132** by a withdrawal force applied to the elongate strip free end **108**. Alternatively, the assembly **104** may be extracted from the outlet opening **134** by means of free end **106**. Application of the withdrawal force may be in the form of a tensile force applied to the free end portion **108** of the elongate strip assembly **104** alone or in conjunction with other extraction techniques. For example, without restriction intended, an extraction pneumatic system may be deployed to push the assembly **104** from the chafer channel. As will be understood, a pneumatic system (not shown) of known type may consist of an air blow gun on to which a nozzle is attached. The nozzle may be configured to thread into the outlet dome nut **268** (FIGS. **32A** through **32D**) cured into the outlet cavity **134**. The gun delivers a volume of pressurized air into the passageway **238**, forcing the silicone strip assembly **104** tangential to the tire carcass and out the inlet cavity **132**. A lubricant such as a mixture of water and detergent may be injected along the silicone strip assembly to assist in achieving its extraction. Once the silicone strip **104** is withdrawn, an air inlet device as explained is inserted into the air inlet cavity **132** and an air outlet device into the air outlet cavity **134** in air flow communication with opposite ends of the defined air passageway **238**.

Variations in the present invention are possible in light of the description of it provided herein. While certain representative embodiments and details have been shown for the purpose of illustrating the subject invention, it will be apparent to those skilled in this art that various changes and modifications can be made therein without departing from the scope of the subject invention. It is, therefore, to be understood that changes can be made in the particular embodiments described which will be within the full intended scope of the invention as defined by the following appended claims.

What is claimed is:

1. An air maintenance uncured tire and connector system comprising:
 - an uncured tire carcass;
 - an elongate integral air passageway contained within a flexible tire uncured component of the uncured tire carcass, the air passageway extending between an air inlet and an air outlet cavity in the flexible tire uncured component, the air passageway extending at least a partial circumferential path around the uncured tire carcass;
 - an elongate passageway-shaping strip core residing within the air passageway having a free end extending into a first of the cavities;
 - a connector assembly inserted within the at least a first of the cavities, the connector assembly including a hollow body having a central chamber, a protruding funnel housing portion extending from the hollow body into the uncured component and within an end of the air passageway, and a through-channel extending through the funnel housing portion to the central chamber, the through-channel having a sectional profile accommodating receipt of the free end of the strip core therein.
2. The air maintenance tire and connector system of claim 1, wherein the flexible tire component comprises a pre-cure installed component of the tire carcass.
3. The air maintenance tire and connector system of claim 1, wherein the hollow body is formed by mating hollow body components.
4. The air maintenance tire and connector system of claim 3, wherein the mating hollow body components are at least partially composed of metal.
5. The air maintenance tire and connector system of claim 4, wherein the hollow body is substantially ovoid in configuration.

18

6. The air maintenance tire and connector system of claim 1, wherein the connector assembly further having a dependent coupling post extending from the hollow body, the coupling post having an axial length sufficient to project axially inward from the first cavity through a tire wall thickness to a tire central cavity, the coupling post having an axial through-bore extending from the hollow housing central cavity to a remote end of the coupling post positioned within the tire central cavity.

7. The air maintenance tire and connector system of claim 6, wherein the coupling post at the remote end is operatively reconfigurable as a punch device for penetrating in a pre-cure procedure through the tire wall thickness to the tire central cavity; a capping nut operative to enclose the axial post through-bore; and a valve device operative to regulate air flow between the coupling post axial through-bore into the tire cavity.

8. An air maintenance uncured tire and connector system comprising:

- a tire carcass;
- an elongate passageway-shaping strip core forming an integral air passageway contained within a flexible tire component, the strip core forming the air passageway extending between an air inlet and an air outlet cavity in the flexible tire component, the strip core forming the air passageway extending at least a partial circumferential path around the tire carcass;
- a connector assembly inserted within at least a first of the cavities, the connector assembly including a hollow body having a central chamber, a protruding funnel housing portion extending from the hollow body, and a through-channel extending through the funnel housing portion to the central chamber, the through-channel having a sectional profile accommodating receipt of a free end of the strip core therein;

wherein the connector assembly further having a dependent coupling post extending from the hollow body, the coupling post having an axial length sufficient to project axially inward from the first cavity through a tire wall thickness to a tire central cavity.

9. The air maintenance tire and connector system of claim 8, wherein the coupling post includes an axial through bore extending from the hollow housing central cavity to a remote end of the coupling post within the tire central cavity.

10. The air maintenance tire and connector system of claim 9, wherein the remote end of the coupling post is operative for sequential attachment to a punch device for penetrating through the tire wall thickness to the tire central cavity, a capping nut attaching to the remote end of the coupling post and operative to enclose the axial through-bore; and a valve device attaching to the remote end of the coupling post and operative to regulate air flow between the hollow housing and the tire cavity.

11. The air maintenance tire and connector system of claim 10, wherein the coupling post is internally and externally threaded.

12. The air maintenance tire and connector system of claim 11, wherein further comprising an assembly screw extending through the hollow housing and threading into the coupling post.

13. The air maintenance tire and connector system of claim 12, wherein the punch device comprises a pointed tip portion and an externally threaded coupling shank operatively threaded into the remote end of the coupling post.

14. The air maintenance tire and connector system of claim 13, wherein the capping nut comprises a nut body and an

internally threaded socket operatively threading over the remote end of the coupling post.

* * * * *