



US 20150158353A1

(19) **United States**

(12) **Patent Application Publication**
Hinque et al.

(10) **Pub. No.: US 2015/0158353 A1**

(43) **Pub. Date: Jun. 11, 2015**

(54) **SELF-INFLATING TIRE AND PRESSURE REGULATOR**

Publication Classification

(71) Applicant: **The Goodyear Tire & Rubber Company**, Akron, OH (US)

(51) **Int. Cl.**
B60C 23/12 (2006.01)
B60C 19/00 (2006.01)
B60C 5/12 (2006.01)

(72) Inventors: **Daniel Paul Luc Marie Hinque**, Habay-la-Neuve (BE); **Jeannot Frieden**, Uebersyren (LU); **Anne Therese Peronnet-Paquin**, Luxembourg (LU)

(52) **U.S. Cl.**
CPC . *B60C 23/12* (2013.01); *B60C 5/12* (2013.01); *B60C 19/00* (2013.01)

(21) Appl. No.: **14/546,490**

(57) **ABSTRACT**

(22) Filed: **Nov. 18, 2014**

A self-inflating tire assembly includes an air tube connected to a tire and defining an air passageway, the air tube being composed of a flexible material operative to allow an air tube segment opposite a tire footprint to flatten, closing the passageway, and resiliently unflatten into an original configuration. The air tube is sequentially flattened by the tire footprint in a direction opposite to a tire direction of rotation to pump air along the passageway to a inlet control valve. The inlet control valve regulates the inlet air flow to the air tube and the outlet air flow to the tire cavity.

Related U.S. Application Data

(60) Provisional application No. 61/914,630, filed on Dec. 11, 2013.

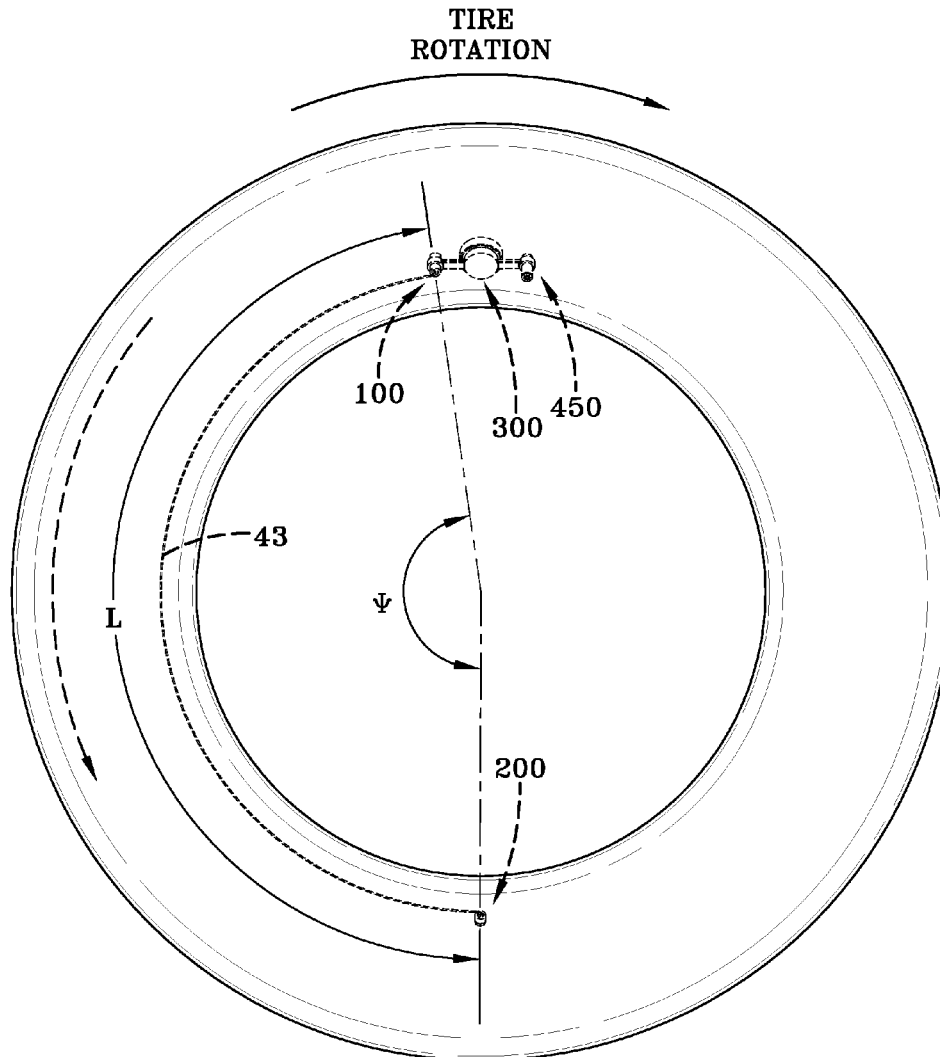

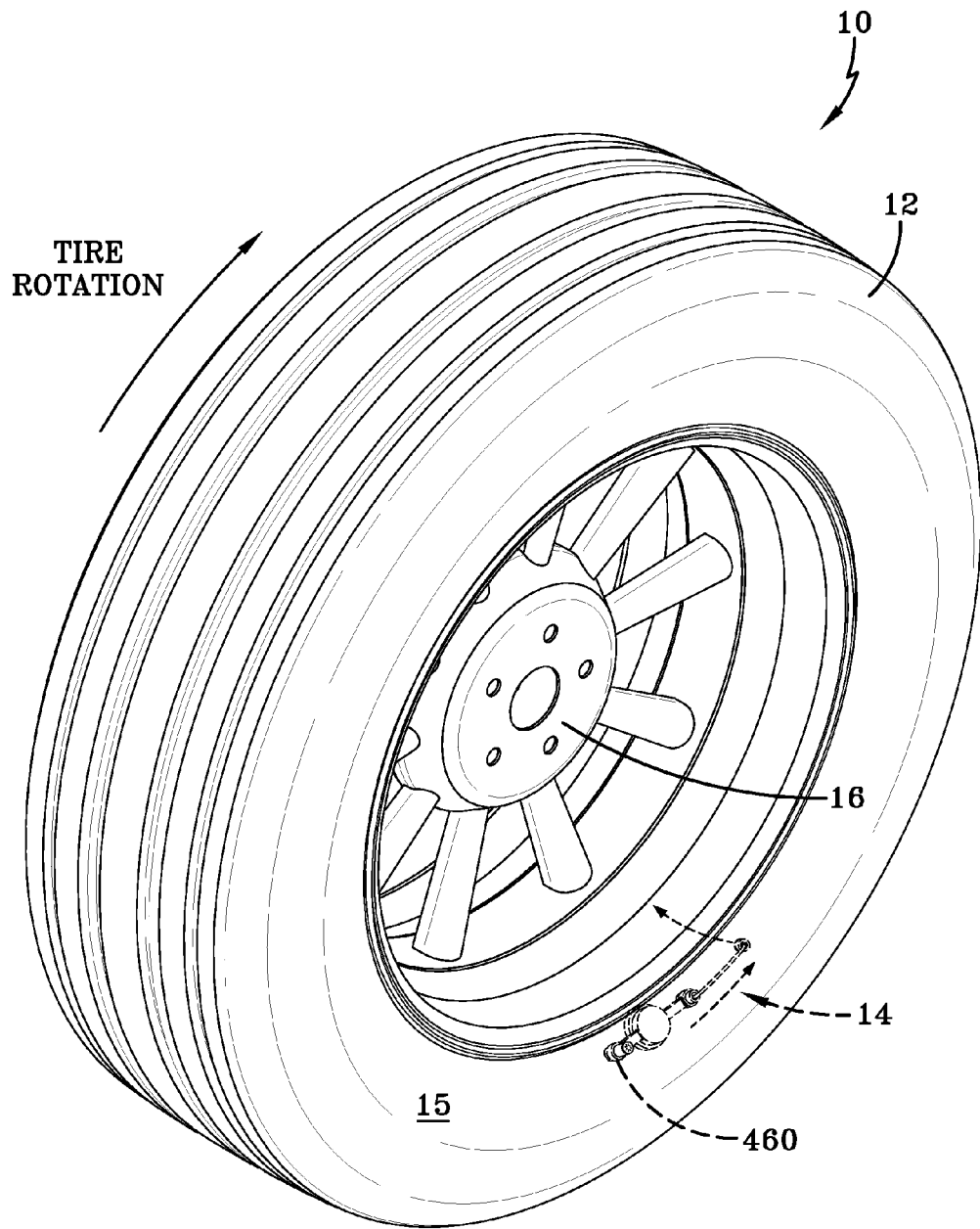

FIG-1

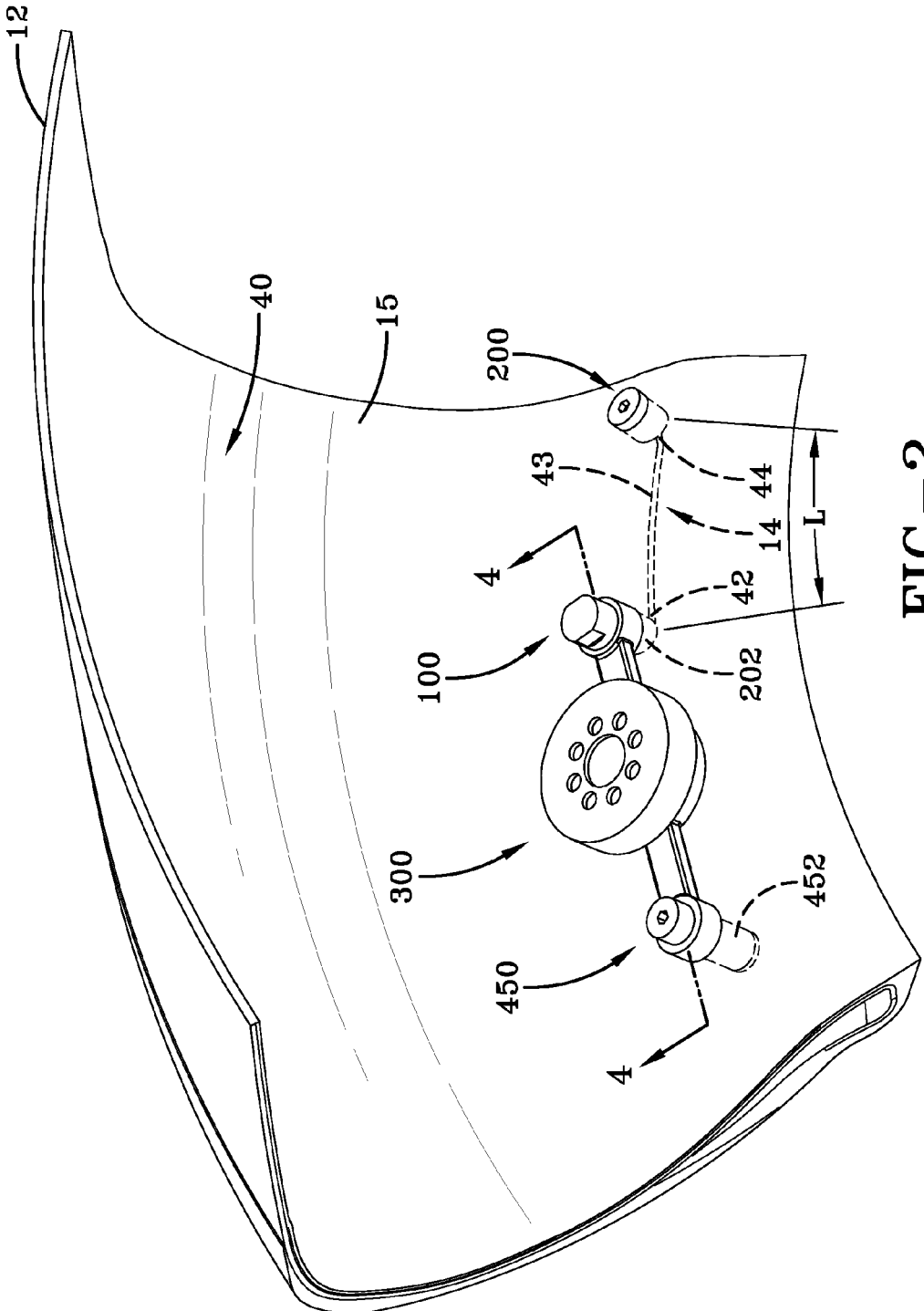

FIG-2

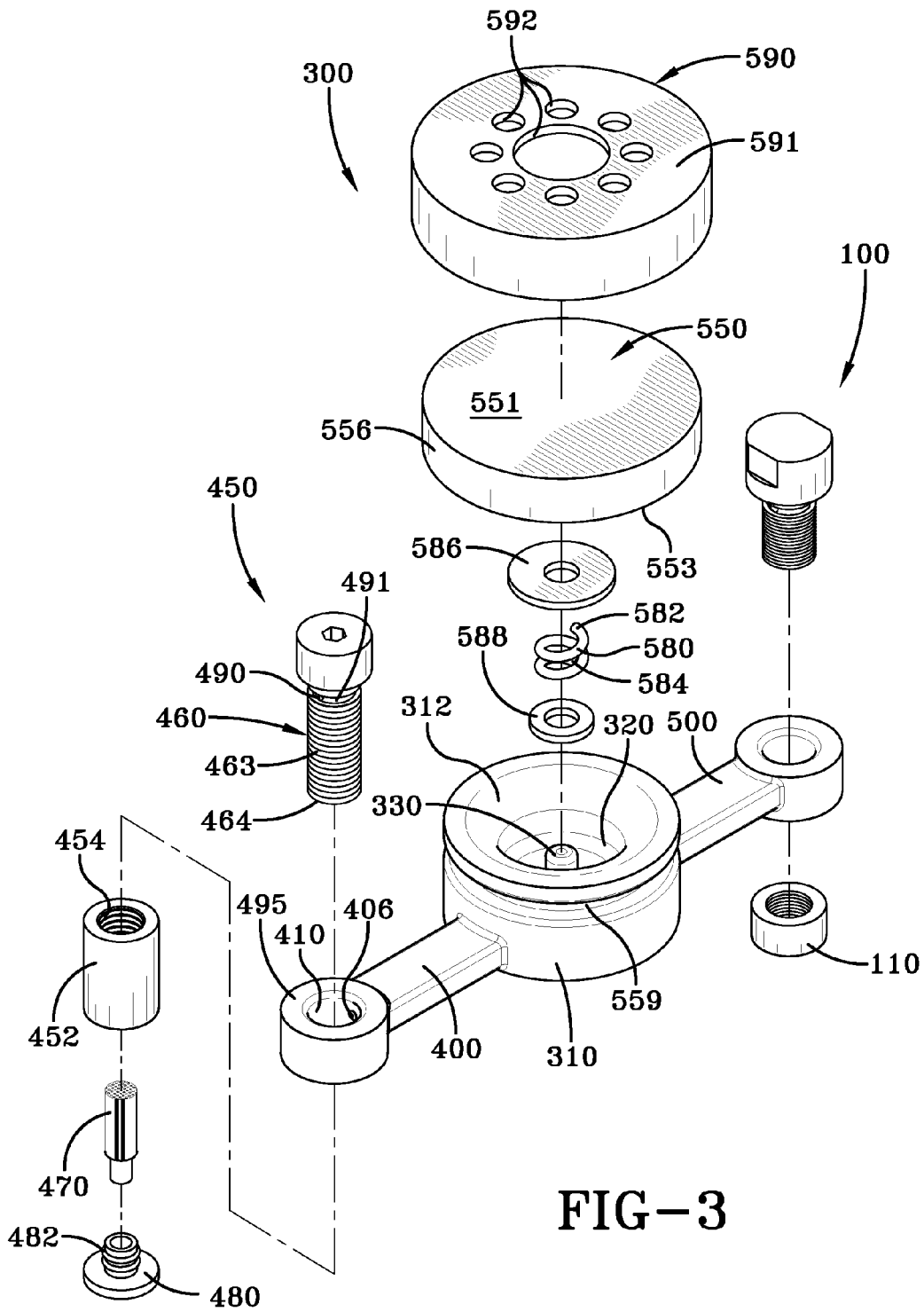

FIG-3

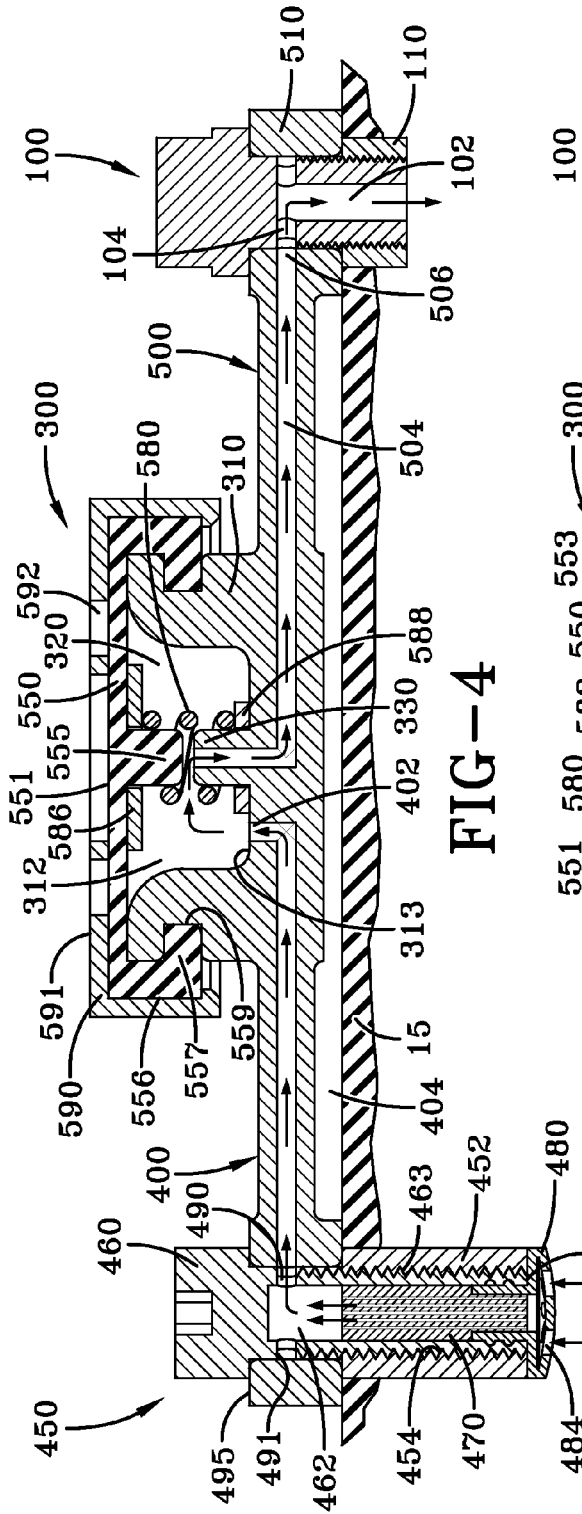

FIG-4

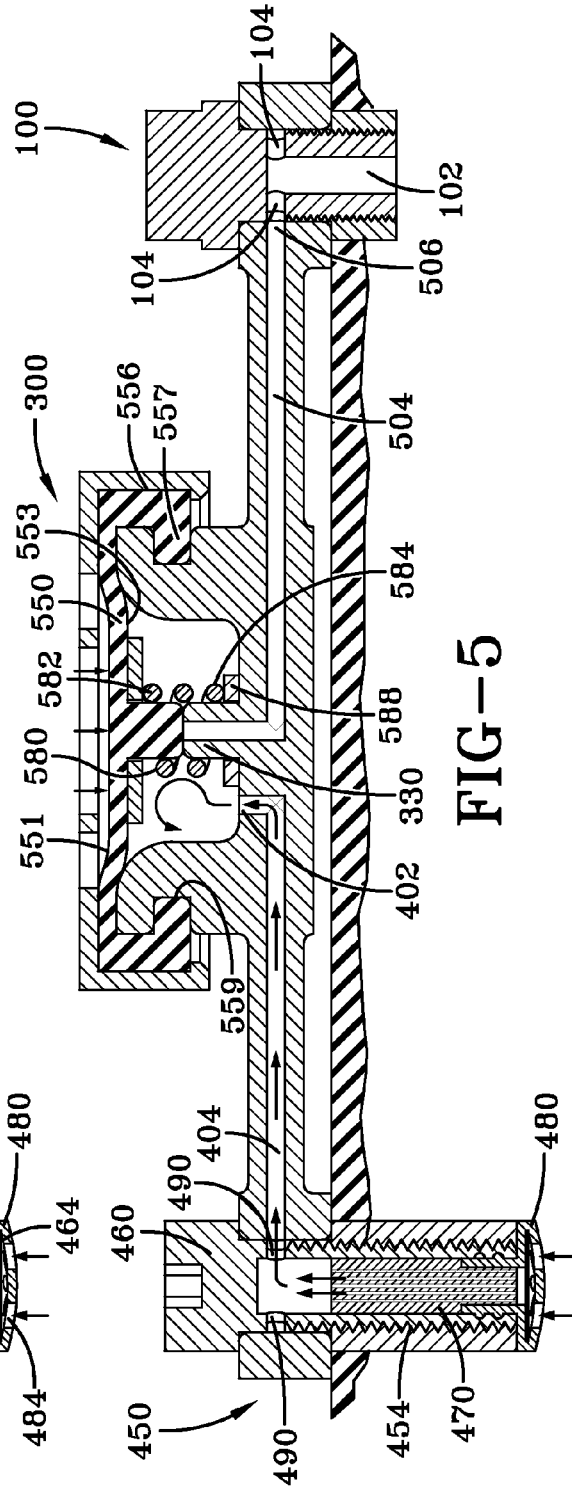

FIG-5

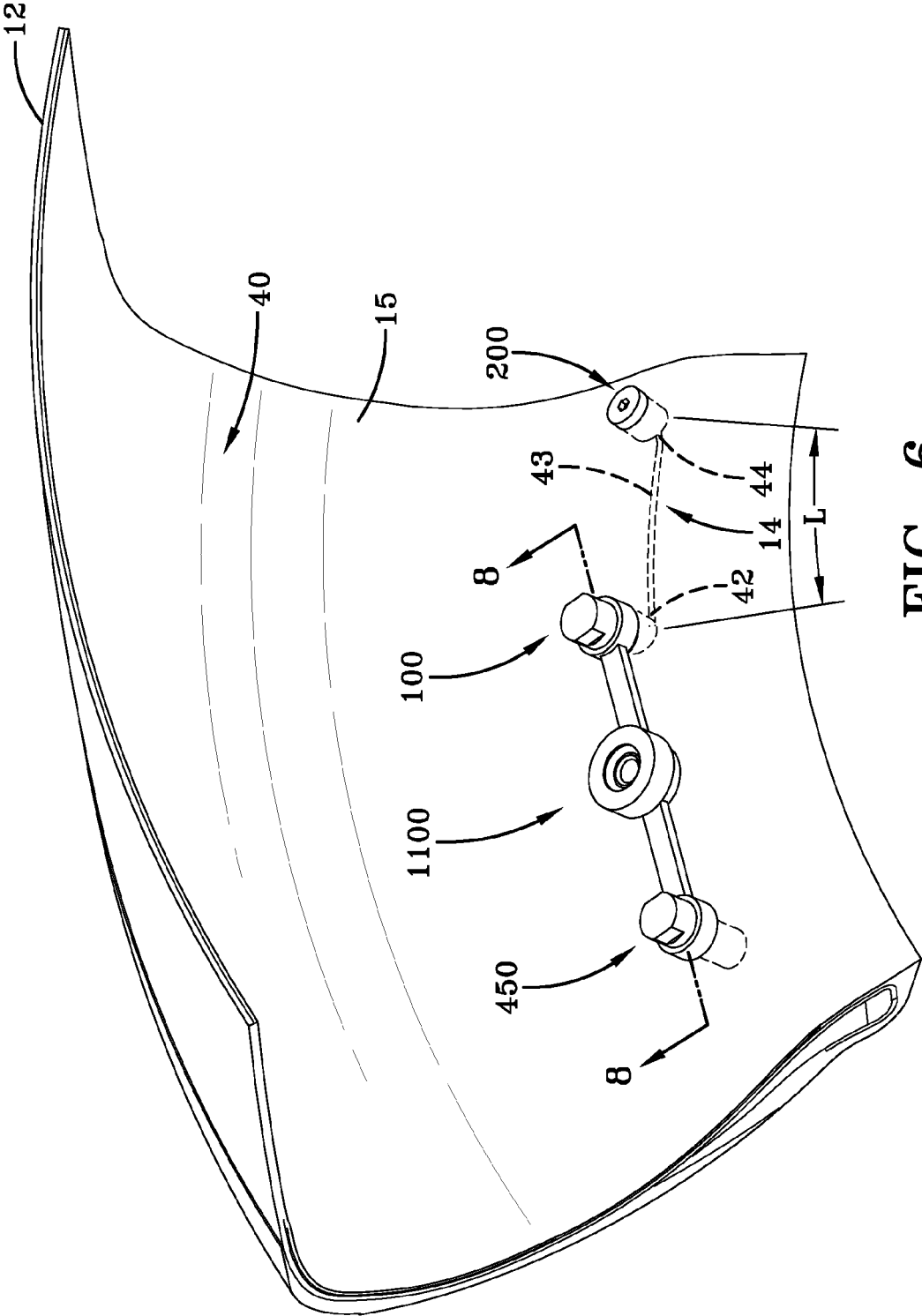

FIG-6

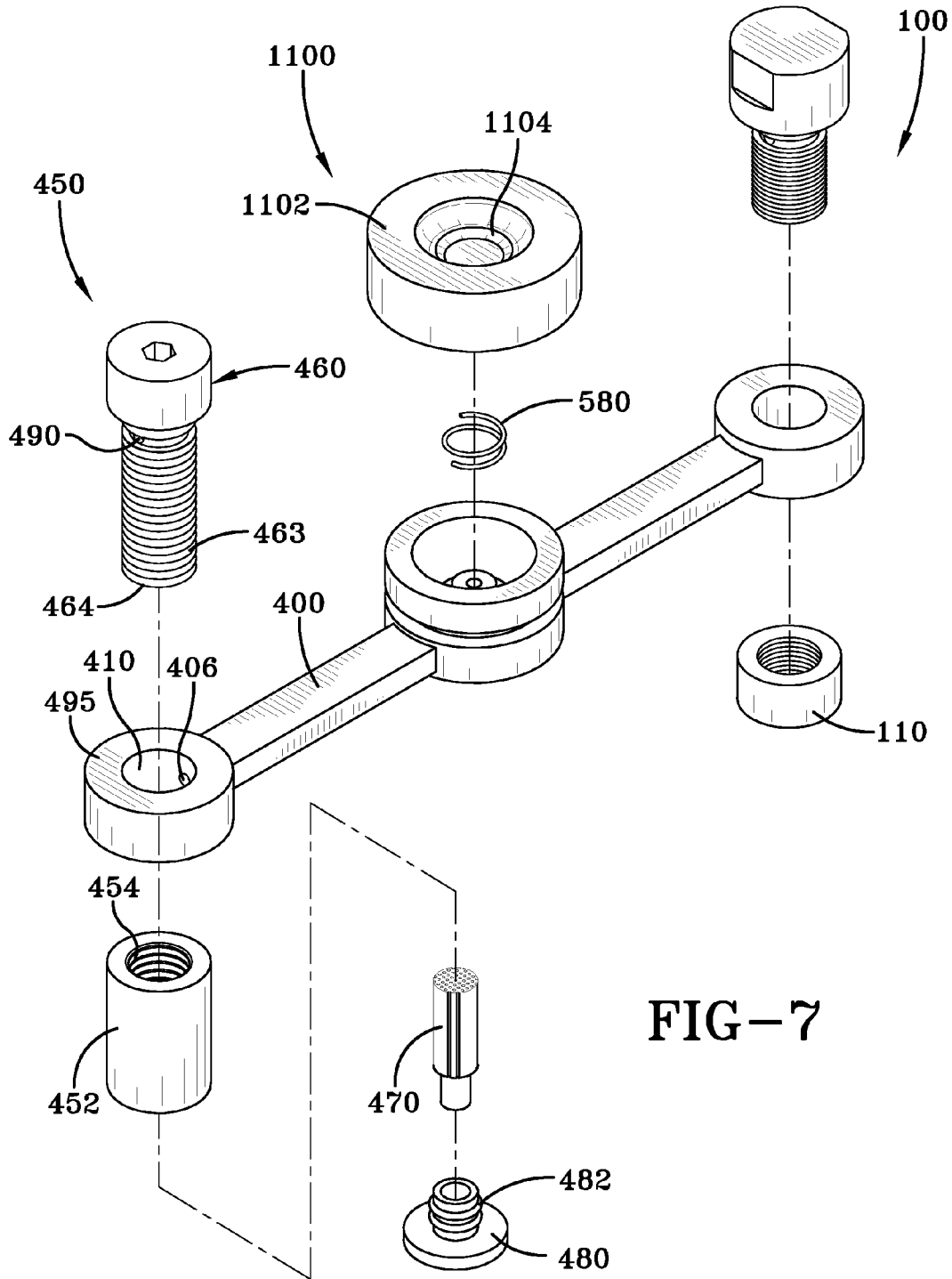
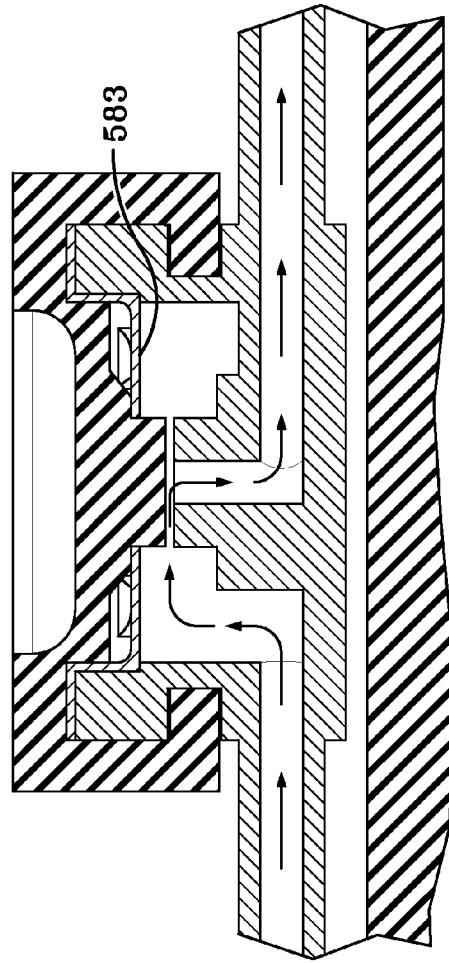
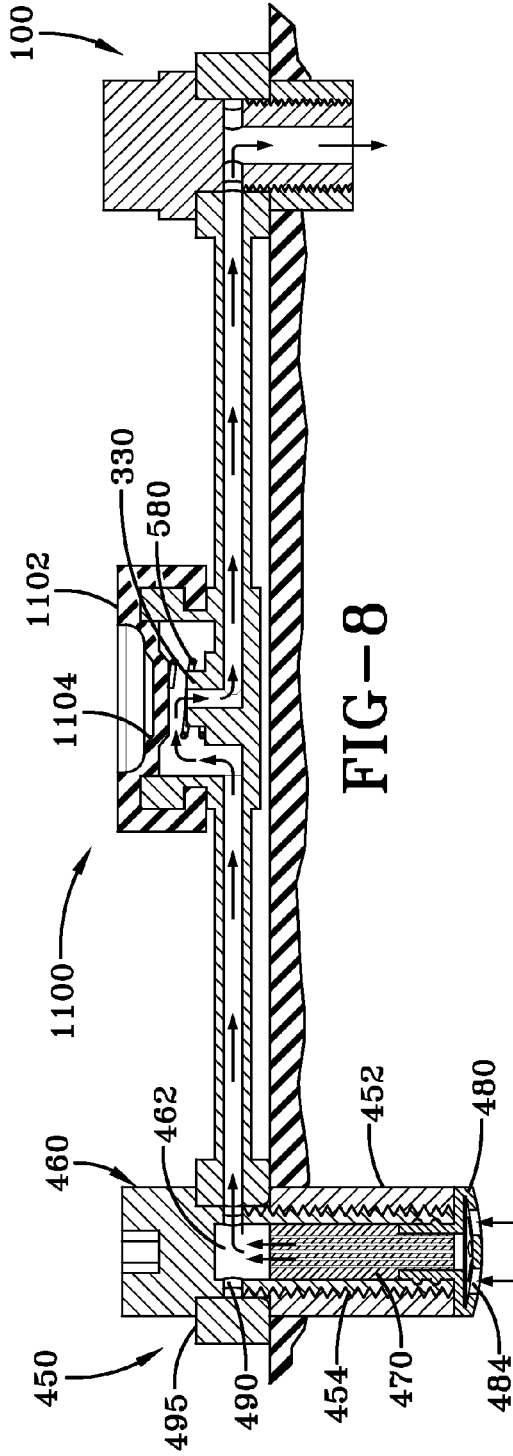
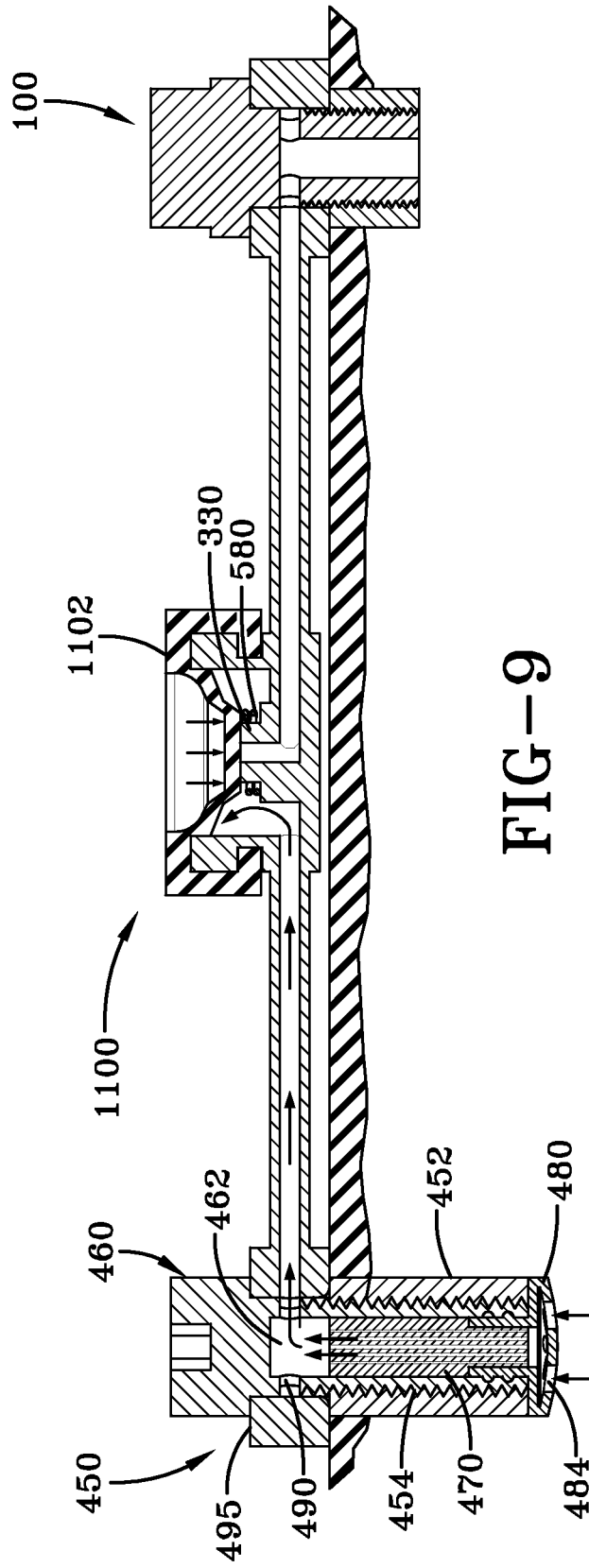

FIG-7





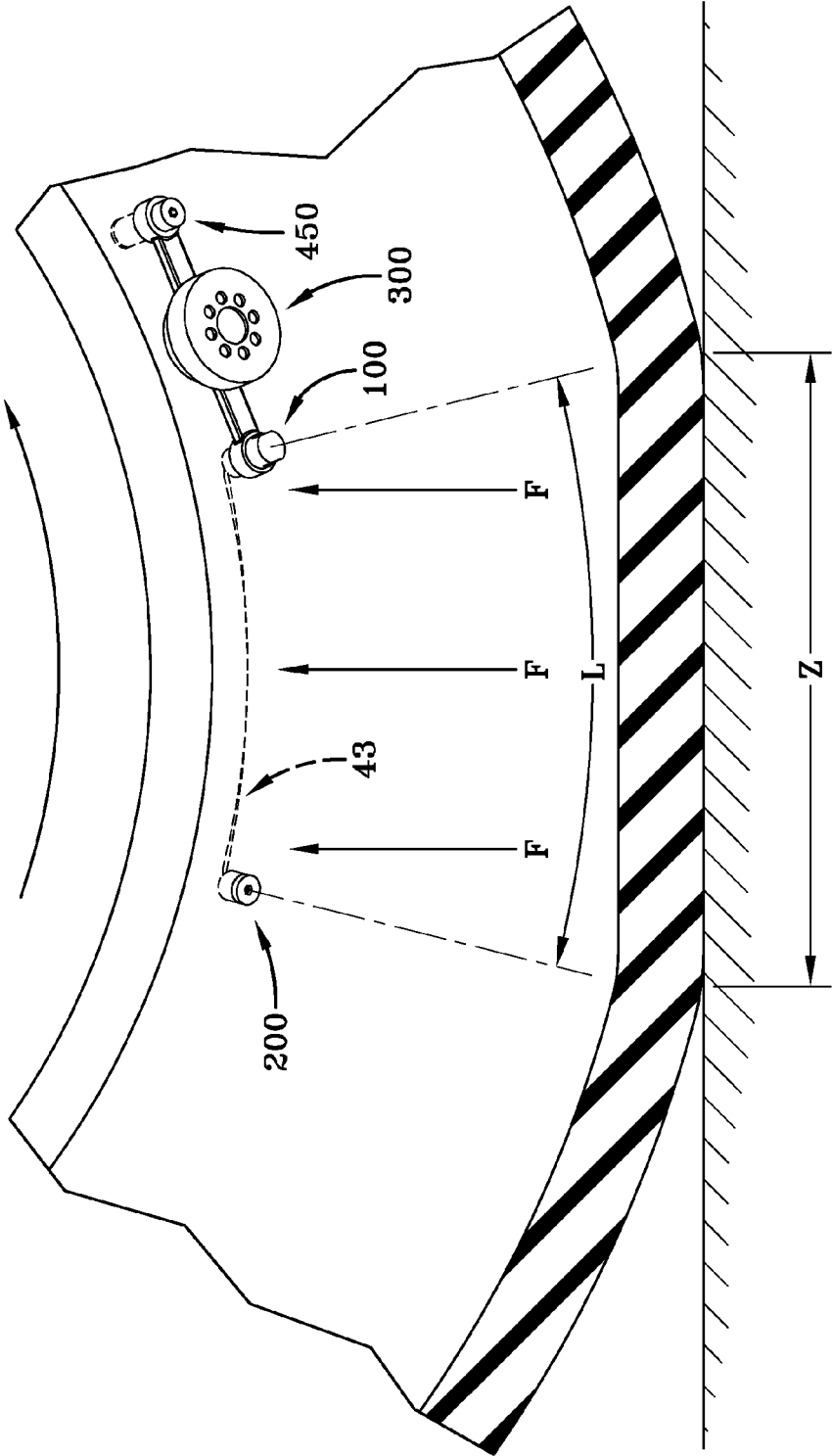

FIG-10

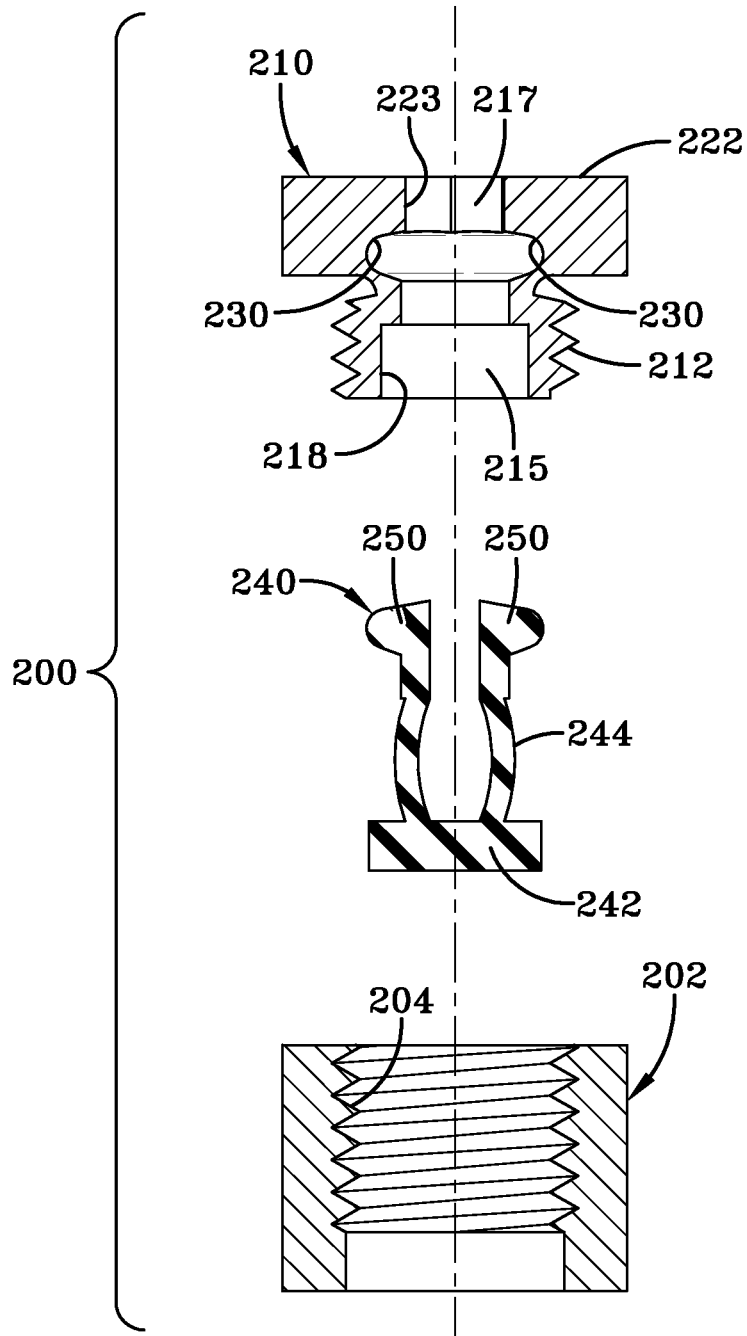

FIG-11

FIG-12A

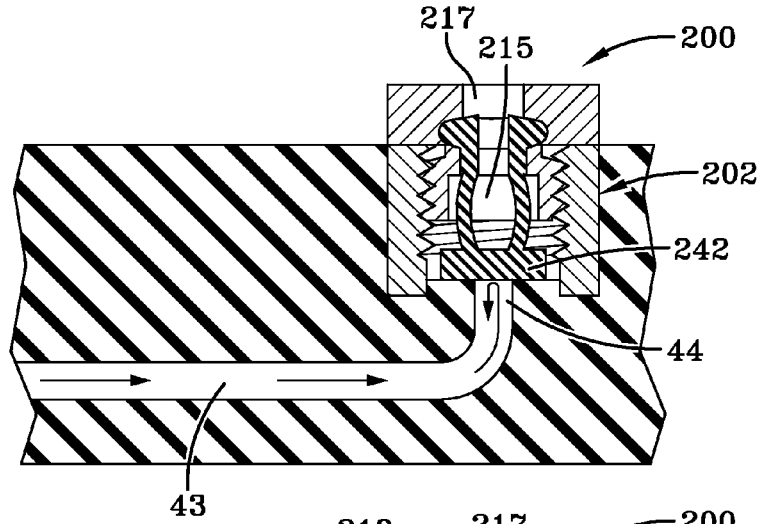

FIG-12B

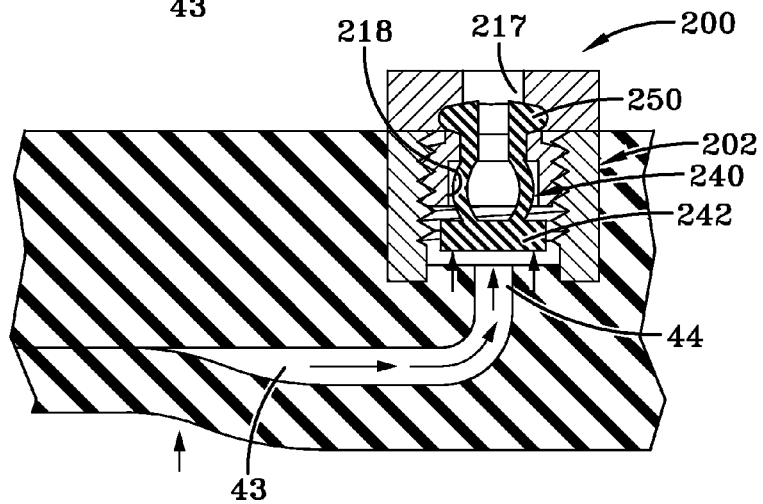

FIG-12C

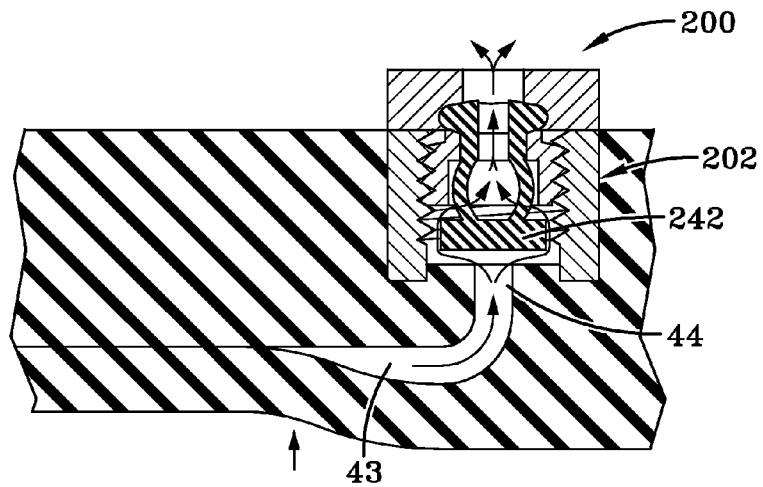
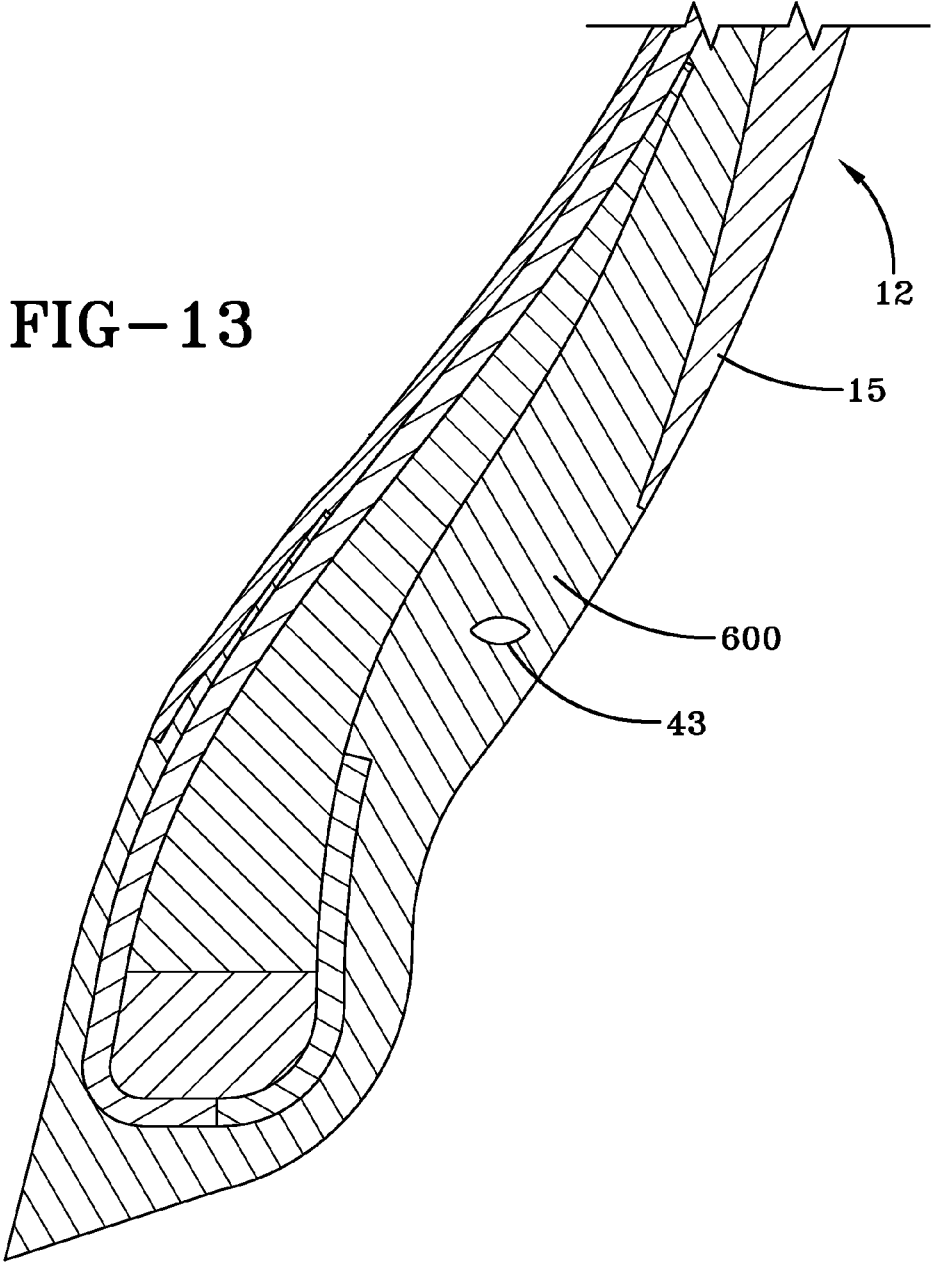

FIG-13



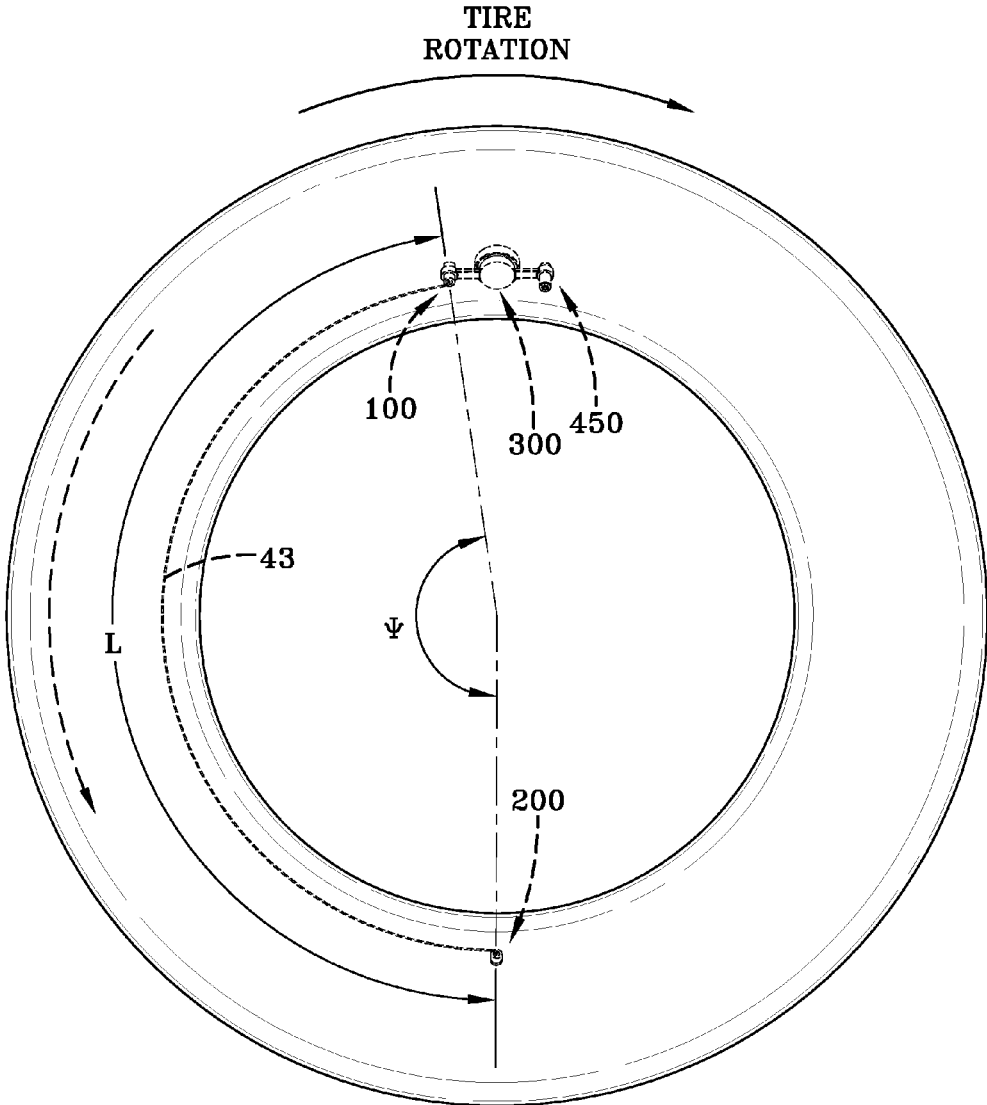

FIG-14

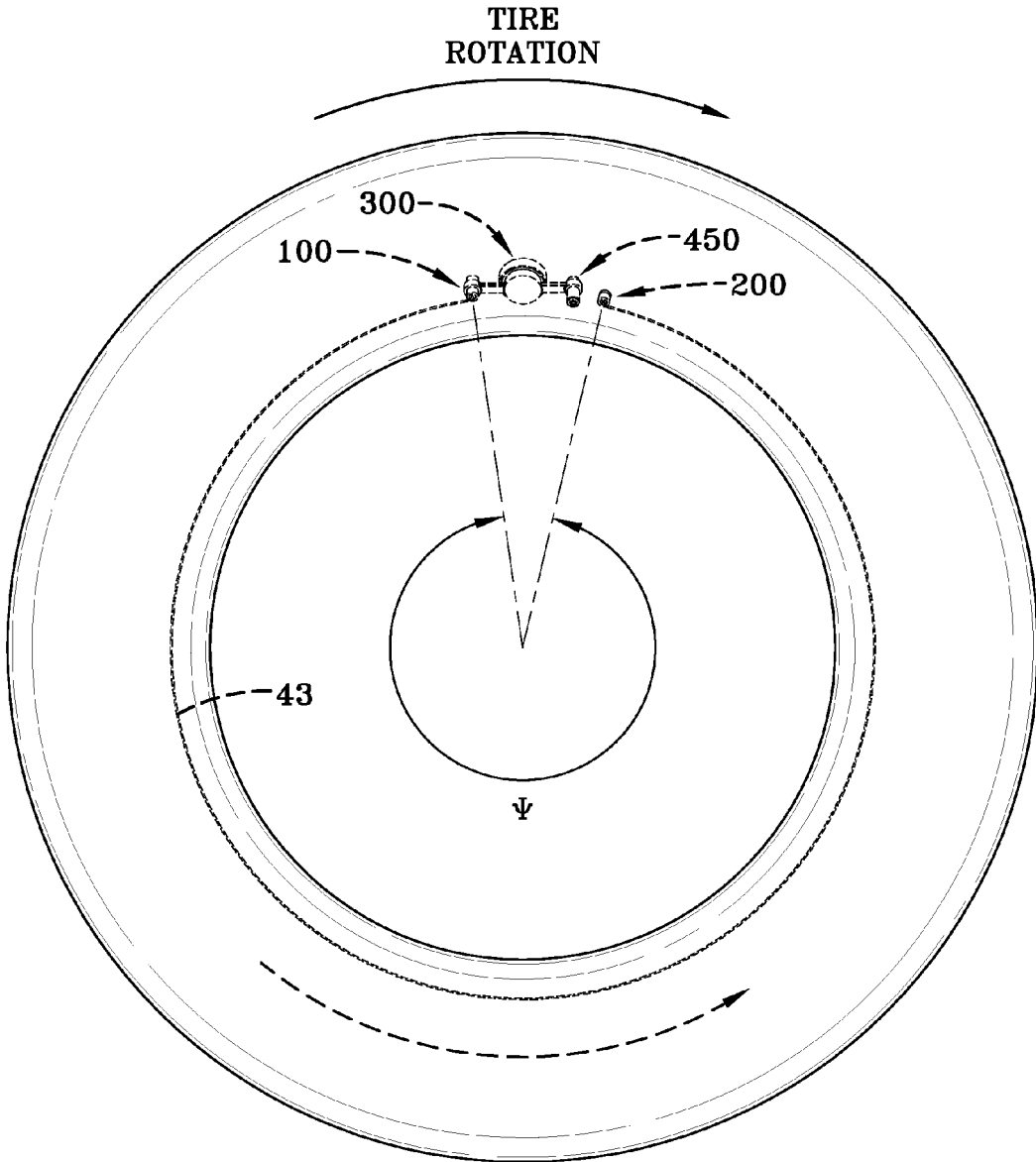

FIG-15

SELF-INFLATING TIRE AND PRESSURE REGULATOR

FIELD OF THE INVENTION

[0001] The invention relates generally to self-inflating tires and, more specifically, to a pump mechanism and pressure regulator for such tires.

BACKGROUND OF THE INVENTION

[0002] Normal air diffusion reduces tire pressure over time. The natural state of tires is under inflated. Accordingly, drivers must repeatedly act to maintain tire pressures or they will see reduced fuel economy, tire life and reduced vehicle braking and handling performance. Tire Pressure Monitoring Systems have been proposed to warn drivers when tire pressure is significantly low. Such systems, however, remain dependent upon the driver taking remedial action when warned to re-inflate a tire to recommended pressure. It is a desirable, therefore, to incorporate a self-inflating feature within a tire that will self-inflate the tire in order to compensate for any reduction in tire pressure over time without the need for driver intervention.

SUMMARY OF THE INVENTION

[0003] The invention provides in a first aspect a self-inflating tire assembly, including a tire mounted to a rim, the tire having a tire cavity, first and second sidewalls extending respectively from first and second tire bead regions to a tire tread region; an air passageway having an inlet end and an outlet end, the air passageway being composed of a flexible material operative to open and close when the tire rotates, wherein the outlet end is in fluid communication with the tire cavity; the inlet control valve having a regulator body having an interior chamber; a pressure membrane being mounted on the inlet control valve to enclose the interior chamber, wherein the pressure membrane has a lower surface that is positioned to open and close the outlet port mounted in the interior chamber, wherein the pressure membrane is in fluid communication with the tire cavity pressure; wherein the body of the inlet control valve has a first and second flexible duct, wherein said first and second flexible ducts each have an internal passageway; wherein the first flexible duct has a first end connected to an inlet filter assembly and a second end is connected to the interior chamber of the inlet control valve, wherein the second flexible duct has a first end connected to the outlet port of the inlet control valve, and a second end in fluid communication with the inlet end of the air passageway.

Definitions

[0004] “Aspect ratio” of the tire means the ratio of its section height (SH) to its section width (SW) multiplied by 100 percent for expression as a percentage.

[0005] “Asymmetric tread” means a tread that has a tread pattern not symmetrical about the center plane or equatorial plane EP of the tire.

[0006] “Axial” and “axially” means lines or directions that are parallel to the axis of rotation of the tire.

[0007] “Chaffer” is a narrow strip of material placed around the outside of a tire bead to protect the cord plies from wearing and cutting against the rim and distribute the flexing above the rim.

[0008] “Circumferential” means lines or directions extending along the perimeter of a surface, perpendicular to the axial direction.

[0009] “Equatorial Centerplane (CP)” means the plane perpendicular to the tire’s axis of rotation and passing through the center of the tread.

[0010] “Footprint” means the contact patch or area of contact of the tire tread with a flat surface at zero speed and under normal load and pressure.

[0011] “Inboard side” means the side of the tire nearest the vehicle when the tire is mounted on a wheel and the wheel is mounted on the vehicle.

[0012] “Lateral” means an axial direction.

[0013] “Lateral edges” means a line tangent to the axially outermost tread contact patch or footprint as measured under normal load and tire inflation, the lines being parallel to the equatorial centerplane.

[0014] “Net contact area” means the total area of ground contacting tread elements between the lateral edges around the entire circumference of the tread divided by the gross area of the entire tread between the lateral edges.

[0015] “Non-directional tread” means a tread that has no preferred direction of forward travel and is not required to be positioned on a vehicle in a specific wheel position or positions to ensure that the tread pattern is aligned with the preferred direction of travel. Conversely, a directional tread pattern has a preferred direction of travel requiring specific wheel positioning.

[0016] “Outboard side” means the side of the tire farthest away from the vehicle when the tire is mounted on a wheel and the wheel is mounted on the vehicle.

[0017] “Peristaltic” means operating by means of wave-like contractions that propel contained matter, such as air, along tubular pathways.

[0018] “Radial” and “radially” means directions radially toward or away from the axis of rotation of the tire.

[0019] “Rib” means a circumferentially extending strip of rubber on the tread which is defined by at least one circumferential groove and either a second such groove or a lateral edge, the strip being laterally undivided by full-depth grooves.

[0020] “Sipe” means small slots molded into the tread elements of the tire that subdivide the tread surface and improve traction, sipes are generally narrow in width and close in the tires footprint as opposed to grooves that remain open in the tire’s footprint.

[0021] “Tread element” or “traction element” means a rib or a block element defined by having shape adjacent grooves.

[0022] “Tread Arc Width” means the arc length of the tread as measured between the lateral edges of the tread.

BRIEF DESCRIPTION OF THE DRAWINGS

[0023] The invention will be described by way of example and with reference to the accompanying drawings in which:

[0024] FIG. 1 is an isometric view of tire and rim assembly showing a pump and regulator assembly.

[0025] FIG. 2 is a front view of the pump and regulator assembly as shown from inside the tire of FIG. 1.

[0026] FIG. 3 is an exploded view of the regulator assembly.

[0027] FIG. 4 is a section view of FIG. 2 in the direction 4-4 showing the regulator in the open position during operation.

[0028] FIG. 5 is a section view of FIG. 2 in the direction 4-4 showing the regulator in the closed position during operation.

[0029] FIG. 6 is a front view of a second embodiment of a regulator assembly as shown from inside the tire of FIG. 1.

[0030] FIG. 7 is an exploded view of the second embodiment of the regulator assembly.

[0031] FIG. 8 is a section view of FIG. 6 in the direction 8-8 showing the regulator in the open position during operation.

[0032] FIG. 8a is the same as FIG. 8, except that the coil spring has been replaced with a leaf spring.

[0033] FIG. 9 is a section view of FIG. 6 in the direction 8-8 showing the regulator in the closed position during operation.

[0034] FIG. 10 is a view from inside the tire during operation.

[0035] FIG. 11 is an exploded view of a pump outlet valve.

[0036] FIG. 12a is a cross-sectional view of the pump outlet valve in the closed position.

[0037] FIG. 12b is a cross-sectional view of the pump outlet valve during the cracking open position.

[0038] FIG. 12c is a cross-sectional view of the pump outlet valve in the open position.

[0039] FIG. 13 is a cross-sectional view of the lower tire sidewall.

[0040] FIG. 14 is a front view of the regulator and pump assembly illustrating a pump length of about 170 degrees.

[0041] FIG. 15 is a front view of the regulator and pump assembly illustrating a pump length of about 350 degrees.

DETAILED DESCRIPTION OF THE INVENTION

[0042] Referring to FIGS. 1 and 2, a tire assembly 10 includes a tire 12, a pump assembly 14, and a tire rim 16. The tire and rim enclose a tire cavity 40. As shown in FIGS. 1-2, the pump assembly 14 is preferably mounted into the sidewall area 15 of the tire, preferably near the bead region.

Pump Assembly 14

[0043] The pump assembly 14 includes an air passageway 43 which may be molded into the sidewall of the tire during vulcanization or formed post cure. When the air passageway is molded into the tire sidewall as shown in FIG. 2, the air passageway has an arc length L as measured by an angle Ψ that is measured from the center of rotation of the tire. In a first embodiment, the angle Ψ may range, and is preferably in the range of about 15-50 degrees or optionally, an angular length sufficient to extend the length of the tire footprint Z, as shown in FIG. 10. The air passageway has an arc length L that may extend in a circumferential direction, or any direction. The arc length L may range, and is preferably about the length of the tire footprint Z, as shown in FIG. 10. The length is typically about 20-40 degrees when the shorter length is used. Alternatively, the pump tube length may be any desired length, typically 20 degrees or more. The pump air passageway 43 is comprised of a tube body formed of a resilient, flexible material such as plastic, elastomer or rubber compounds, and is capable of withstanding repeated deformation cycles when the tube is deformed into a flattened condition subject to external force and, upon removal of such force, returns to an original condition generally circular in cross-section. The tube is of a diameter sufficient to operatively pass a volume of air sufficient for the purposes described herein and allowing a positioning of the tube in an operable location within the tire assembly as will be described. Preferably, the tube has a circular cross-sectional shape, although other shapes such as elliptical may be utilized. The tube may be a discrete tube that is inserted into the tire during tire manufacturing, or the tube

may be molded into shape by the presence of a removable strip that forms the passageway when removed.

[0044] As shown in FIG. 2, the pump passageway 43 has an inlet end 42 connected to an inlet fitting 100, and an outlet end 44 that is connected to an outlet valve 200. The inlet fitting 100 is in fluid communication with an inlet control valve 300. The inlet control valve 300 is in fluid communication with an inlet filter assembly 450.

Inlet Control Valve

[0045] A first embodiment of an inlet control valve 300 is shown in FIGS. 2-5. The inlet control valve 300 functions to regulate the flow of air to the pump 14. The inlet control valve 300 has a central housing 310 that houses an interior chamber 320. The interior chamber 320 has a central opening 312. Opposite the central opening 312 is an outlet port 330. The outlet port is raised from the bottom surface 313 and extends into the interior of the chamber 320. The outlet port is positioned to engage a pressure membrane 550.

[0046] The pressure membrane has an upper surface 551 that is substantially planar. The pressure membrane has a lower surface 553 wherein a plug 555 extends from the lower surface. The pressure membrane further has an annular sidewall 556 which extends downwardly from the upper surface, forming a lip 557. The lip 557 is preferably annular, and snaps in an annular cutout 559 formed on the outer housing 310. The pressure membrane is a disk shaped member made of a flexible material such as, but not limited to, rubber, elastomer, plastic or silicone. The outer surface 551 of the pressure membrane is in fluid communication with the pressure of the tire chamber 40. The lower surface 553 of the pressure membrane is in fluid communication with the interior chamber 320. The plug 555 is positioned to close the outlet port 330. A spring 580 is positioned in the interior chamber 320 to bias the pressure membrane 550 in the open position. The spring has a first end 582 that is received about the plug 555. The spring has a second end 584 that is wrapped around the outer surface of the outlet port 330. A first washer 586 may be received between the spring first end 582 and the pressure membrane 550. A second washer 588 may be received between the spring second end 584 and the bottom of the chamber 313. Thus the balance of pressure forces on each side of the pressure membrane actuates the pressure membrane plug 555 to open and close the outlet port 330. A membrane support member 590 is received over the pressure membrane 550. The membrane support member 590 has a plurality of holes 592 in the outer surface 591 of the lid, to allow the pressure membrane to be in fluid communication with the tire cavity 40. The membrane support member 590 is formed of a rigid material, and the support member allows a preloading of the spring via the pressure membrane.

[0047] Extending from the central housing 310 is a first and second flexible duct 400, 500, positioned on either side of the central housing 310. Each flexible duct 400, 500 may be integrally formed with the central housing as shown, or be a discrete part connected to the central housing 310. Each flexible duct 400, 500 has an internal passageway 404, 504 for communicating fluid.

[0048] The internal passageway 404 of the first flexible duct 400 has a first opening 402 that is located inside the interior chamber 320. The internal passageway 404 of the first flexible duct 400 has a second end 406 that is in fluid communication with an inlet filter assembly 450. The inlet device

450 supplies outside filtered air to the regulator via the first flexible duct **400**, and is described in more detail below.

[0049] The internal passageway **504** of the second flexible duct **500** is shown integrally formed with the outlet port **330** of the interior chamber **320**. The internal passageway **504** has a second end **506** in fluid communication with an inlet fitting **100**. The inlet fitting **100** may be a hollow screw such as a banjo screw. The inlet fitting **100** has an internal passageway **102** with inlet holes **104** that communicate flow to the inlet **42** of the pump passageway **43**. The inlet fitting **100** may comprise a screw with an internal passageway, and has an outer threaded surface **106** that is received in a sleeve **110**. The sleeve **110** has a bore that extends completely therethrough. The sleeve is mounted in the tire.

[0050] A second embodiment of the inlet control valve **1100** is shown in FIGS. 6-9. The inlet control valve **1100** is the same as **300** except for the following differences. The membrane **1102** does not have a plug **555** on the lower surface. The membrane has a non-planar upper surface with a recessed interior portion **1104**. The recessed interior portion extends into the interior of the interior chamber and is positioned to open and close the outlet passageway **330**. A coil spring **580** is positioned to bias the pressure membrane in the open position. The coil spring **580** may be replaced with a leaf spring **583** as shown in FIG. 8A.

Inlet Filter Assembly

[0051] The inlet filter assembly **450** is shown in FIG. 4. The inlet filter assembly **450** includes an insert sleeve **452** that is hollow and has an internal threaded bore **454**. The insert sleeve **452** is inserted into the tire, typically in the sidewall **15**. The insert sleeve **452** may be inserted into the tire post cure or may be molded into the tire as shown in FIG. 2. An air passage screw **460** has an outer threaded body **463** that is screwed into the internal threaded bore **454** of the insert sleeve. The air passage screw **460** has an internal passageway **462** having an opening **464**. A filter **470** is inserted through opening **464** and is received in the internal passageway **462**. A filter cap **480** has a threaded end **482** that is received in the opening **464** of the air passage screw **460**. The filter cap is positioned on the outside surface of the tire, typically on the tire sidewall as shown in FIG. 1. The filter cap has a plurality of holes **484** for allowing the flow of air into the inlet filter **470**. Outside air enters hole **484** and then through the filter cap into and through filter **470**. The filter air exits the filter **470** into the internal passageway **462** of the air passage screw **460**. The air exits the internal passageway **462** through exit hole **490** and then into the inlet end **406** of the first flexible duct **400**. The inlet end of the flexible duct **400** has a circular flange **495** surrounding a hole **410** through which the air passage screw is inserted. The exit hole **490** is located in a circumferential groove **491** to facilitate fluid communication with inlet hole **406** of the first flexible duct **400**. The circular flange **495** functions like a sealing gasket if it is made of a flexible soft material like rubber.

Pump Outlet Check Valve

[0052] As described above, a first end **42** of the pump is connected to a regulator and a check valve. The second end **44** of the pump is connected to a pump outlet valve **200**. The pump outlet valve is shown in FIGS. 11, 12A-C. The pump outlet valve **200** includes an insert sleeve **202** that is inserted into the tire on an interior surface, typically the inner sidewall

as shown in FIG. 2. The insert sleeve **202** has an internal threaded bore **204**. The insert sleeve **202** may be molded into the tire **12** or inserted post cure. The insert is installed in the tire area so that the internal bore **204** is in fluid communication with the pump outlet end **44**. A valve body **210** has an outer threaded surface **212** that is received within insert **202**. The valve body **210** has a central passage **215** that has a first opening **218** that is in fluid communication with the insert sleeve bore **204** and the pump passageway **43** outlet end **44** when inserted into the tire. The central passage **215** has an outlet end **217** that is in fluid communication with the tire cavity. The valve body has a shaped head **222** such as a hexagonal shaped head bore **223** for receiving a mating tool such as an allen wrench useful for tightening the valve body **210** inside the sleeve **202**. The central passage **215** further includes a retainer slot **230** for receiving flexible stopper **240**. The flexible stopper **240** is preferably made of a resilient material such as rubber, silicone, or an elastomer. The flexible stopper **240** has a disk shaped lower end **242**, and two opposed legs **244** which extend from the lower end **242**. Each leg **244** has a shoe **250** which has a curved enlarged shape and is made of a resilient material. As shown, the shoe is a semi-circle, although other shapes would work for the invention. Although the flexible stopper **240** is shown with two legs **244**, the stopper could have a single leg **244** with a shoe thereon, and the shoe could be annular with holes that allow passage of air therethrough.

[0053] The flexible stopper is mounted inside the central passage so that each shoe **250** of the flexible stopper is received in the annular retainer slot **230**, and the disk lower end **242** is positioned to open and close the pump end **44**.

[0054] FIGS. 12A-C illustrate the pump outlet valve **200** installed and operational. FIG. 12C illustrates flow from the pump outlet **44** to the pump outlet valve **200**. The disk lower end **242** of the flexible stopper **240** does not seal the pump outlet **44** when the flow direction is towards the pump outlet valve **200**. The flow travels through the central passage **215**, around and through the legs **244** and exits the passage outlet **217** to the tire cavity. FIG. 12A illustrates the disk lower end **142** of the flexible stopper **140** sealing the pump end **44** so that flow is blocked from flowing to the tire cavity **40**. FIG. 12B illustrates the disk lower end **142** of the flexible stopper **140** being lifted by the valve cracking pressure when the pump starts pumping.

[0055] An additional check valve like the check valve **200** may be optionally used between the pump inlet passageway **42** and the outlet of the regulator.

System Operation

[0056] As will be appreciated from FIG. 2, the inlet control valve **300** is in fluid communication with the inlet end of the pump passageway **43**. As shown in FIG. 10, as the tire rotates, a footprint is formed against the ground surface. A compressive force **F** is directed into the tire from the footprint and acts to flatten the pump passageway **43**. Flattening of the pump passageway **43** forces the compressed air towards the pump outlet device **200**. Due to the increase in pressure at the pump outlet **44**, the pressure unseats the disk **242** from the opening of the pump outlet **44**, which allows the pumped air to exit the pump outlet device through passage **215** into the tire cavity **40**, as shown in FIG. 12C.

[0057] The inlet control valve **300** controls the flow of outside air into the pump. If the tire pressure is low, the membrane **550** in the inlet control valve **300** is responsive to

the tire pressure in the tire cavity **40**. If the tire cavity pressure falls below a preset threshold value, the plug of the membrane will unseat from the central outlet port **330**. Outside air will enter the filter assembly **450**, exit through the filter and enter the first flexible duct **400**, as shown in FIGS. **4** and **8**. The flow then exits the first flexible duct and enters the chamber and then into the second flexible duct, through the inlet fitting **100** and then into the pump inlet. The flow is then compressed through the pump and then exits the pump outlet valve into the tire cavity. The pump will pump air with each tire rotation. The pump passageway **43** fills with air when the pump system is not in the footprint.

[0058] If the tire pressure is sufficient, the inlet control valve will block flow from exiting the inlet control valve, as shown in FIGS. **5** and **9**. The pressure membrane is responsive to the cavity tire pressure and engages the central port **330** forming a seal which prevents air flow from passing through the inlet control valve. The pressure membrane material properties are adjusted to have the desired tire pressure settings.

[0059] The location of the pump assembly in the tire will be understood from FIGS. **1** and **13**. In one embodiment, the pump assembly **14** is positioned in the tire sidewall, radially outward of the rim flange surface in the chafer **600**. So positioned, the air passageway **43** is radially inward from the tire footprint and is thus positioned to be flattened by forces directed from the tire footprint as described above. Although the positioning of the air passageway **43** is specifically shown in a chafer **600** of the tire near the bead region, it is not limited to same, and may be located at any region of the tire that undergoes cyclical compression. The cross-sectional shape of the air passageway **43** may be elliptical or round.

[0060] As described above, the length L of the pump passageway may be about the size of the tire's footprint length Z. However, the invention is not limited to same, and may be shorter or longer as desired. See FIG. **14** which illustrates an approximate 170 degree length, FIG. **15** which illustrates an approximate 340 degree length. As the length of the pump increases, the pump passageway will need to substantially open and close like a peristaltic pump.

[0061] The pump assembly **14** may also be used with a secondary tire pressure monitoring system (TPMS) (not shown) of conventional configuration that serves as a system fault detector. The TPMS may be used to detect any fault in the self-inflation system of the tire assembly and alert the user of such a condition.

[0062] Variations in the present invention are possible in light of the description of it provided herein. While certain representative embodiments and details have been shown for the purpose of illustrating the subject invention, it will be apparent to those skilled in this art that various changes and modifications can be made therein without departing from the scope of the subject invention. It is, therefore, to be understood that changes can be made in the particular embodiments described which will be within the full intended scope of the invention as defined by the following appended claims.

What is claimed is:

1. A self-inflating tire assembly comprising:

a tire mounted to a rim, the tire having a tire cavity, first and second sidewalls extending respectively from first and second tire bead regions to a tire tread region;

an air passageway having an inlet end and an outlet end, the air passageway being composed of a flexible material

operative to open and close when the tire rotates, wherein the outlet end is in fluid communication with the tire cavity;

the inlet control valve having a regulator body having an interior chamber; a pressure membrane being mounted on the inlet control valve to enclose the interior chamber, wherein the pressure membrane has a lower surface that is positioned to open and close the outlet port mounted in the interior chamber, wherein the pressure membrane is in fluid communication with the tire cavity pressure; wherein the body of the inlet control valve has a first and second flexible duct, wherein said first and second flexible ducts each have an internal passageway; wherein the first flexible duct has a first end connected to an inlet filter assembly and a second end is connected to the interior chamber of the inlet control valve, wherein the second flexible duct has a first end connected to the outlet port of the inlet control valve, and a second end in fluid communication with the inlet end of the air passageway.

2. The self-inflating tire assembly of claim **1** wherein the air passageway is integrally formed in the sidewall of the tire.

3. The self-inflating tire assembly of claim **1** wherein a spring biases the pressure membrane in the open position.

4. The self-inflating tire assembly of claim **3** wherein the spring is a leaf spring.

5. The self-inflating tire assembly of claim **1** wherein the regulator body is not affixed or mounted in the tire.

6. The self-inflating tire assembly of claim **1** wherein the inlet device has a filter.

7. The self-inflating tire assembly of claim **1**, wherein the length of the air passageway is greater than 10 degrees.

8. The self-inflating tire assembly of claim **1**, wherein the length of the air passageway is about the same as the length of the tire footprint.

9. The self-inflating tire assembly of claim **1**, wherein the length of the air passageway is in the range of about 10 to about 30 degrees.

10. The self-inflating tire assembly of claim **1**, wherein the air passageway is substantially of elliptical in cross-section.

11. The self-inflating tire assembly of claim **1**, wherein the air passageway is positioned in the chafer.

12. The self-inflating tire assembly of claim **1**, wherein the air passageway is positioned between a tire bead region and the rim tire mounting surface radially inward of the tire tread region.

13. The self-inflating tire assembly of claim **1**, wherein a first check valve is located between the outlet of the air passageway and the tire cavity.

14. The self-inflating tire assembly of claim **1**, wherein a second check valve is located between the inlet of the air passageway and the outlet of the regulator.

15. The self-inflating tire assembly of claim **14** wherein the second check valve is mounted to the tire.

16. The self-inflating tire assembly of claim **1** wherein the filter assembly has an insert sleeve affixed to the tire sidewall, wherein the insert sleeve has an internally threaded bore that extends completely therethrough, wherein the internal bore has a first end in the tire cavity and a second end open to the ambient air outside the tire, an air passage screw having an internal passageway is received in the first end of the insert sleeve, a filter is received within the internal passageway of the air passage screw.

17. The self-inflating tire assembly of claim **15** wherein the first check valve has an insert sleeve affixed to the tire sidewall, wherein the insert sleeve has an internally threaded bore that extends completely therethrough, wherein the internal bore has a first end open to the tire cavity, and a second end connected to the air passageway outlet end, wherein a flexible stopper is received in the internal bore.

18. The self-inflating tire assembly of claim **18** wherein the flexible stopper has a disk shaped lower end that is positioned to open and close the air passageway outlet end.

* * * * *