



US 20150059950A1

(19) **United States**

(12) **Patent Application Publication**
Hinque

(10) **Pub. No.: US 2015/0059950 A1**

(43) **Pub. Date: Mar. 5, 2015**

(54) **COMPACT VALVE SYSTEM FOR SELF-INFLATING TIRE**

(52) **U.S. Cl.**

CPC **B60C 23/12** (2013.01)

USPC **152/450**

(71) Applicant: **The Goodyear Tire & Rubber Company, Akron, OH (US)**

(57) **ABSTRACT**

(72) Inventor: **Daniel Paul Luc Marie Hinque, Habay-la-Neuve (BE)**

A tire having a tire cavity is disclosed, wherein the tire has a bi-directional pump assembly including a pump passageway having an inlet end and an outlet end, and being operative to allow a portion of the pump passageway near a tire footprint to substantially close and open the pump passageway. The tire includes a valve assembly having a valve housing, wherein a diaphragm is mounted in the valve housing forming an interior chamber, and wherein the diaphragm is responsive to the pressure of the tire cavity. The interior chamber has an inlet in fluid communication with outside air, and an outlet in fluid communication with inlet and outlet of the pump passageway. The valve assembly further includes an inlet control valve having a valve bottom positioned over the outlet and operative to open and close the outlet. The inlet control valve has a first end connected to the diaphragm, and a resilient member biases the inlet control valve into the open position.

(73) Assignee: **The Goodyear Tire & Rubber Company, Akron, OH (US)**

(21) Appl. No.: **14/013,852**

(22) Filed: **Aug. 29, 2013**

Publication Classification

(51) **Int. Cl.**
B60C 23/12 (2006.01)

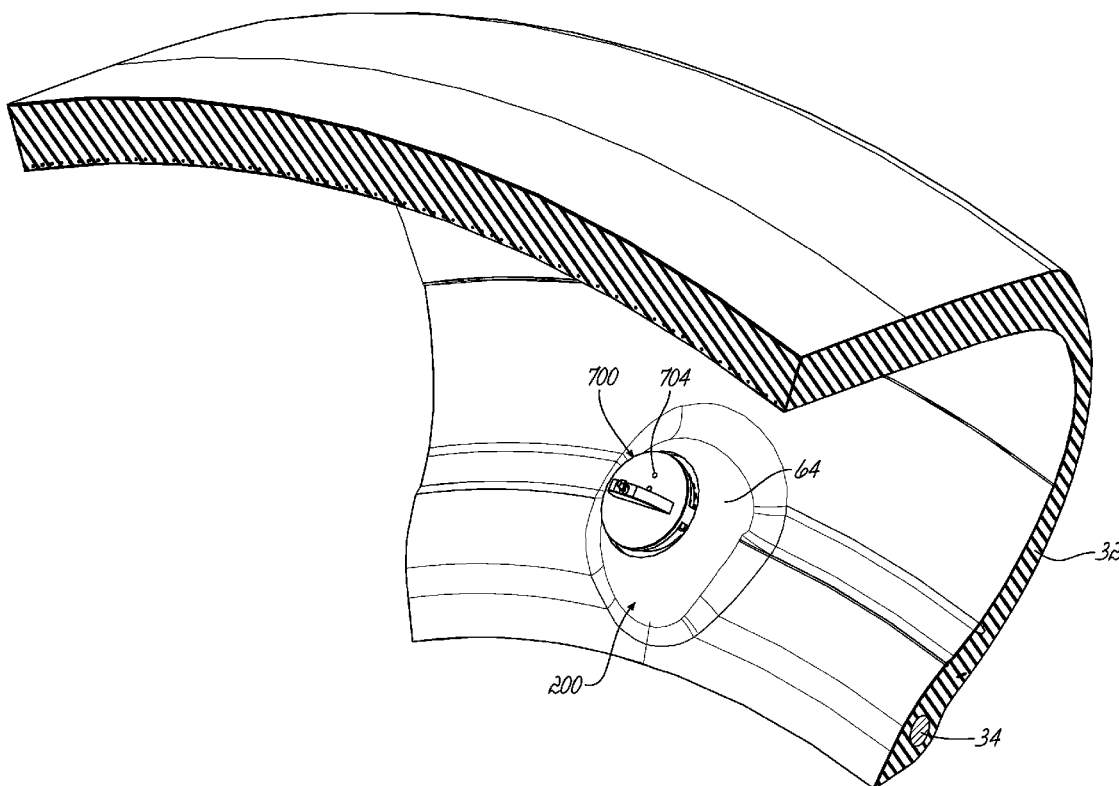

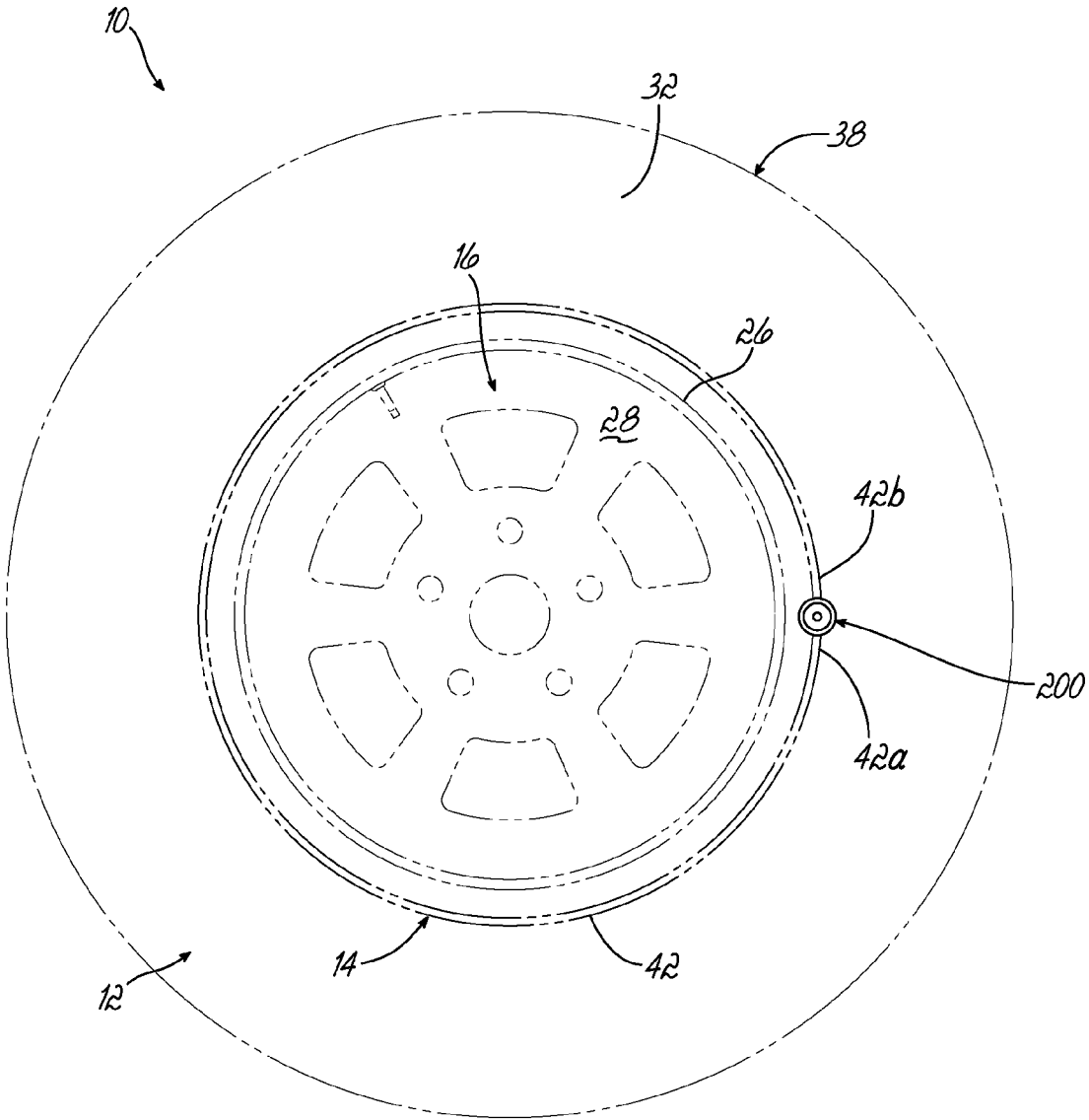

FIG. 1

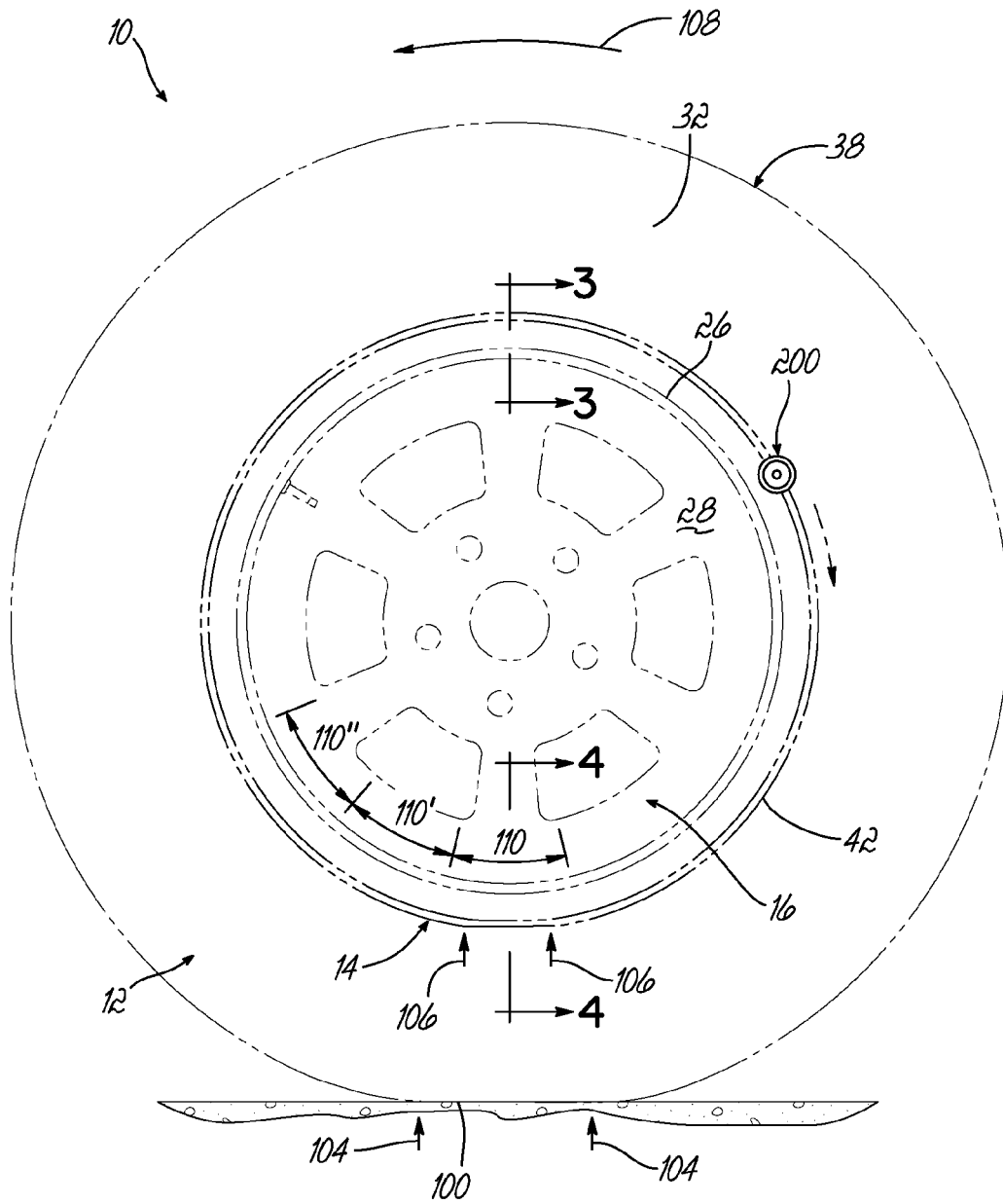

FIG. 2

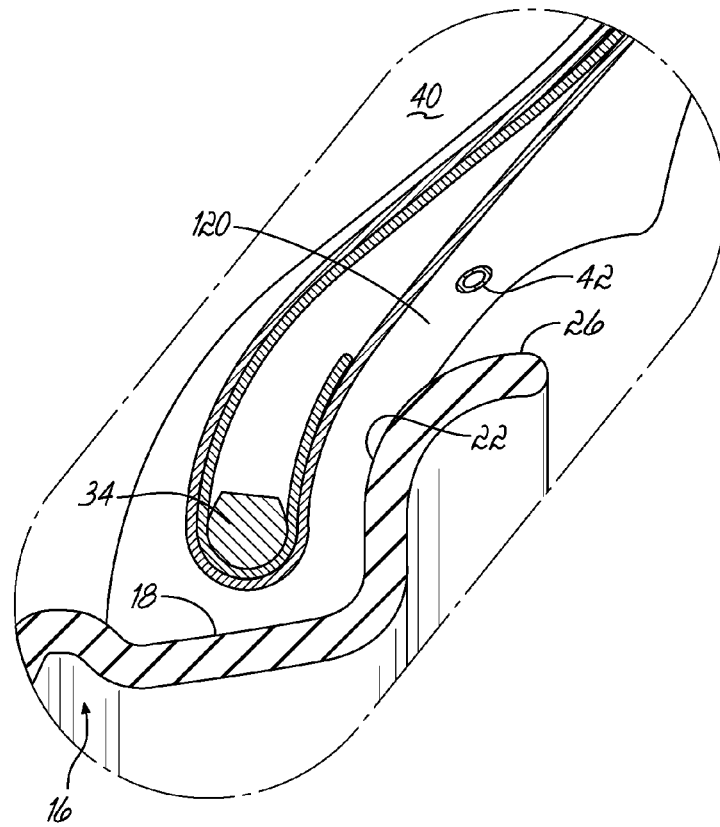

FIG. 3

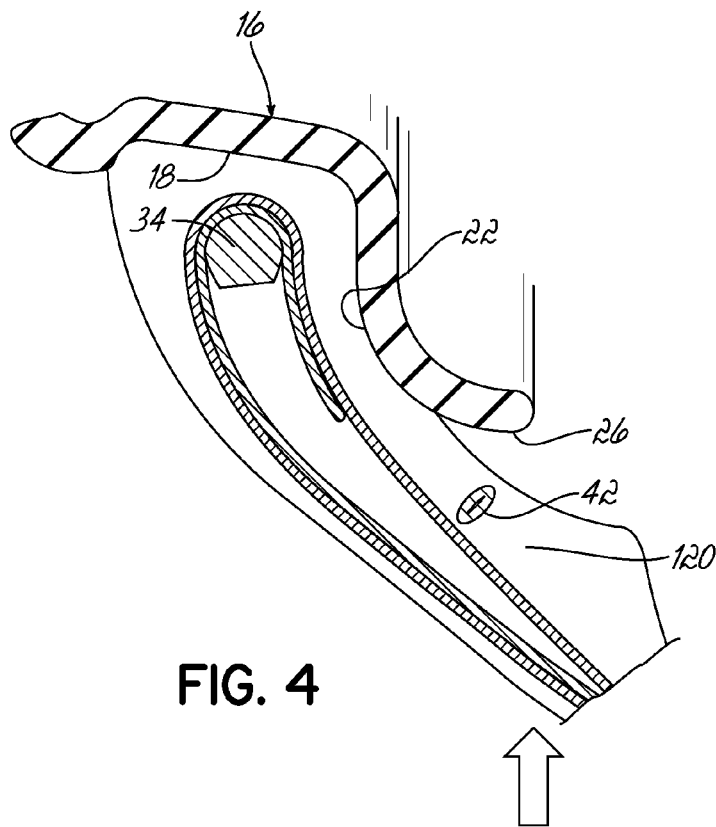

FIG. 4

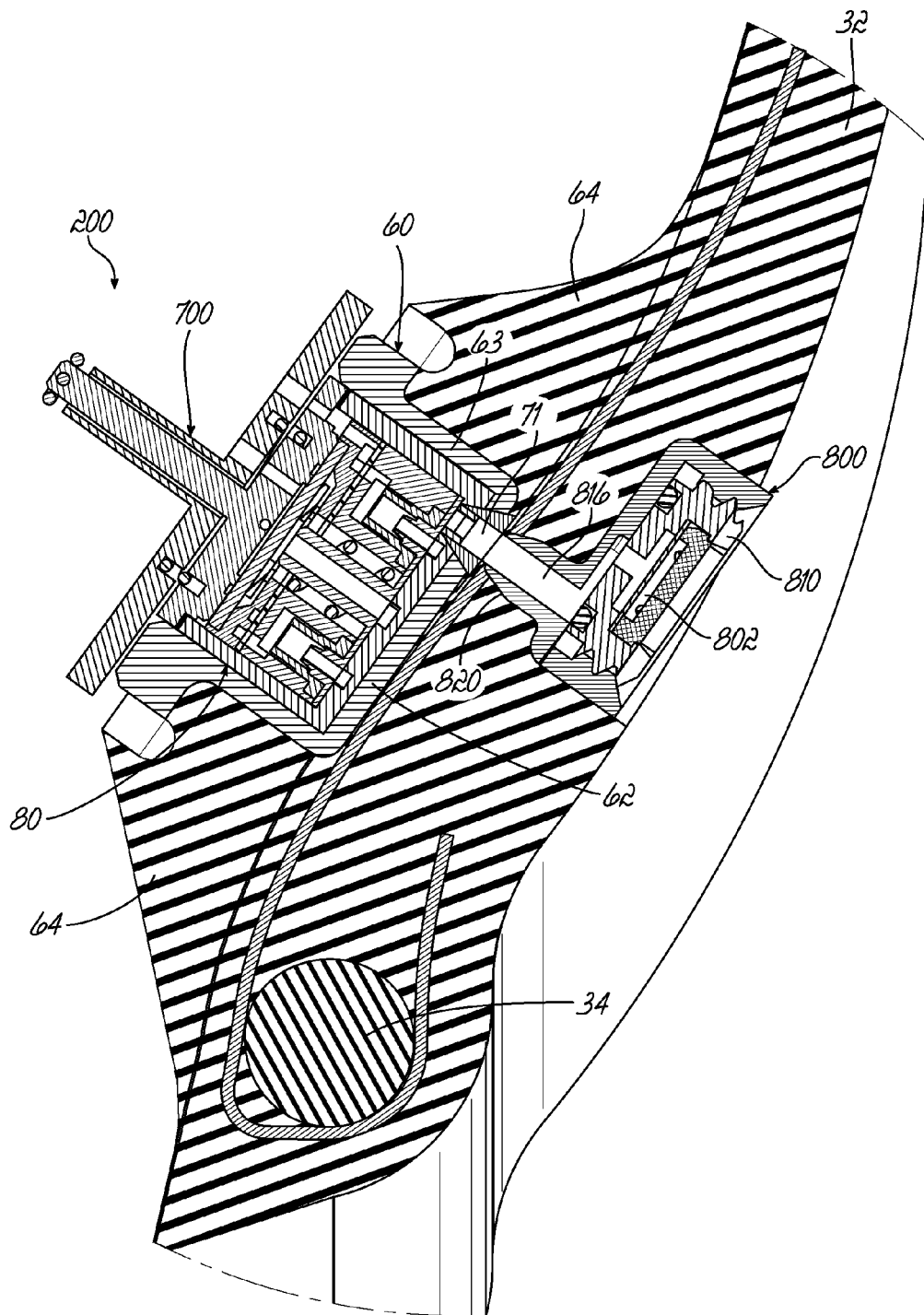

FIG. 5A

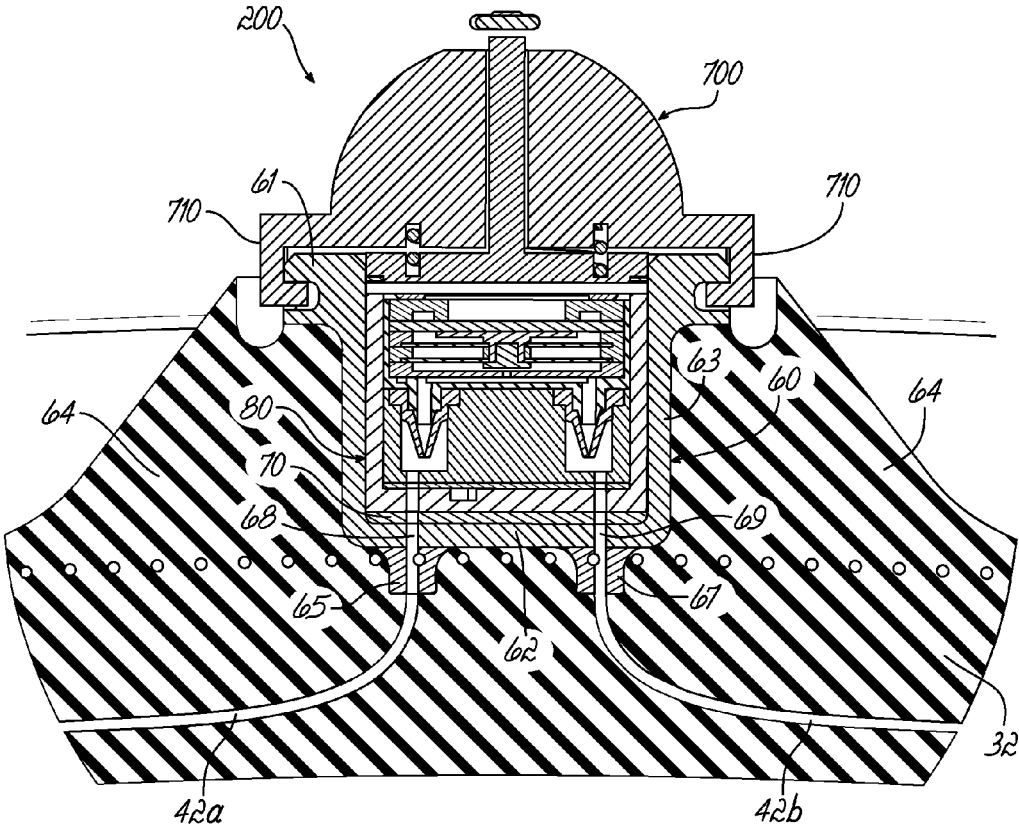

FIG. 5B

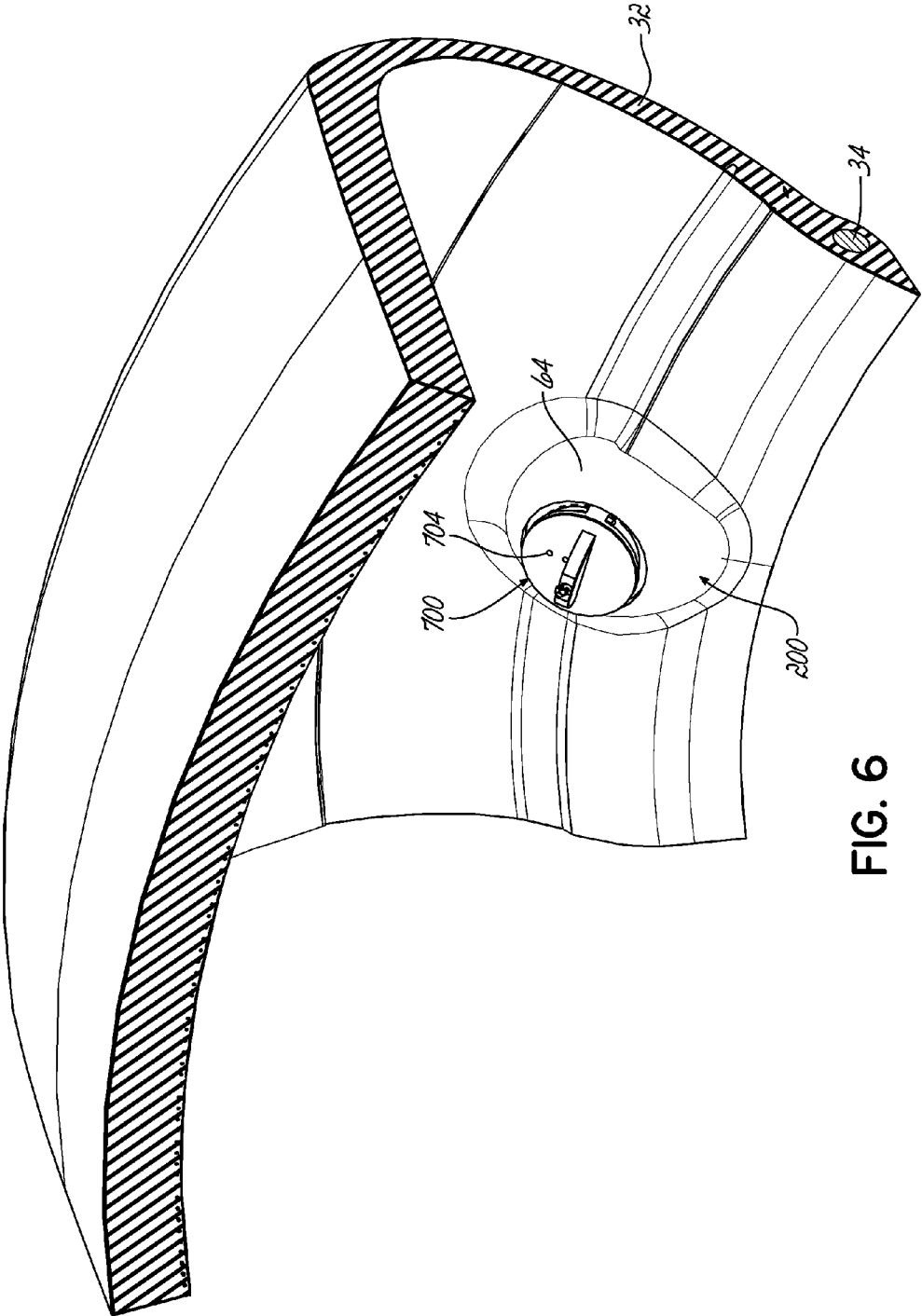

FIG. 6

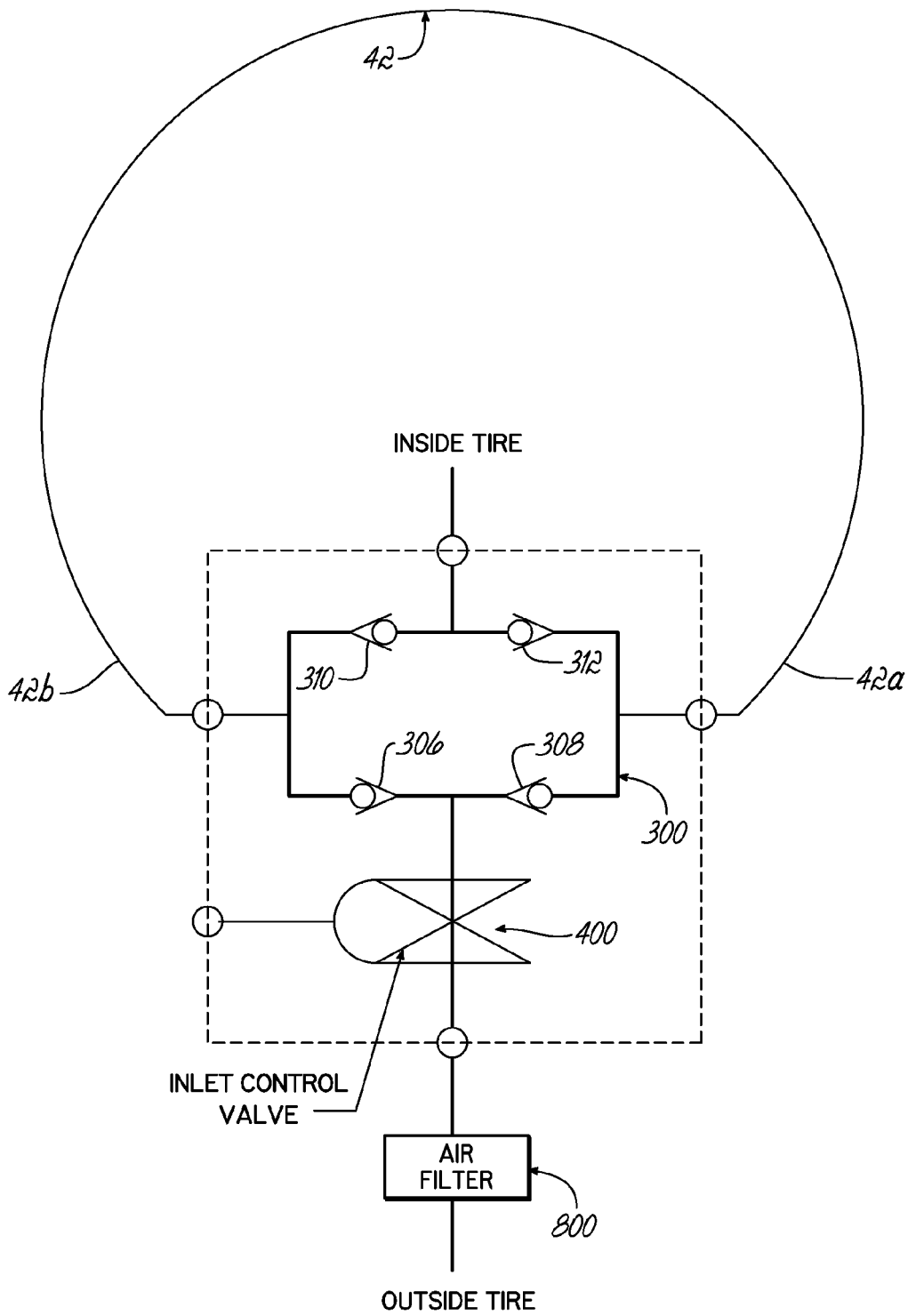

FIG. 7

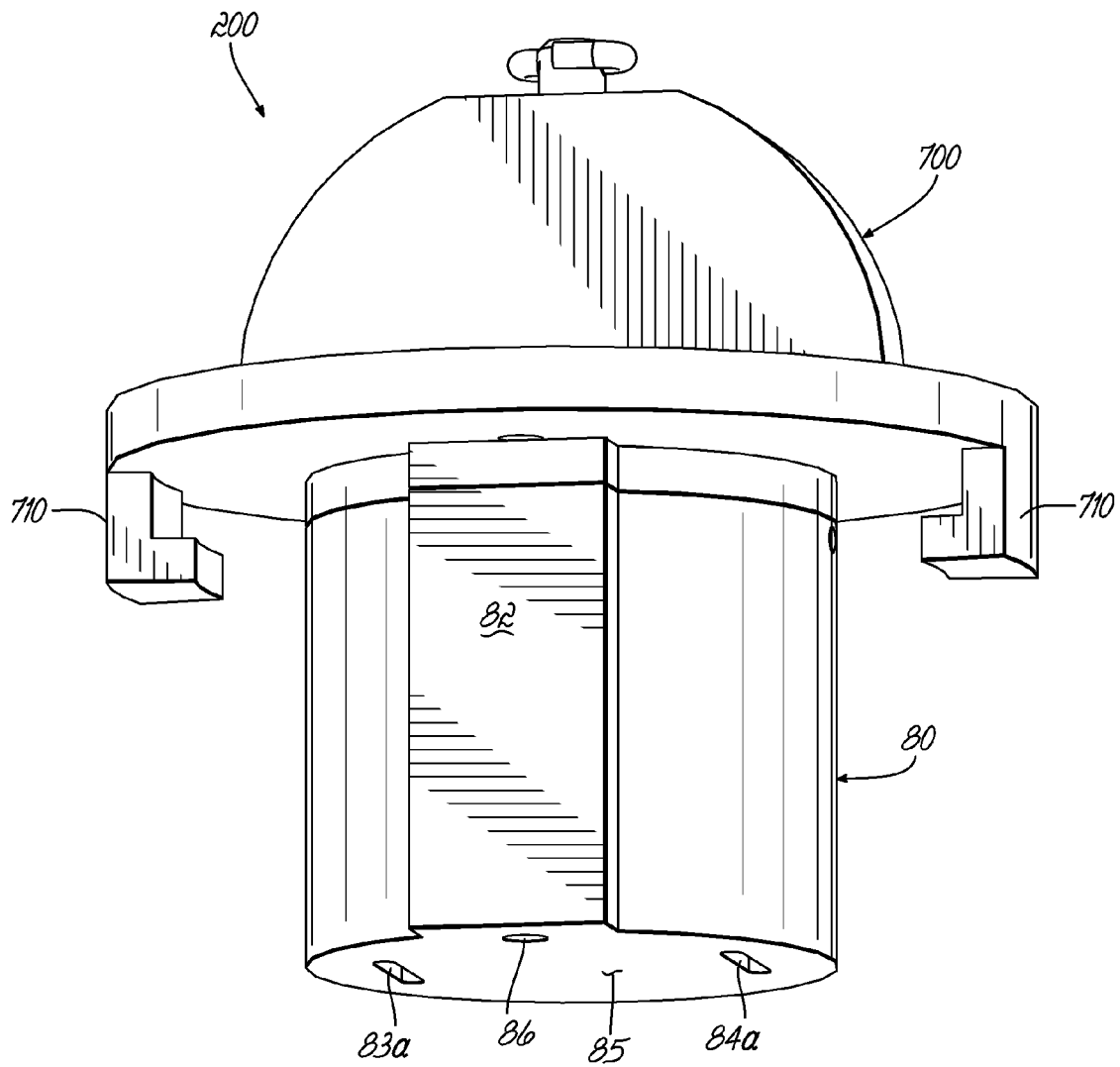

FIG. 8

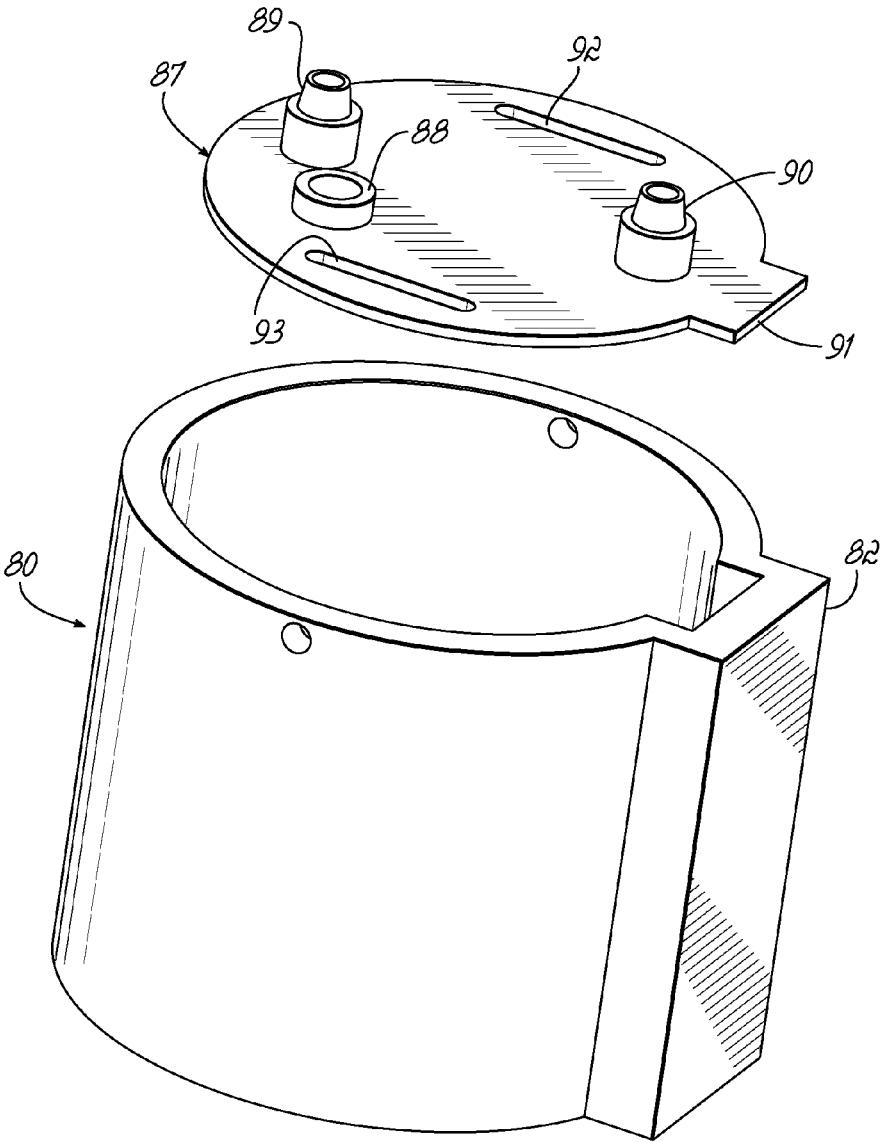
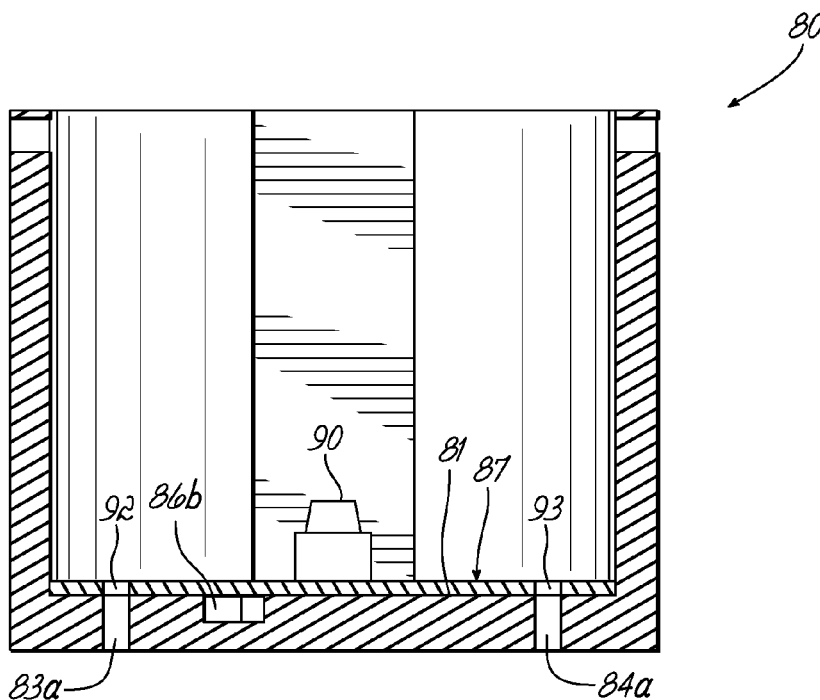
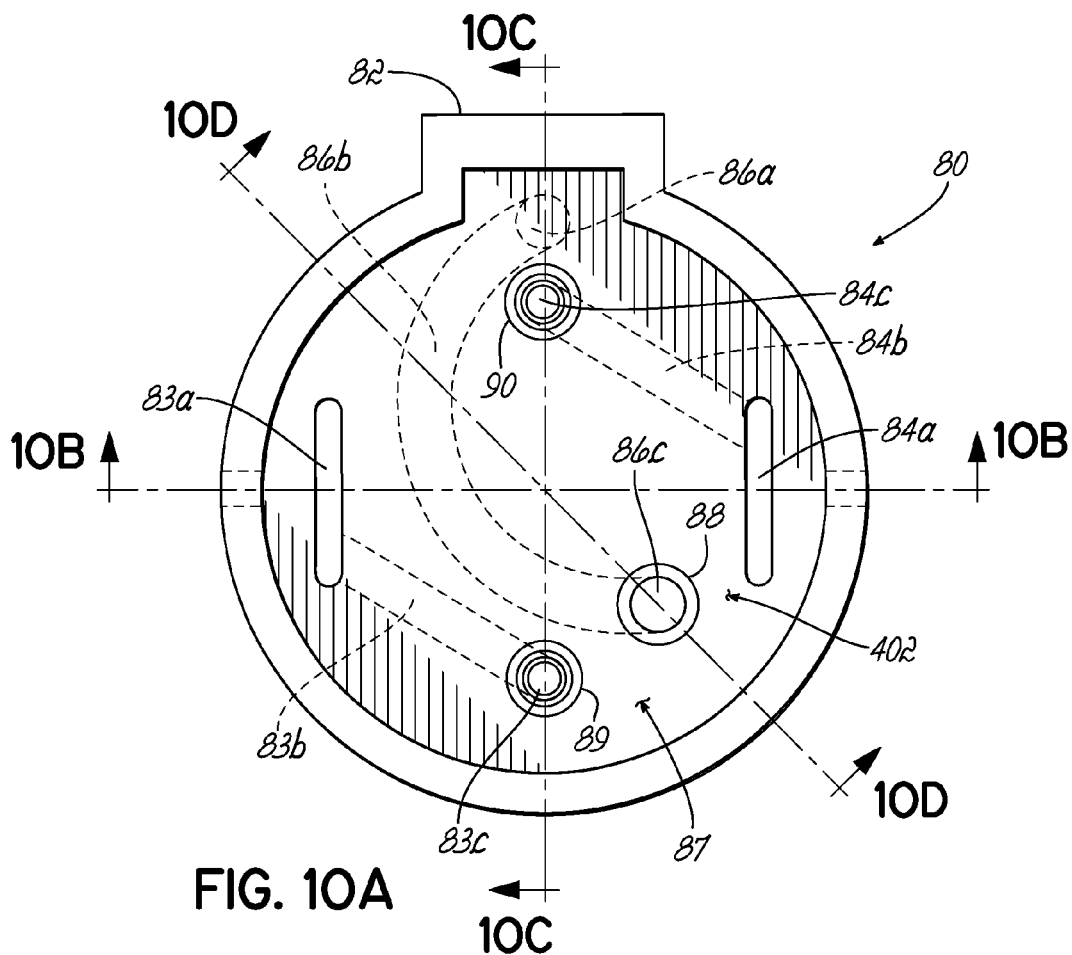

FIG. 9



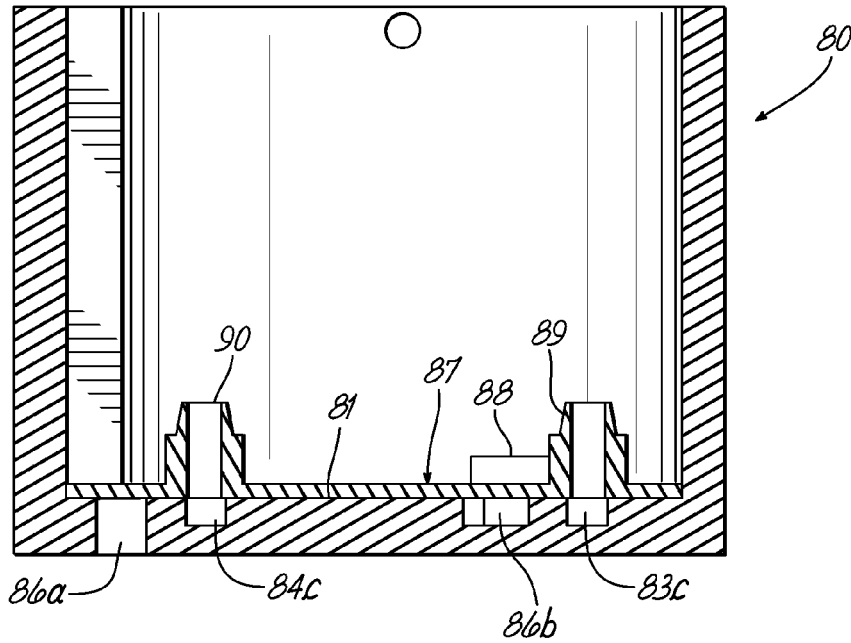

FIG. 10C

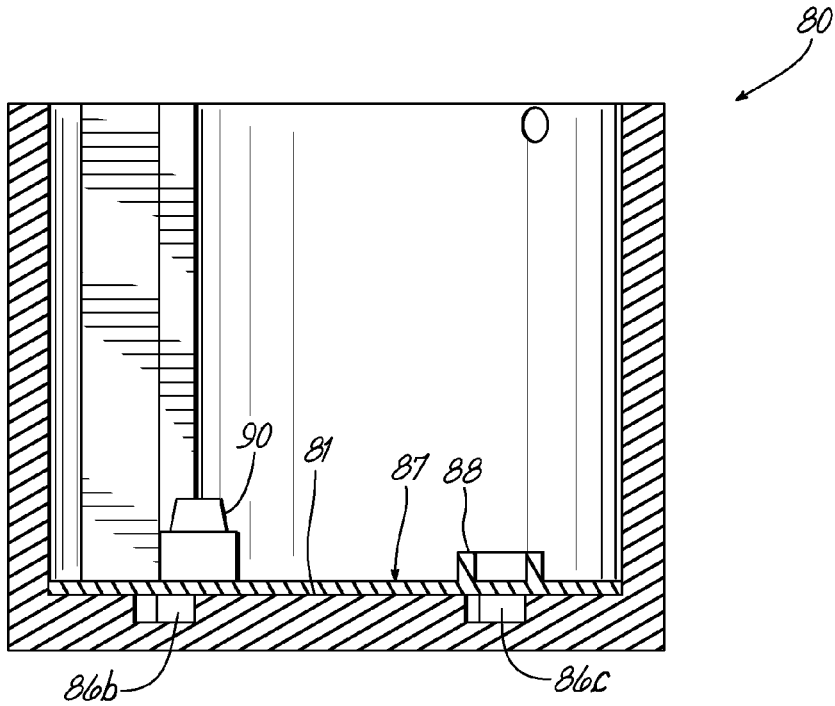

FIG. 10D

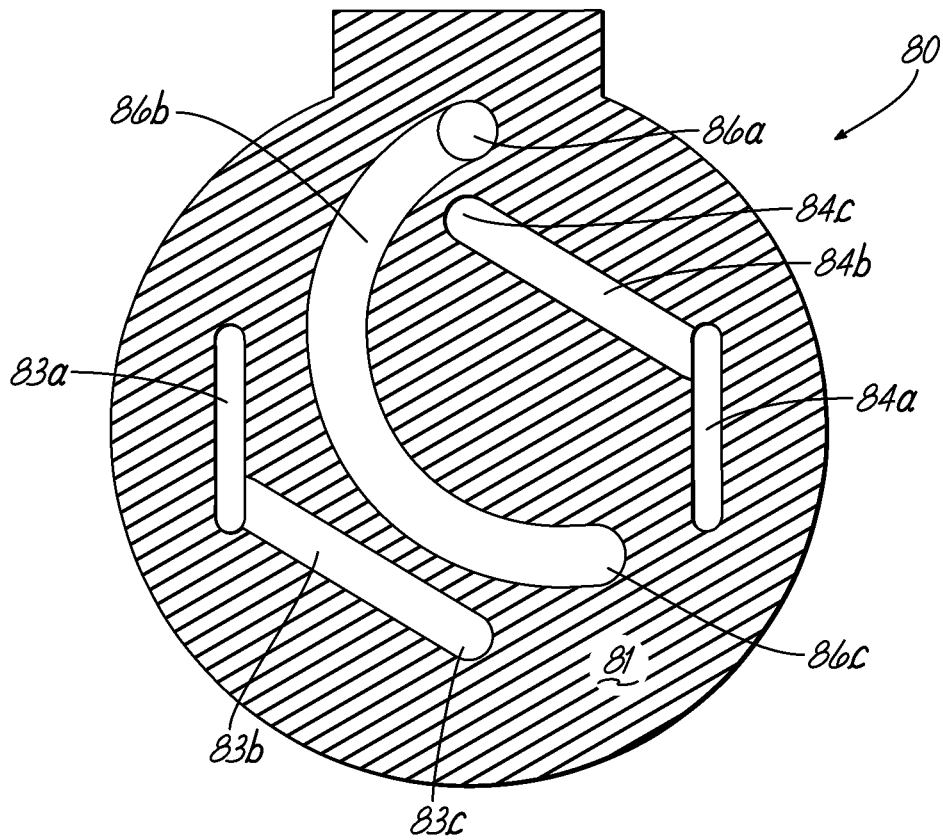

FIG. 10E

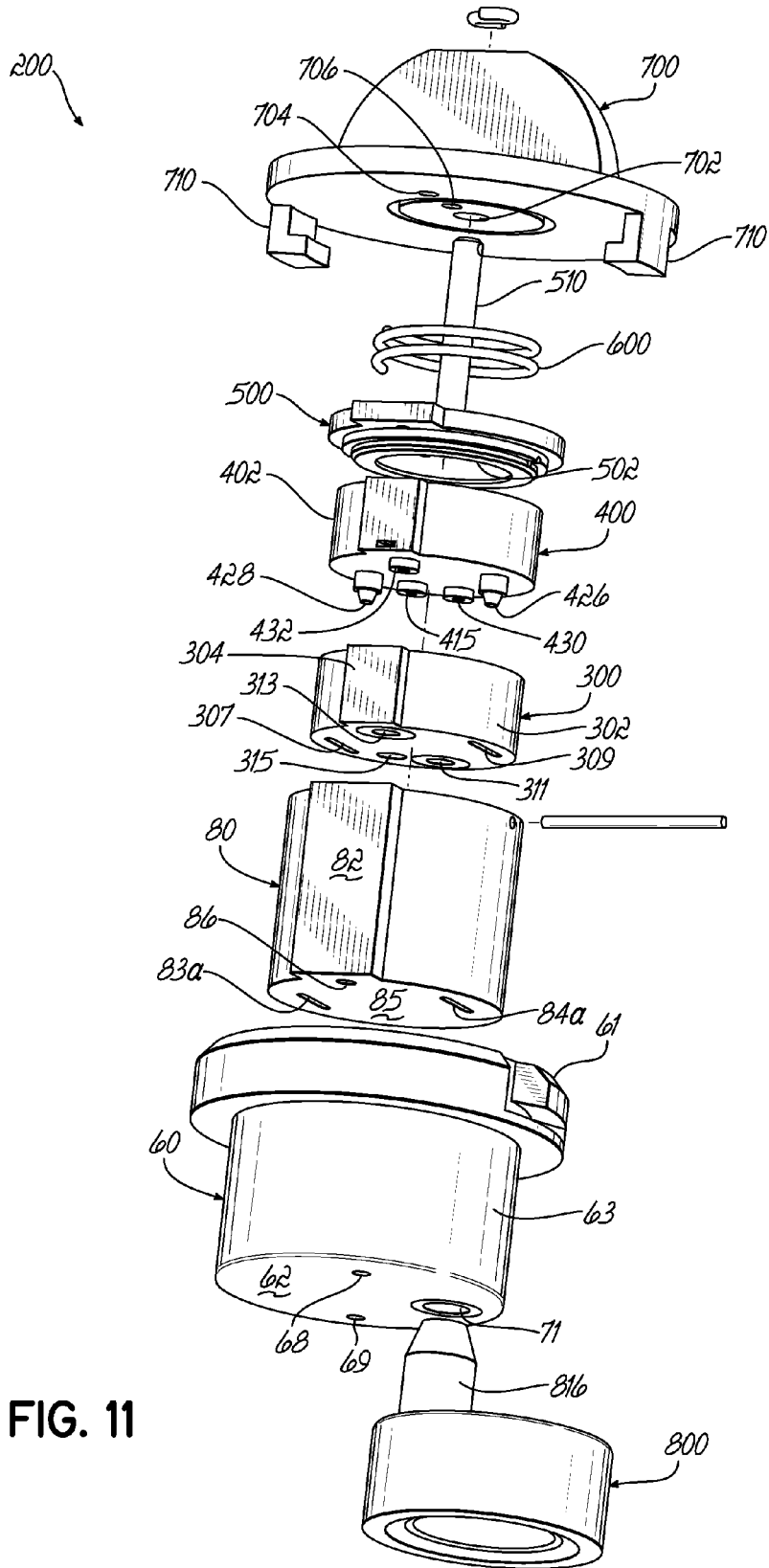

FIG. 11

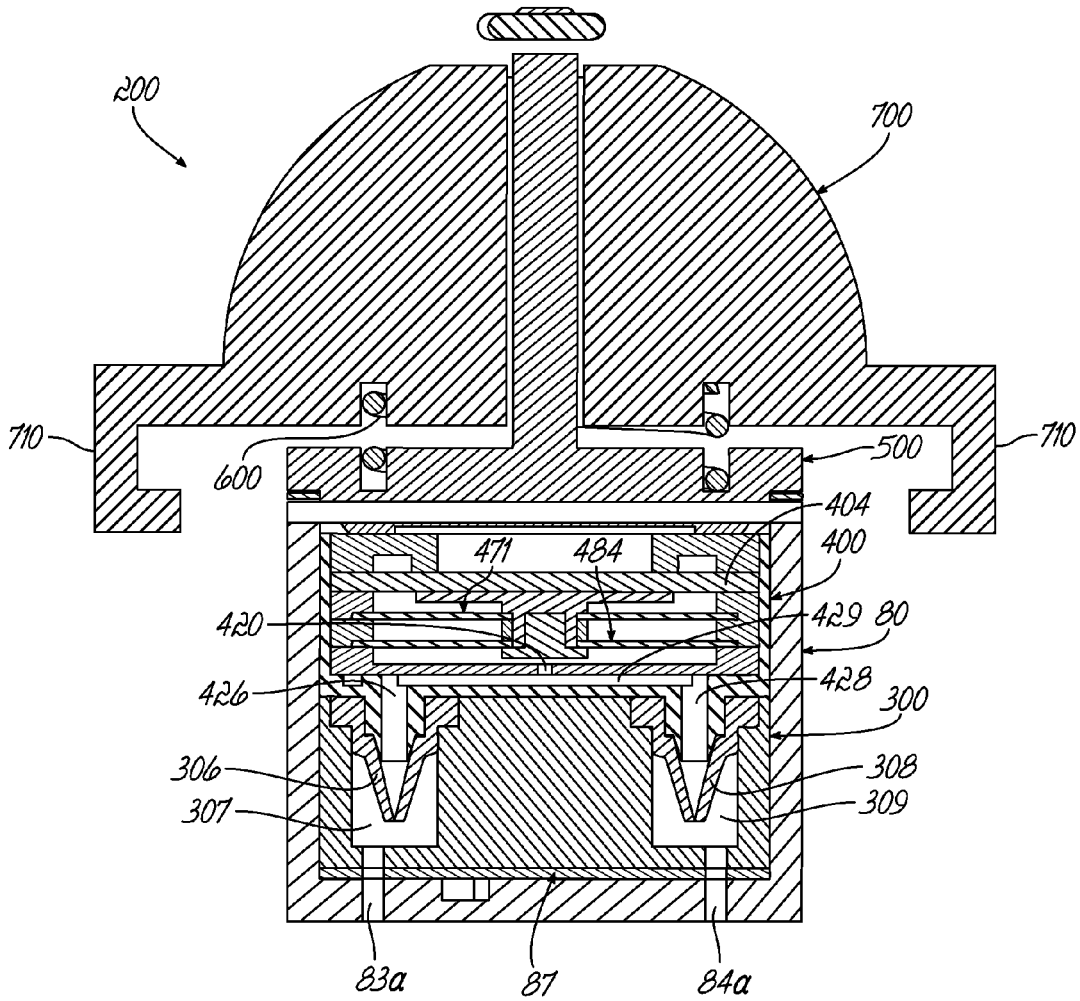

FIG. 12

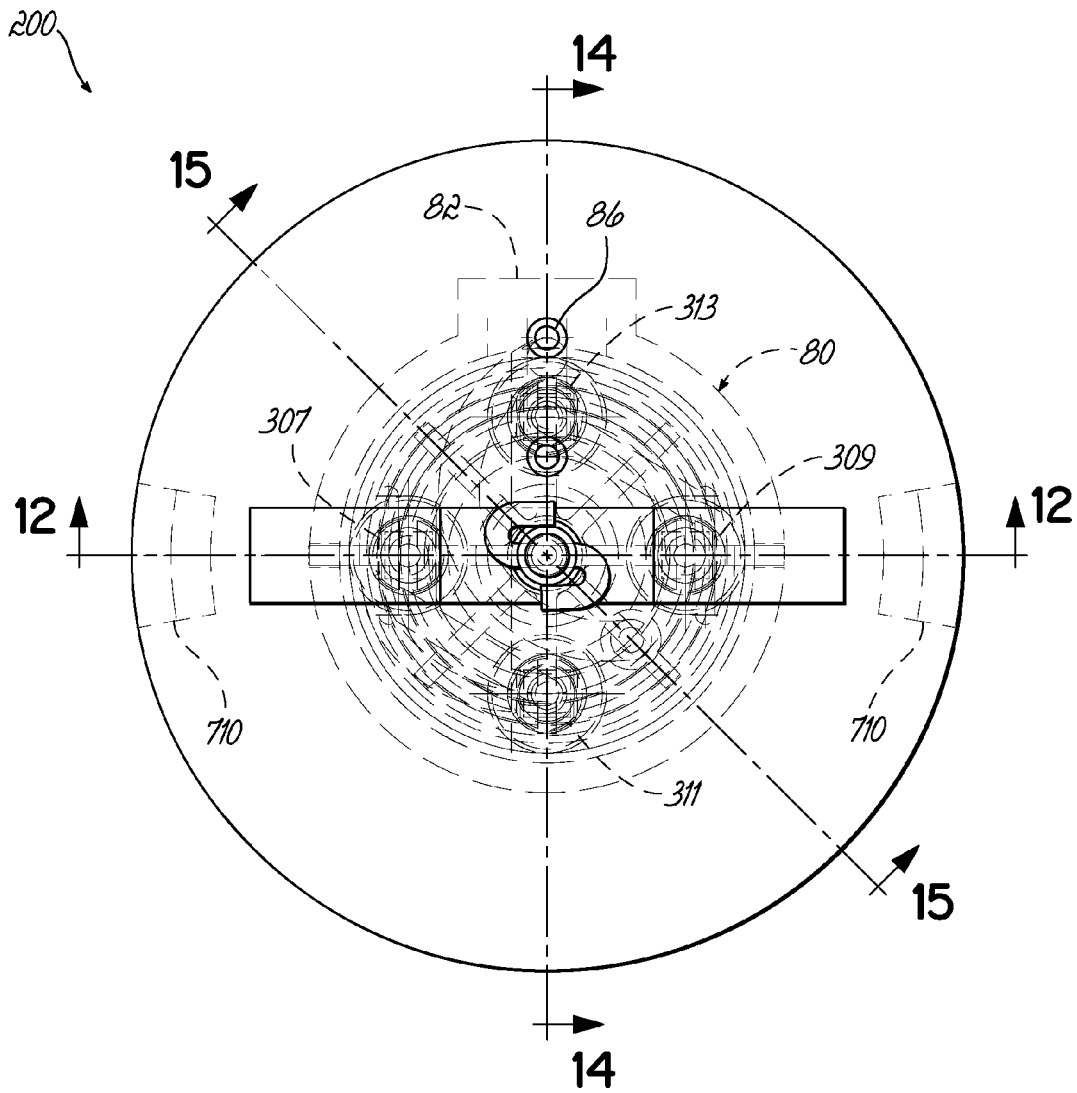

FIG. 13

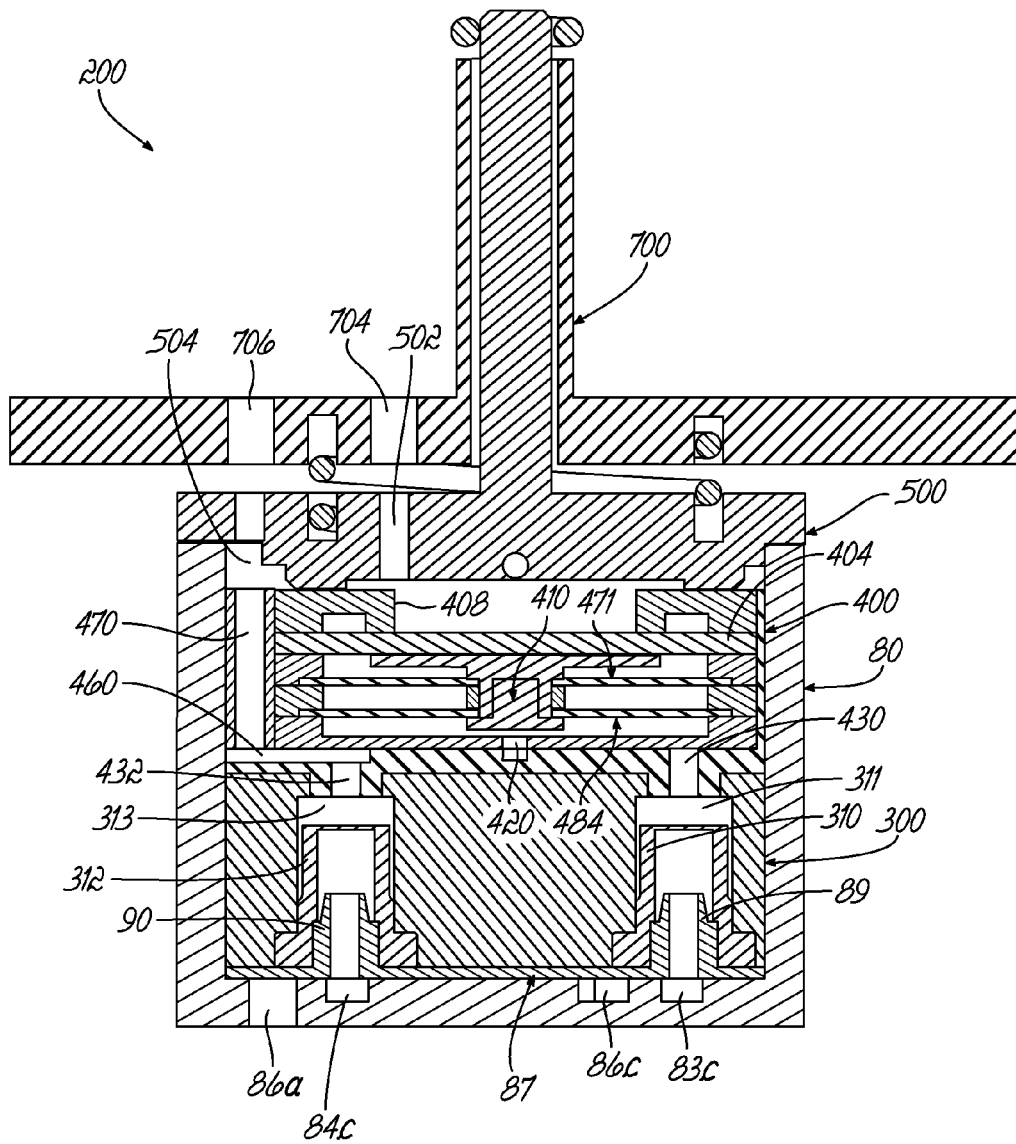

FIG. 14

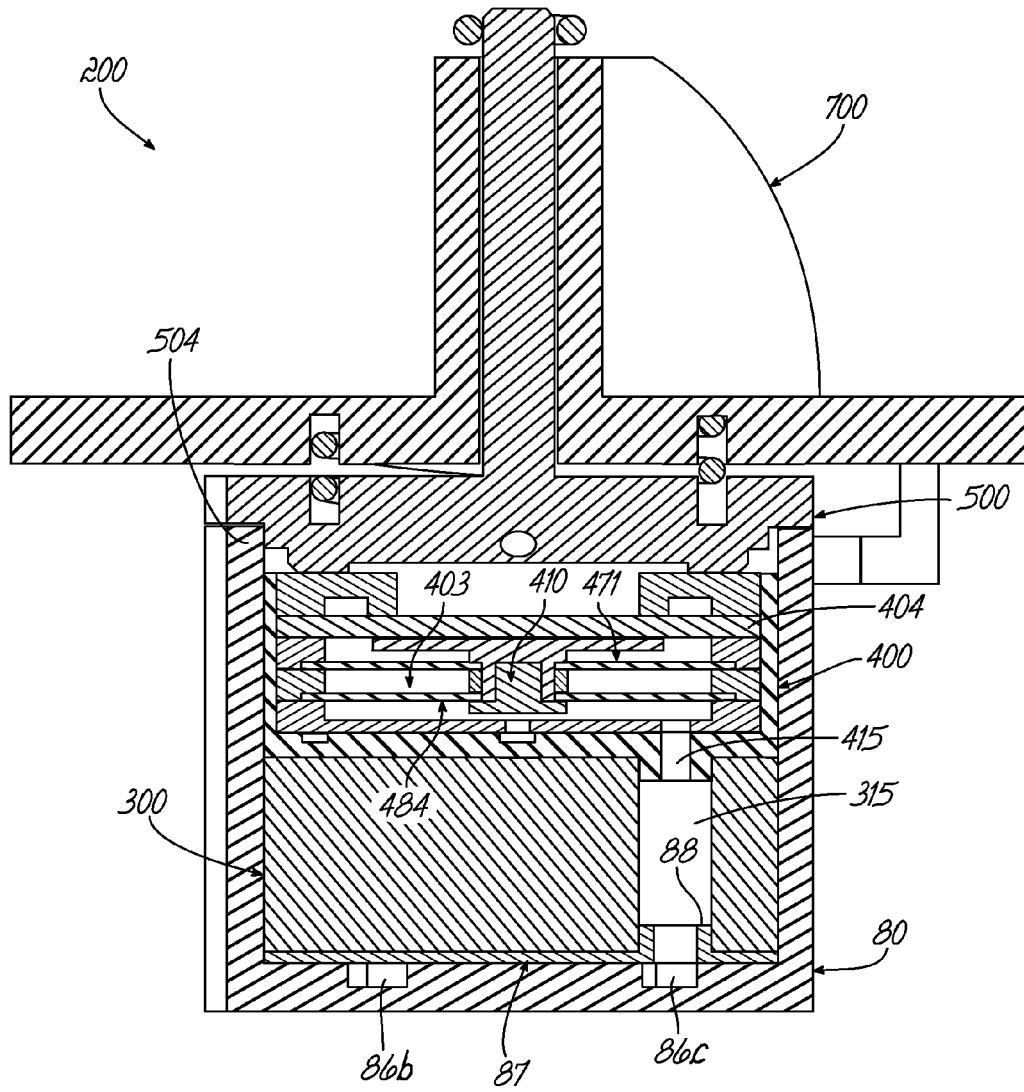

FIG. 15

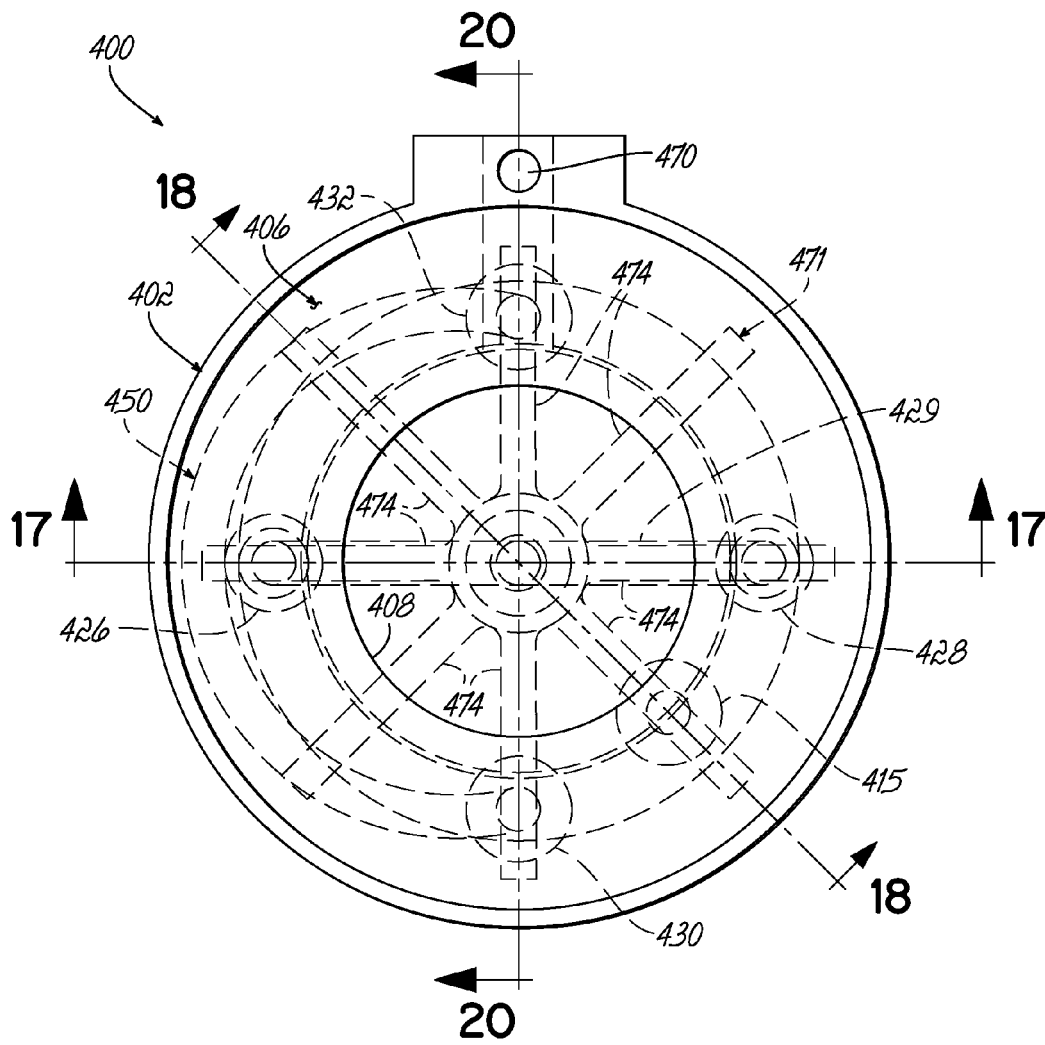

FIG. 16

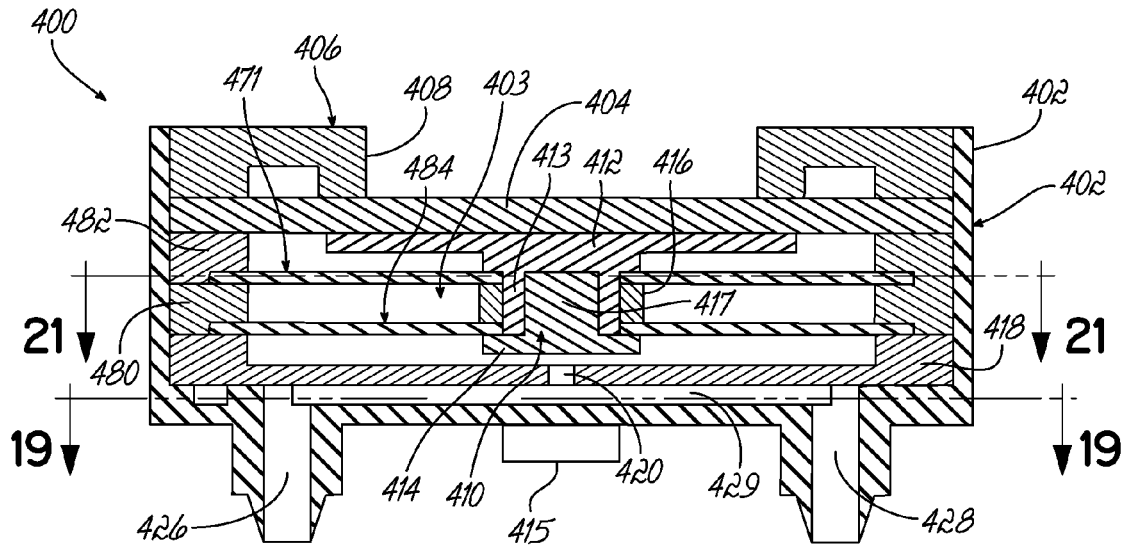

FIG. 17

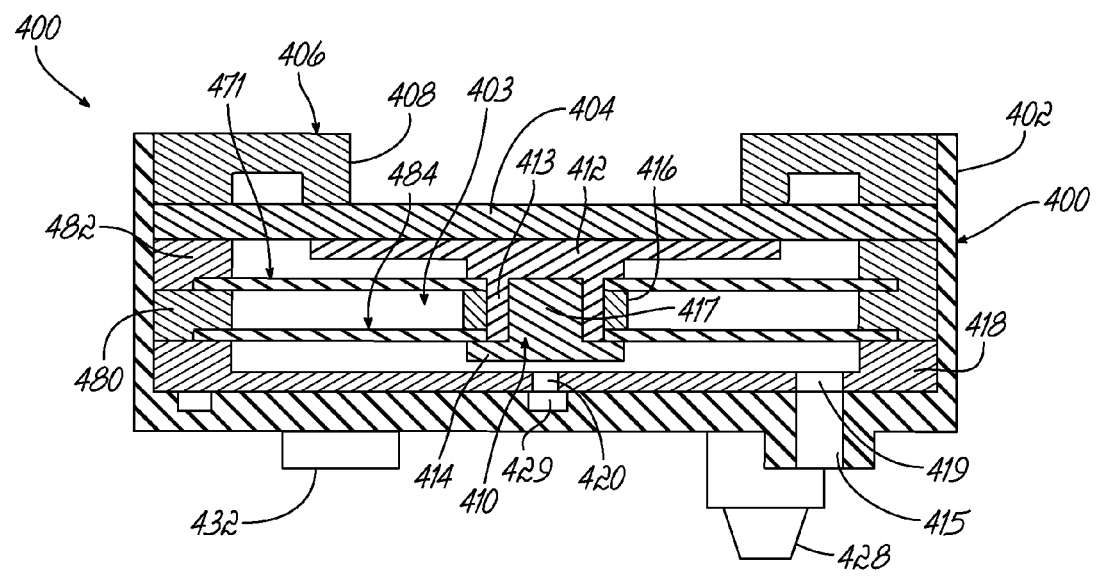

FIG. 18

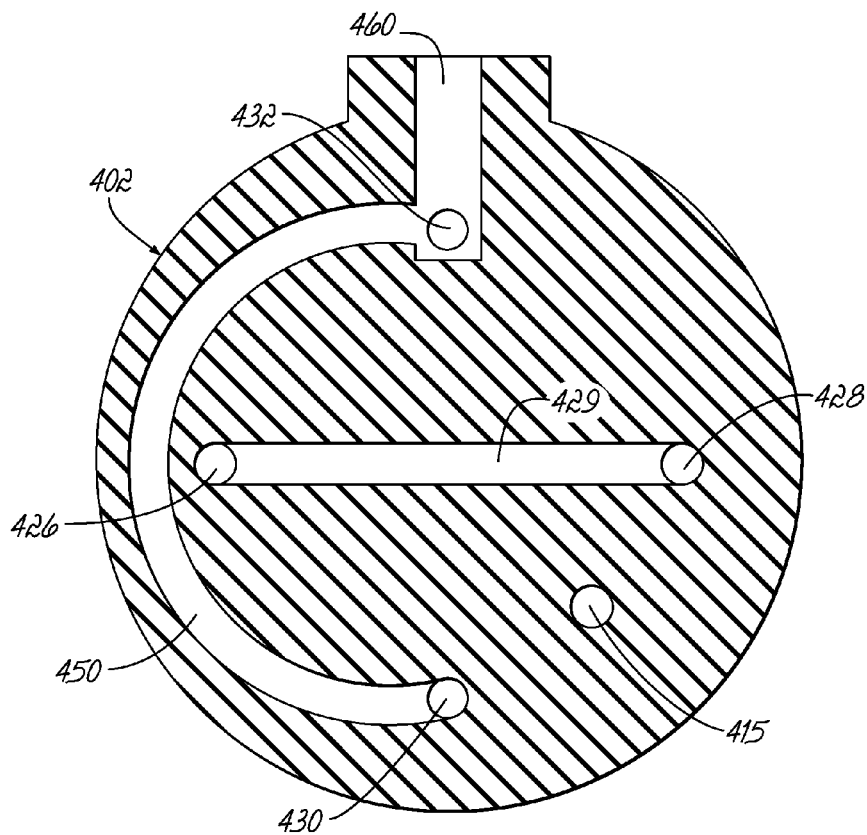

FIG. 19

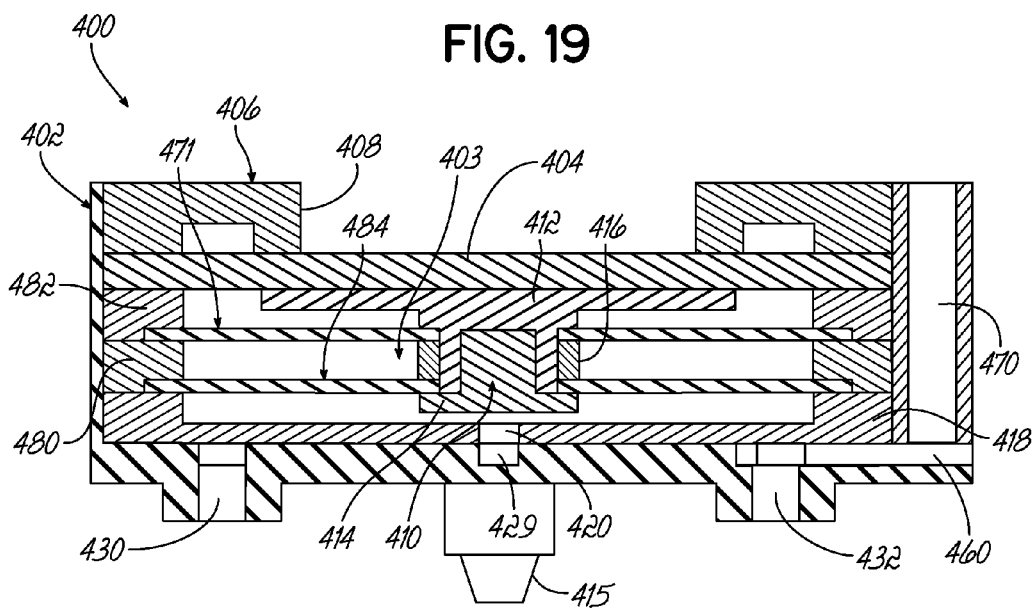

FIG. 20

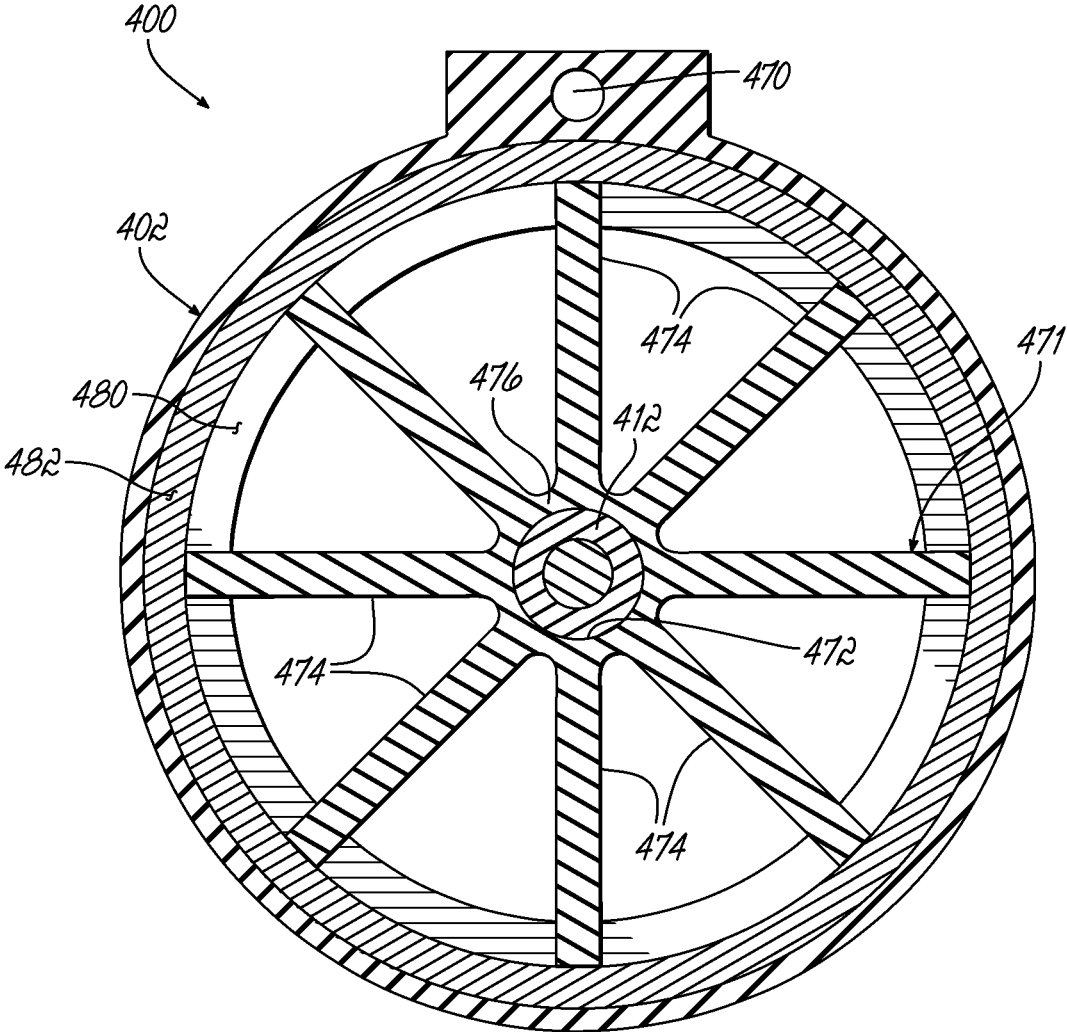

FIG. 21

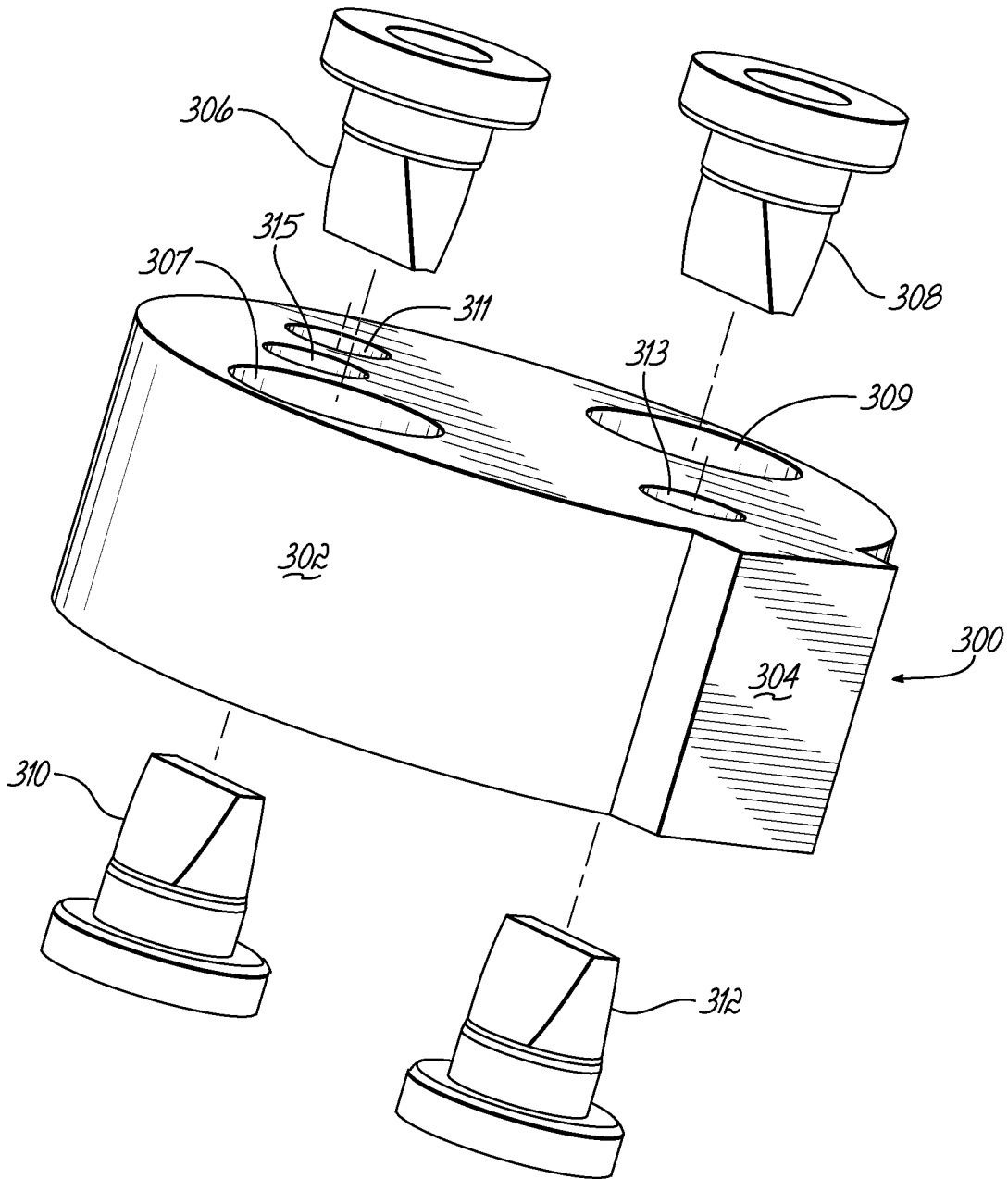

FIG. 22

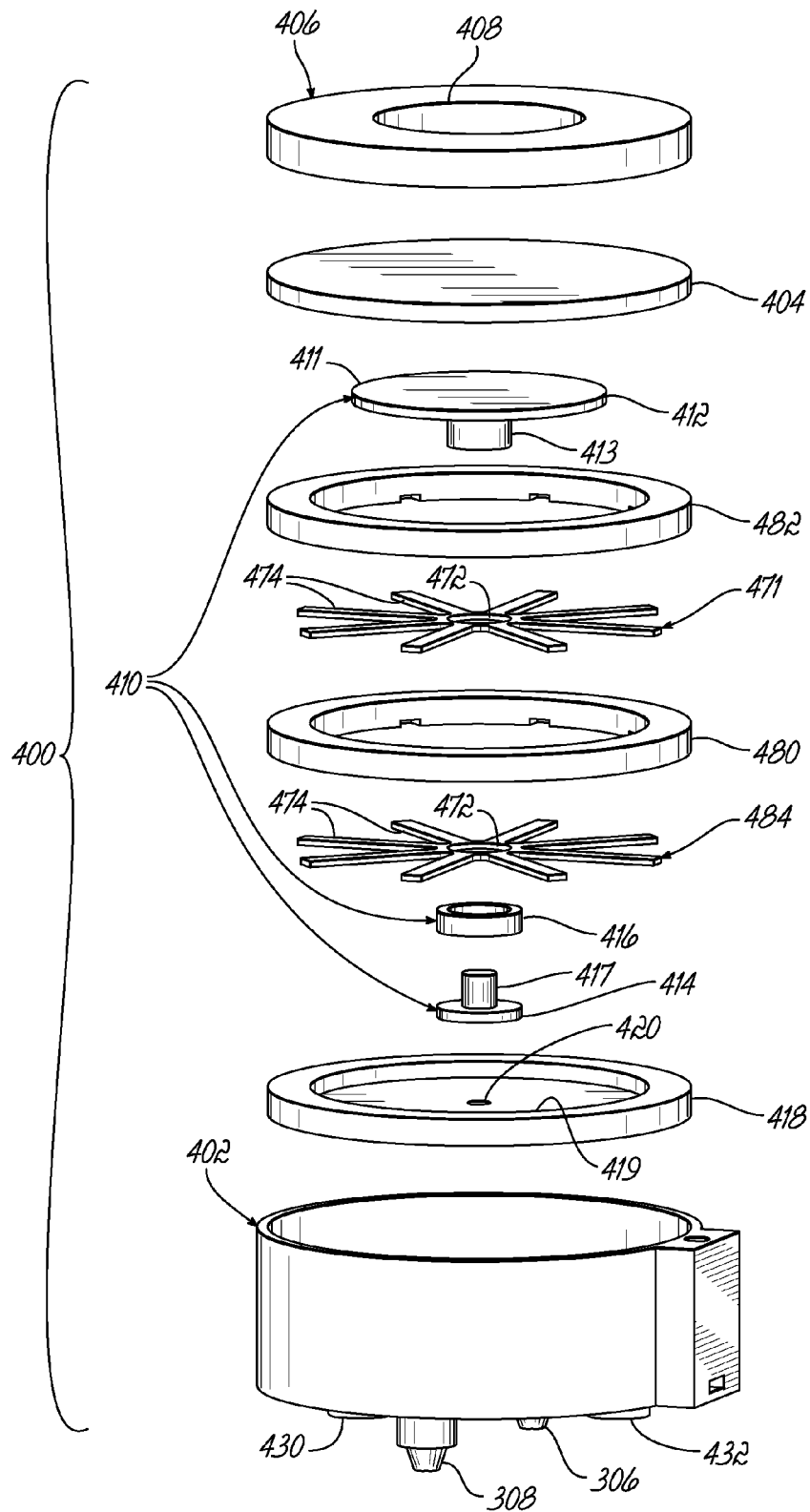

FIG. 23

COMPACT VALVE SYSTEM FOR SELF-INFLATING TIRE

FIELD OF THE INVENTION

[0001] The invention relates generally to self-inflating tires and, more specifically, to a pump mechanism for such tires.

BACKGROUND OF THE INVENTION

[0002] Normal air diffusion reduces tire pressure over time. The natural state of tires is under inflated. Accordingly, drivers must repeatedly act to maintain tire pressures or they will see reduced fuel economy, tire life and reduced vehicle braking and handling performance. Tire Pressure Monitoring Systems have been proposed to warn drivers when tire pressure is significantly low. Such systems, however, remain dependant upon the driver taking remedial action when warned to re-inflate a tire to recommended pressure. It is a desirable, therefore, to incorporate a self-inflating feature within a tire that will self-inflate the tire in order to compensate for any reduction in tire pressure over time without the need for driver intervention.

SUMMARY OF THE INVENTION

[0003] The invention provides in a first aspect a tire having a pump and valve assembly. The tire has a tire cavity, and a first and second sidewall extending respectively from first and second tire bead regions to a tire tread region. The valve assembly has a valve housing, wherein the valve housing has an interior chamber, wherein a diaphragm is mounted in the interior chamber, and wherein the diaphragm is in fluid communication with the tire cavity. The valve housing has a passageway in fluid communication with the tire cavity and the outlet end of the pump. The interior chamber has a chamber inlet in fluid communication with the outside air, and a chamber outlet in fluid communication with an inlet and an outlet of the pump passageway. The valve assembly further including an inlet control valve positioned over the chamber outlet and operative to open and close said chamber outlet. A resilient member is positioned in the interior chamber of the valve housing, and having a first end connected to the inlet control valve.

[0004] The invention provides is a second aspect a tire having a bidirectional pump and valve assembly. The tire has a tire cavity, and a first and second sidewall extending respectively from first and second tire bead regions to a tire tread region. The tire has a pump passageway, said pump passageway having a first end and a second end and being operative to allow a portion of the pump passageway near a tire footprint to close and open the pump passageway when the tire is rotated. The valve assembly having a valve housing having an interior chamber, wherein a diaphragm is mounted in the interior chamber, and wherein the diaphragm is responsive to the pressure of the tire cavity. The interior chamber having an inlet in fluid communication with the outside air, and an outlet in fluid communication with a first chamber and a second chamber. The valve assembly further including an inlet control valve positioned in the interior chamber, wherein the inlet control valve is positioned over the outlet and operative to open and close the outlet. Wherein a resilient member is positioned in the interior chamber of the valve housing, wherein the resilient member is positioned to bias the inlet control valve into the open position. The first chamber has a one way valve positioned therein, and the first chamber is in

fluid communication with the pump passageway first end. The second chamber has a one way valve positioned therein, and the second chamber is in fluid communication with the pump passageway second end. The valve housing further includes a third chamber, wherein the third chamber is in fluid communication with the pump first end and the tire cavity. A one way valve is positioned in the third chamber, wherein the third chamber is located between the pump first end and the tire cavity.

DEFINITIONS

[0005] “Aspect ratio” of the tire means the ratio of its section height (SH) to its section width (SW) multiplied by 100 percent for expression as a percentage.

[0006] “Asymmetric tread” means a tread that has a tread pattern not symmetrical about the center plane or equatorial plane EP of the tire.

[0007] “Axial” and “axially” means lines or directions that are parallel to the axis of rotation of the tire.

[0008] “Chafer” is a narrow strip of material placed around the outside of a tire bead to protect the cord plies from wearing and cutting against the rim and distribute the flexing above the rim.

[0009] “Circumferential” means lines or directions extending along the perimeter of the surface of the annular tread perpendicular to the axial direction.

[0010] “Equatorial Centerplane (CP)” means the plane perpendicular to the tire’s axis of rotation and passing through the center of the tread.

[0011] “Footprint” means the contact patch or area of contact of the tire tread with a flat surface at zero speed and under normal load and pressure.

[0012] “Inboard side” means the side of the tire nearest the vehicle when the tire is mounted on a wheel and the wheel is mounted on the vehicle.

[0013] “Lateral” means an axial direction.

[0014] “Lateral edges” means a line tangent to the axially outermost tread contact patch or footprint as measured under normal load and tire inflation, the lines being parallel to the equatorial centerplane.

[0015] “Net contact area” means the total area of ground contacting tread elements between the lateral edges around the entire circumference of the tread divided by the gross area of the entire tread between the lateral edges.

[0016] “Non-directional tread” means a tread that has no preferred direction of forward travel and is not required to be positioned on a vehicle in a specific wheel position or positions to ensure that the tread pattern is aligned with the preferred direction of travel. Conversely, a directional tread pattern has a preferred direction of travel requiring specific wheel positioning.

[0017] “Outboard side” means the side of the tire farthest away from the vehicle when the tire is mounted on a wheel and the wheel is mounted on the vehicle.

[0018] “Passageway” means an integrally formed pathway in the tire or a discrete tube inserted in the tire forming the pump.

[0019] “Peristaltic” means operating by means of wave-like contractions that propel contained matter, such as air, along pathways.

[0020] “Radial” and “radially” means directions radially toward or away from the axis of rotation of the tire.

[0021] “Rib” means a circumferentially extending strip of rubber on the tread which is defined by at least one circum-

ferential groove and either a second such groove or a lateral edge, the strip being laterally undivided by full-depth grooves.

[0022] “Sipe” means small slots molded into the tread elements of the tire that subdivide the tread surface and improve traction, sipes are generally narrow in width and close in the tires footprint as opposed to grooves that remain open in the tire’s footprint.

[0023] “Tread element” or “traction element” means a rib or a block element defined by having shape adjacent grooves.

[0024] “Tread Arc Width” means the arc length of the tread as measured between the lateral edges of the tread.

BRIEF DESCRIPTION OF THE DRAWINGS

[0025] The invention will be described by way of example and with reference to the accompanying drawings in which:

[0026] FIG. 1 is a front view of a tire and wheel assembly showing a pump and valve assembly;

[0027] FIG. 2 illustrates the tire and wheel assembly of FIG. 1 in operation during tire rotation;

[0028] FIG. 3 is an enlarged cross-sectional view of the bead area of the tire, including the pump;

[0029] FIG. 4 is an enlarged cross-sectional view illustrating the pump being compressed in the tire bead area;

[0030] FIG. 5A is a cross sectional view of the bead area shown with the compact valve system and filter assembly of the present invention;

[0031] FIG. 5B is an enlarged view of the compact valve system of FIG. 5A shown in a plane perpendicular to FIG. 5A;

[0032] FIG. 6 is a side perspective view of the compact valve system as viewed from inside the tire;

[0033] FIG. 7 is a schematic of the compact valve system and pump of the present invention;

[0034] FIG. 8 is a side perspective view of the compact valve system, shown with the insert removed;

[0035] FIG. 9 is an exploded view of the retainer and the upper plate;

[0036] FIG. 10A is a top view of the retainer;

[0037] FIG. 10B is a cross-sectional view of the retainer in the direction 10B-10B of FIG. 10A;

[0038] FIG. 10C is a cross-sectional view of the retainer in the direction 10C-10C of FIG. 10A;

[0039] FIG. 10D is a cross-sectional view of the retainer in the direction 10D-10D of FIG. 10A;

[0040] FIG. 10E is a cross-sectional view of the retainer in the direction 10E-10E of FIG. 10B;

[0041] FIG. 11 is an exploded view of the compact valve system and filter assembly;

[0042] FIG. 12 is a cross-sectional side view of the compact valve system, without the insert, in the direction 12-12 of FIG. 13;

[0043] FIG. 13 is a top view of the compact valve system, without the insert.

[0044] FIG. 14 is a cross-sectional side view of FIG. 13 in the direction 14-14;

[0045] FIG. 15 is a cross-sectional side view of FIG. 14 in the direction 15-15;

[0046] FIG. 16 is a top view of the inlet control valve;

[0047] FIG. 17 is a cross-sectional view of the inlet control valve in the direction 17-17 of FIG. 16;

[0048] FIG. 18 is a cross sectional view of the inlet control valve in the direction 18-18 of FIG. 16.

[0049] FIG. 19 is a cross sectional view of the inlet control valve in the direction 19-19 of FIG. 17;

[0050] FIG. 20 is a section view of the inlet control valve of FIG. 16 in the direction 20-20;

[0051] FIG. 21 is a section view of the inlet control valve of FIG. 17 in the direction 21-21;

[0052] FIG. 22 is an exploded view of the flow controller.

[0053] FIG. 23 is an exploded view of the inlet control valve.

DETAILED DESCRIPTION OF THE INVENTION

[0054] Referring to FIGS. 1 and 3, a tire assembly 10 includes a tire 12, a peristaltic pump assembly 14, and a tire wheel 16. The tire mounts in a conventional fashion to a rim having rim mounting surfaces 18 located adjacent outer rim flanges 22. The outer rim flange 22 has an outer rim surface 26. An annular rim body 28 joins the rim flanges 22 and supports the tire assembly as shown. The tire is of conventional construction, having a pair of sidewalls 32 extending from opposite bead areas 34 to a crown or tire tread region 38. The tire and rim enclose an interior tire cavity 40.

[0055] As shown in FIG. 1 the pump assembly 14 includes a pump passageway 42 that is mounted or located in the sidewall area of the tire, preferably near the bead region. The pump passageway 42 may be formed of a discrete tube made of a resilient, flexible material such as plastic, elastomer or rubber compounds, and is capable of withstanding repeated deformation cycles when the tube is deformed into a flattened condition subject to external force and, upon removal of such force, returns to an original condition. The tube is of a diameter sufficient to operatively pass a volume of air sufficient for the purposes described herein and allowing a positioning of the tube in an operable location within the tire assembly as will be described. Preferably, the tube has an elliptical cross-sectional shape, although other shapes such as round may be utilized.

[0056] The pump passageway itself may also be integrally formed into the sidewall of the tire during vulcanization, eliminating the need for an inserted tube. An integrally formed pump passageway is preferably made by building into a selected green tire component such as a chafer, a removable strip made of wire or silicone. The component is built into the tire and cured. The removable strip is then removed post cure to form a molded in or integrally formed pump air passageway.

[0057] Hereinafter, the term “pump passageway” refers either to installed tubes or an integrally molded in passageway. The location selected for the air passageway within the tire is not limited to the sidewall of the tire, and may be within a tire component residing within a high flex region of the tire, sufficient to progressively collapse the internal hollow air passageway as the tire rotates under load thereby conveying air along the air passageway from the inlet to the pump outlet.

[0058] The pump air passageway 42 has an inlet end 42a and an outlet end 42b joined together by a compact valve system 200. As shown, the inlet end 42a and the outlet end 42b are spaced apart approximately 360 degrees forming an annular pump assembly.

Compact Valve System 200

[0059] A first embodiment of a compact valve system 200 is shown in FIGS. 5-19. FIG. 11 illustrates an exploded view of the compact valve system 200. The compact valve system includes an inlet control valve 400 which functions to regulate and control the inlet flow and exit flow of the pump 42.

Starting from the bottom of the FIG. 11, the compact valve system 200 includes an optional insert 60, a retainer 80, a flow controller 300, an inlet control valve 400 and cap 500, a spring 600, and a lid 700. An optional filter assembly 800 is connected to the compact valve system 200.

Insert 60

[0060] As shown in FIG. 5A, the compact valve system includes an optional insert 60 that is inserted into a receptacle 64 built in the tire. The receptacle 64 is a raised area or hump formed on the tire inner surface and may optionally include a threaded inner hole, wherein the hump may be built into the tire sidewall using a series of concentric layers of material, such as uncured elastomer, green rubber. A one piece molded shape of rubber or elastomer may also be used instead of the concentric layers. Alternatively, the insert 60 may be inserted into the receptacle prior to vulcanization. The outer insert may be made of green rubber, elastomer, nylon, ultra high molecular weight polyethylene or metal such as brass. The insert is preferably coated with a suitable adhesive such as resorcinol formaldehyde latex (RFL) or commonly referred to as "dip" known to those skilled in the art. The outer surface of the insert may be roughened and coated with the selected RFL. The outer surface of the insert may further include ridges, flanges, extensions, threads or other mechanical means in addition to the selected RFL to retain the insert into the rubber of the tire sidewall.

[0061] As shown in FIG. 5B, the optional insert 60 is shaped like a cup and has an interior section formed by an open end facing the tire cavity, a bottom wall 62 opposite the open end and a sidewall 63. The bottom wall has two male portions 65 and 67 extending from the bottom wall that align and connect to the pump passageways 42a, 42b for communicating fluid between the insert 60 and pump 42. Each male portion has a hole therethrough for communicating air to the interior of the valve. The bottom portion also has two opposed holes 68, 69 for alignment and fluid communication with the pump passageways 42a, 42b. An optional gasket 70 is positioned on the bottom wall 62 of the insert 60. The gasket is circular and flat, with holes aligned with the holes 68, 69 of the insert 60. The gasket may also have protruding rims around the three holes. As shown in FIG. 5A, the bottom wall 62 of the insert 60 has a third hole 71 for receiving the male portion 820 of the filter assembly 800. The outer insert 60 also has a flanged rim portion 61 that surrounds the sidewall 63 with opposed female slots. A lid 700 with two opposed U shaped connectors 710 are received within opposed female slots.

Retainer 80

[0062] The optional outer insert 60 houses a retainer 80. The retainer 80 is shown in FIGS. 8-9 and FIGS. 10A-E. The retainer 80 is generally cylindrically shaped, with an alignment key 82 projecting from the outer surface. The alignment key 82 is seated in mating engagement with an alignment slot (not shown) formed in the sidewall of the outer insert 60. The alignment key 82 ensure that slots 83a, 84a on the bottom surface 85 of the valve body aligns with holes 68, 69 of the insert. The bottom surface 85 of the retainer further includes a hole 86 for receiving filtered air from the filter assembly 800. The insert 60 is an optional component that may be eliminated, and the outer surface of the retainer 80 may be threaded for reception into the receptacle 64.

[0063] FIG. 9 illustrated an exploded view of the retainer 80 wherein an upper plate 87 is positioned over the bottom surface 81, so that an alignment tab 91 is received in the alignment key 82 of the retainer 80. FIG. 10E illustrates a cross-sectional view of the bottom of the retainer 80. As shown in FIG. 10A, the bottom surface 81 of the retainer has grooves formed therein, which cooperate with the upper plate to form passageways 83b, 86b, and 84b. Fluid from the pump enters slotted holes 83a, 84a and then are communicated through angled passageways 83b, 84b to locations 83c, 84c. As shown in FIG. 10C, flow from location 83c, 84c is then directed through port 89, 90 of upper plate 87. As shown in FIG. 10B, the upper plate 87 has opposed slots 92, 93 positioned for alignment with slots 83a, 84a. As shown in FIG. 10C, inlet flow from the filter enters the retainer through hole 86a, which is then routed through angled channel 86b into location 86c. As shown in FIG. 10D, flow from location 86c is then ported through hole 88 of the upper plate 87.

[0064] As shown in FIG. 11, a flow controller 300 is positioned inside the retainer 80. As shown in FIG. 22, the flow controller body 302 has an alignment tab 304 positioned for reception in the alignment key 82 of the retainer. The flow controller 300 has directional control valves 306, 308 and anti return or check valves 310, 312.

Inlet Control Valve

[0065] As shown in FIG. 11, an inlet control valve 400 is positioned inside the retainer 80 and adjacent to the flow controller 300. The inlet control valve 400 regulates the intake flow to the pump system. As shown in FIG. 17, the inlet control valve has a housing 402 for housing a circular shaped diaphragm 404. The housing 402 has two aligned holes in a first direction on the bottom surface: first and second passageways 426, 428, which are joined together by elongate slot 429. The elongate slot 429 is formed in the bottom of the housing 402, as shown in FIG. 19. As shown in FIG. 12, each first and second passageway 426, 428 aligns with chamber 307, 309 respectively of the flow controller 300. As shown in FIG. 20, the inlet control housing 402 also has two aligned holes on the bottom surface in a second direction, perpendicular to the first direction: third passageway 430 and fourth passageway 432. As shown in FIG. 19, third passageway 430 and fourth passageway 432 are in fluid communication by C shaped slot 450 formed in the inlet housing 402. The curved slot 450 routs flow from passageway 430 to channel 460 and then through outlet channel 470.

[0066] As shown in FIG. 17, the interior of the housing 402 has a central chamber 403. A bottom plate 418 is positioned on the bottom of the central chamber 403. The bottom plate 418 has a central hole 420 for fluid communication with the elongate slot 429. As shown in FIG. 20, the bottom plate 418 blocks flow from passageways 430, 432 into the inlet control valve housing. As shown in FIG. 18, the bottom plate 418 allows flow into the inlet control valve from passageway 415 via hole 419. Filtered inlet air is routed through inlet hole 86a/b/c of the retainer, through chamber 315 of the flow controller, and then through hole 415 of the inlet control housing 402, and then through hole 419 of the bottom plate 418 into the inlet chamber of the control valve.

[0067] As shown in FIG. 17, positioned adjacent the bottom plate 418 is an inlet control valve 410. As best shown in FIG. 23, the inlet control valve 410 is formed of the valve bottom 414, an optional spacer 416 and a valve top 412. The valve top 412 has a circular planar region having a first side

411 positioned adjacent a circular diaphragm **404**, and a second side having a central collar **413** extending therefrom. An optional spacer **416** may be received about the collar **413**. The valve bottom **414** has a plug **417** extending therefrom which is received inside the collar **413**. The valve bottom **414** is positioned to be seated over valve seat hole **420** of the bottom plate **418**, and positioned to block flow from entering valve seat hole **420**.

[0068] A first elastic member **471** has an inner hole **472** that is positioned between the spacer **416** and the valve top **412**. The first elastic member **471** has a plurality of spokes **474** which extend radially from an annular member **476**. The outer ends **478** of the spokes are received between two annular spacers **480**, **482**. An optional second elastic member **484** may have the outer radial ends received between the annular spacer **480** and the bottom plate **418**. The inner portion of the optional second elastic member **484** may be received between the valve bottom and the spacer **416**. The first and second elastic members **471**, **484** are formed of a resilient material such as metal, rubber, elastomer to function as a spring.

[0069] The advantage to this design is that the outside air enters the interior valve chamber, and then is sucked through the valve seat hole and then to the pump. Thus the vacuum force is acting on a relatively small hole **420** versus the entire diaphragm. Thus the elastic members **471**, **484** do not have to overcome a large vacuum force.

[0070] The inlet control valve further includes an optional cover **406** having a hole **408** that is positioned over the diaphragm **404**. The diaphragm **404** is positioned adjacent valve body **411**. As shown in FIG. 11, an inner cap **500** is positioned over the inlet control valve. As shown in FIG. 15, the inner cap has an interior hole **502** to allow fluid communication of the diaphragm with the inside cavity of the tire. The cap has a second hole **504** that is in fluid communication with the passageway **470**. A lid **700** is received over the inner cap **500**. A spring **600** is positioned between the lid **700** and the inner cap **500**. The inner cap **500** has a central support column **510** which is received in a central hole **702** of outer cap. The outer cap has aligned holes **704**, **706** with holes **502**, **504**. A lid **700** with two opposed U shaped connectors **710** are received within opposed female slots of the outer insert **60**.

[0071] FIG. 7 illustrates a schematic of the tire assembly **10** including the flow controller and its relation to the pump **42** and inlet control valve **400**. The inlet control valve **400** controls whether outside filtered air is permitted to enter the system. If air is needed, the inlet control valve **400** opens and allows air to enter the interior chamber **403** of the inlet control valve **400**. Air is sucked through the hole **420**, into slot **429**, through directional control valve **308** and then into the pump. Flow is directed through the flow controller **300**, and through one of directional control valve **308**. Flow enters the pump inlet **42a** and is pumped through the tire to the pump outlet **42b**. The anti return or check valve **306** blocks the pumped flow from entering inlet control valve. The pumped air passes through check valve **310** and then into the tire cavity. If the tire is rotating in the opposite direction, air enters through directional valve **306**, is directed into the pump **42b** and then into anti return valve **312** and then into tire cavity.

Filter Assembly

[0072] The filter assembly **800** is configured to be mounted on the outside of the tire. The filter assembly is shown having a circular cross-sectional shape with a hard plastic exterior that is shown mounted in the lower sidewall area near the

bead. The filter assembly **800** has an interior section **802** filled with porous media **804** suitable for filtering air. The filter assembly **800** has an inlet **810** to receive ambient air. Air travels through the inlet **810** and into the interior section **802** where the air is filtered by the porous media **804**. The air exits the outlet **812** of the interior section and into passageway **814** that extends through a male fitting **816**. The male fitting **816** is aligned for connection with aligned holes **86** of the retainer and hole **86a** of the insert.

System Operation

[0073] The compact valve system **200** controls the flow of air into the pump system. As shown in FIGS. 6 and 14, the tire cavity pressure is communicated to the diaphragm **404** via holes **704**, **502**, **408**. As shown in FIG. 12, the tire cavity pressure acts on the diaphragm **404**, which seats the valve bottom against the central hole **420** so that no air can enter into the compact valve system. The first and second resilient member **471**, **484** counteracts the tire cavity pressure, acting as a spring to bias the valve bottom in the open position. The resilient members are designed to have a set trigger pressure, so that if the tire cavity pressure falls below the trigger pressure, the resilient member(s) bias the valve bottom away from the central hole **420** into the open position. As shown in FIG. 14, filtered outside air enters the compact valve system **200** via hole **86a**.

[0074] After the air enters the compact valve system **200** via hole **86a**, the filtered air is routed through angled channel **86b** into location **86c** of the retainer **80** as shown in FIGS. 10E and 10D. Flow from location **86c** of the retainer is then routed to hole **88** and then into chamber **315** of the flow controller **300** as shown in FIG. 15. Air passes through hole **415** of the inlet control valve and into the inlet control valve interior chamber **403**, as shown in FIGS. 15, 18. The air then passes from the interior chamber **403** into the bottom plate hole **420** if the valve is open. Next the flow is routed to the pump through elongated slot **429**, through directional control valve **306** and into chamber **307**. The flow exits hole **83a** of the retainer and into the pump end **42a**. The air is pumped through the pump passageway **42** as the tire rotates in a first direction.

[0075] As will be appreciated from FIG. 2, air pump **42** is shown as a 360 degree pump, with the inlet **42a** and outlet **42b** co-located. As the tire rotates in a direction **109**, a footprint **100** is formed against the ground surface. A compressive force **104** is directed into the tire from the footprint **100** and acts to flatten a segment **110** of the pump **42** as shown at numeral **106**. Flattening of the segment **110** of the pump **42** forces a portion of air located between the flattened segment **110** and the compact valve system **200**, towards the compact valve system **200**. As the tire continues to rotate in direction **108** along the ground surface **98**, the pump tube **42** will be sequentially flattened or squeezed segment by segment **110**, **110'**, **110''** in a direction opposite to the tire rotation **108**. The sequential flattening of the pump tube **42** segment by segment causes the column of air located between the flattened segments to be pumped to the pump outlet **42b**.

[0076] The pumped air from outlet **42b** enters the compact valve system **200** via slot **84a**. The check valve **308** blocks flow from entering chamber **309**. The pumped air travels from slot **84a** through channel **84b** to port **84c** as shown in FIG. 10E. The pumped air flows from location **84c** is then directed through port **90** of upper plate **87** as shown in FIG. 10c. As shown in FIG. 14, the pumped air flows through check valve **312** into chamber **313**, and then exits the inlet control valve

via fourth passageway **432** of inlet control housing **402**, through channel **460** connected to outlet **470** of the inlet control valve, and then through aligned holes **504** of inner cap and **706** of lid into the tire cavity. The tire will be pumped with air from the pump and inlet control valve assembly **200** until the tire pressure exceeds the trigger pressure. If the tire pressure exceeds the trigger pressure, the valve bottom will seat over central hole **420**, and block air from entering the pump system.

[0077] If the direction of the tire rotation is reversed, the pump and inlet control valve system will work as described above except for the following differences. Filtered air will enter the system into the inlet control valve chamber **403**. If the tire cavity needs air, the valve bottom will unseat from hole **420**. The pumps will suck air from elongated slot **429** and then enter through check valve **308** into chamber **309** and then exit through hole **84a** into pump **42b**. The pumped air will enter the compact valve system **200** through hole **83a**. The check valve **306** will block the flow from entering chamber **307**. The retainer will channel the pumped air through channel **83b** into hole **83c** as shown in FIG. **10E**. As shown in FIG. **14**, from location **83c** the pumped air passes through port **89** of retainer, through directional valve **310** into chamber **311** and into passageway **430** of the inlet control housing **402**. Flow from passageway **430** is routed via curved slot **450** formed in the inlet control housing to channel **460** as shown in FIG. **19**. Flow exits into the cavity via aligned holes **470**, **504**, **706**.

[0078] As described above, the pump assembly may be positioned in the tire sidewall, radially outward of the rim flange surface **26** in the chafer **120**. So positioned, the air tube **42** is radially inward from the tire footprint **100** and is thus positioned to be flattened by forces directed from the tire footprint as described above. The segment that is opposite the footprint **100** will flatten from the compressive force **106** from the footprint **100** pressing the tube segment against the rim flange surface **26**. Although the positioning of the tube **42** is specifically shown as between a chafer **120** of the tire at the bead region **34** and the rim surface **26**, it is not limited to same, and may be located at any region which undergoes compression, such as anywhere in the sidewall or tread.

[0079] From the forgoing, it will be appreciated that the subject invention may be used with a secondary tire pressure monitoring system (TPMS) (not shown) of conventional configuration that serves as a system fault detector. The TPMS may be used to detect any fault in the self-inflation system of the tire assembly and alert the user of such a condition.

[0080] Variations in the present invention are possible in light of the description of it provided herein. While certain representative embodiments and details have been shown for the purpose of illustrating the subject invention, it will be apparent to those skilled in this art that various changes and modifications can be made therein without departing from the scope of the subject invention. It is, therefore, to be understood that changes can be made in the particular embodiments described which will be within the full intended scope of the invention as defined by the following appended claims.

What is claimed is:

1. A tire having a pump and valve assembly comprising:

- a. the tire having a tire cavity, and a first and second sidewall extending respectively from first and second tire bead regions to a tire tread region;
- b. the valve assembly having a valve housing, wherein the valve housing has an interior chamber, wherein a dia-

phragm is mounted in the interior chamber, and wherein the diaphragm is in fluid communication with the tire cavity;

- c. said valve housing having a passageway in fluid communication with the tire cavity and the outlet end of the pump,
 - d. said interior chamber having an inlet in fluid communication with the outside air, and an outlet in fluid communication with an inlet and an outlet of the pump passageway,
 - e. said valve assembly further including an inlet control valve positioned over the outlet and operative to open and close said outlet;
 - f. wherein a resilient member is positioned in the interior chamber of the valve housing, and positioned to bias the inlet control valve into the open position.
- 2.** The tire of claim **1** wherein the resilient member has a first end connected to the inlet control valve.
 - 3.** The tire of claim **1** wherein the inlet control valve has a first end connected to the diaphragm.
 - 4.** The tire of claim **1** wherein the resilient member has an inner hub, and a plurality of spokes which extend radially from the hub.
 - 5.** The tire of claim **2** wherein the inner hub is connected to the inlet control valve.
 - 6.** The tire of claim **2** wherein the inner hub is connected to the inlet control valve bottom.
 - 7.** The tire of claim **1** wherein a one way valve is positioned between the outlet of the interior chamber and the inlet end of the pump passageway.
 - 8.** The tire of claim **1** wherein a one way valve is positioned between the pump outlet end and the passageway in the valve housing.
 - 9.** The tire of claim **1** wherein a filter assembly is in fluid communication with the outside air.
 - 10.** The tire of claim **1** wherein the inlet control valve further includes a second resilient member.
 - 11.** The tire of claim **1** wherein the resilient member is made of metal.
 - 12.** A tire having a bidirectional pump and valve assembly comprising:
 - a. the tire having a tire cavity, and a first and second sidewall extending respectively from first and second tire bead regions to a tire tread region;
 - b. said tire having a pump passageway, said pump passageway having a first end and a second end and being operative to allow a portion of the pump passageway near a tire footprint to substantially close and open the pump passageway when the tire is rotated in a first direction or second direction opposite said first direction,
 - c. the valve assembly having a valve housing, wherein a diaphragm is mounted in the valve housing forming an interior chamber, and wherein the diaphragm is responsive to the pressure of the tire cavity;
 - d. said interior chamber having an inlet in fluid communication with the outside air, and an outlet in fluid communication with a first chamber and a second chamber;
 - e. said valve assembly further including an inlet control valve positioned in the interior chamber, wherein the inlet control valve is positioned over the outlet and operative to open and close the outlet;
 - f. wherein a resilient member is positioned in the interior chamber of the valve housing, and being connected to

- the inlet control valve, wherein the resilient member biases the inlet control valve into the open position;
 - g. Wherein said first chamber has a one way valve positioned therein, and said first chamber is in fluid communication with the pump passageway first end;
 - h. Wherein said second chamber has a one way valve positioned therein, and said second chamber is in fluid communication with the pump passageway second end;
 - i. Wherein the valve housing further includes a third chamber, wherein the third chamber is in fluid communication with the pump first end and the tire cavity;
 - j. Wherein a one way valve is positioned in the third chamber, wherein the third chamber is located between the pump first end and the tire cavity.
- 13.** The tire of claim **12** wherein the valve housing has a fourth chamber, wherein said fourth chamber is in fluid communication with the tire cavity and a pump passageway first end, and said fourth chamber has a one way valve positioned therein.

- 14.** The tire of claim **12** wherein the inlet control valve is connected to the diaphragm.
- 15.** The tire of claim **12** wherein the one way valve of the first chamber prevents flow from entering the interior chamber.
- 16.** The tire of claim **12** wherein the one way valve of the second chamber prevents flow from entering the interior chamber.
- 17.** The tire of claim **12** wherein the one way valve of the third chamber prevents flow from the tire cavity from entering the pump passageway.
- 18.** The tire of claim **12** wherein the one way valve of the fourth chamber prevents flow from the tire cavity from entering the pump passageway.
- 19.** The tire of claim **12** wherein a filter is positioned between the outside air and the third hole.
- 20.** The tire of claim **12** wherein the valve housing has a channel which routes flow from an outlet of the third chamber to an outlet of the fourth chamber.

* * * * *