



(19) **United States**

(12) **Patent Application Publication**
Hinque et al.

(10) **Pub. No.: US 2012/0241064 A1**

(43) **Pub. Date: Sep. 27, 2012**

(54) **HYDRAULIC MEMBRANE PUMP ASSEMBLY FOR AIR MAINTENANCE TIRE**

(76) Inventors: **Daniel Paul Luc Marie Hinque**,
Habay-la-Neuve (BE); **Olivier Di Prizio**, Hettange-Grande (FR)

(21) Appl. No.: **13/069,517**

(22) Filed: **Mar. 23, 2011**

Publication Classification

(51) **Int. Cl.**
B60C 23/12 (2006.01)

(52) **U.S. Cl.** **152/418**

(57) **ABSTRACT**

An air-maintenance tire system includes a compression actuator mounted to the tire carcass configured for operative actuation by tire deformation during a tire revolution, a pump assembly affixed to the tire carcass and including a compres-

sor body affixed to the compression actuator and having an internal air chamber, the air chamber having an inlet opening for admitting air into the internal air chamber and an outlet opening for conducting air from the internal air chamber to the tire cavity. The air compressor body further includes a deformable membrane valve member and an outlet valve member located within and at opposite respective ends of the internal air chamber, the membrane valve member deforming and the outlet valve member moving within the internal air chamber responsive to actuation by the compression actuator between respective open and closed positions, whereby cyclically opening and closing the inlet and the outlet openings during an air compression cycle. The compression actuator includes a hollow containment body formed from a resilient deformable material composition and containing a quantity of a non-compressible medium. The containment body is affixed to a relatively high flex-deformation region of the tire carcass and reciprocally transforms between a deformed state and a non-deformed state to generate a deformation force against a membrane valve member surface and deform the membrane valve between the open and closed positions within the air chamber.

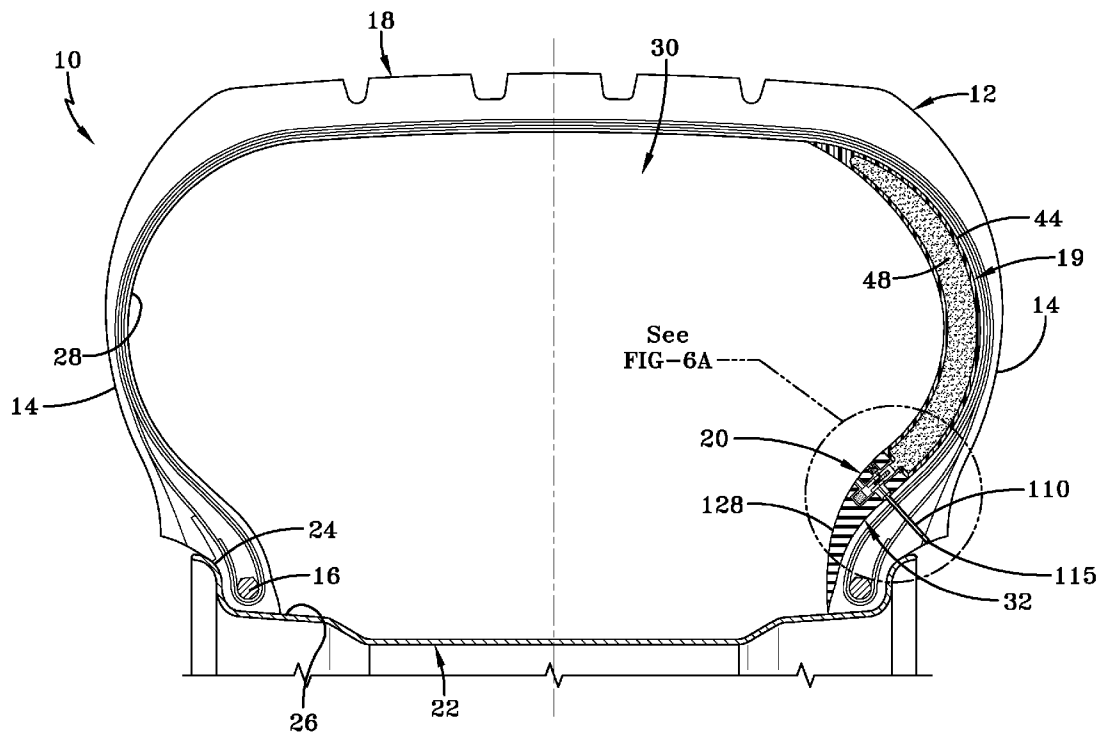

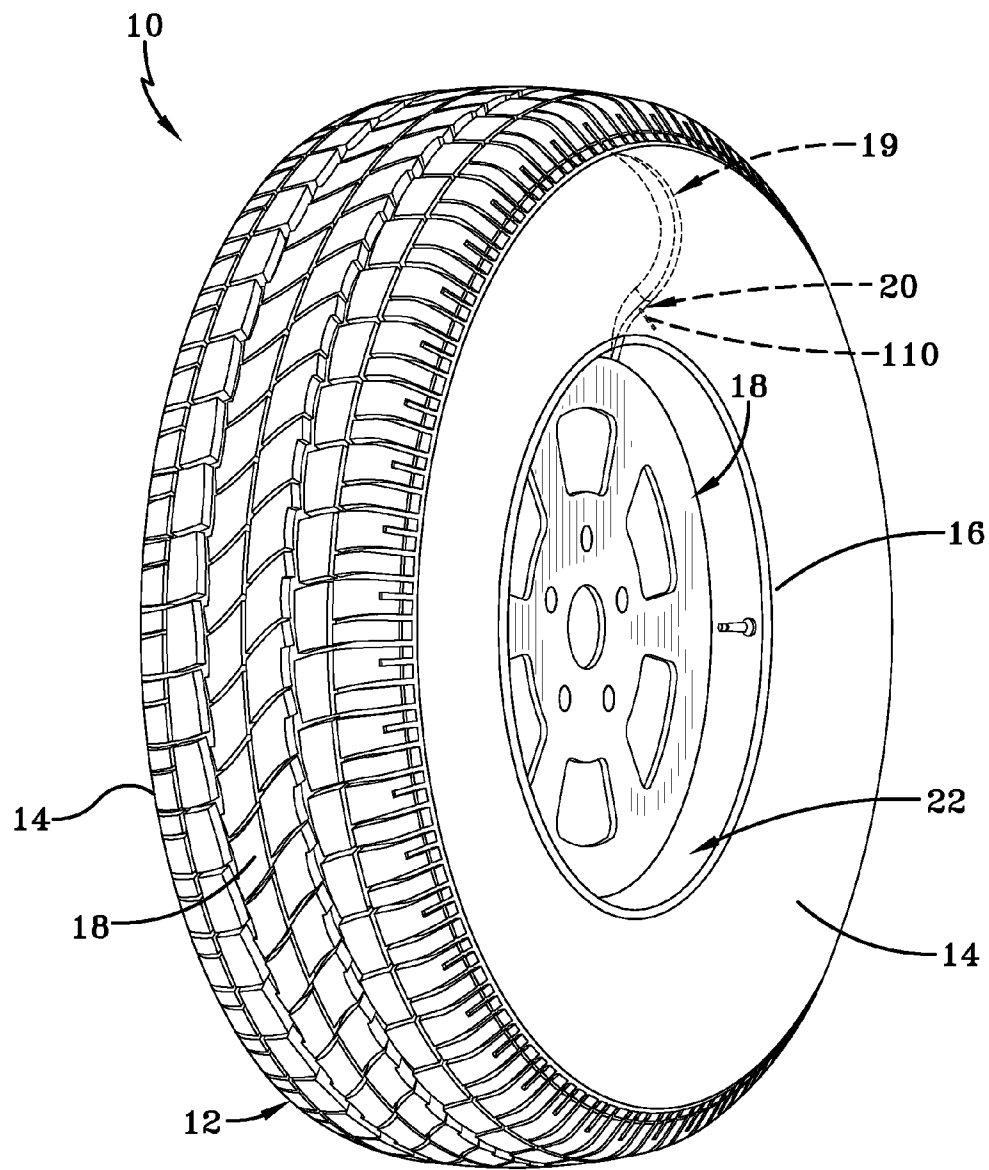

FIG-1

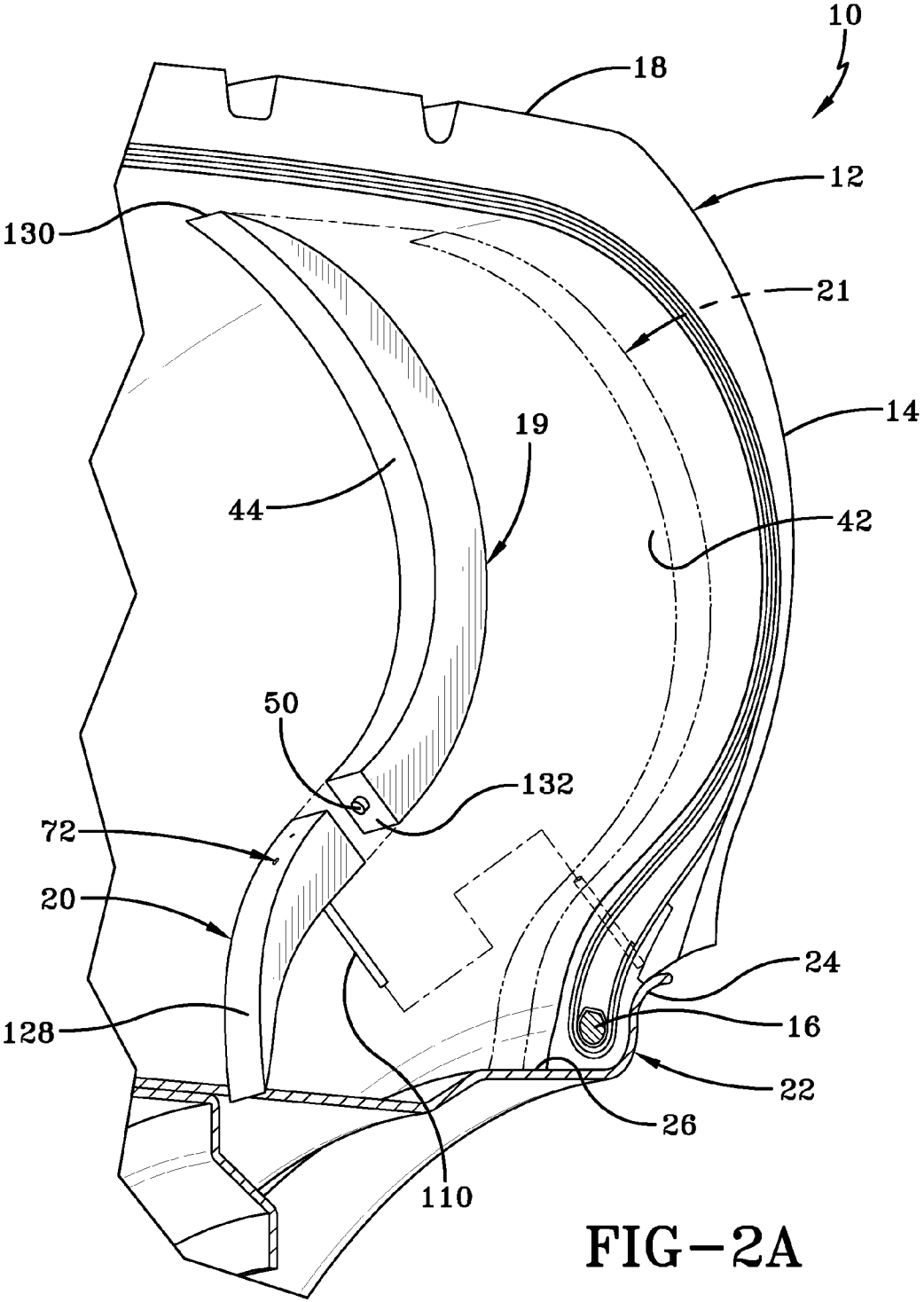

FIG-2A

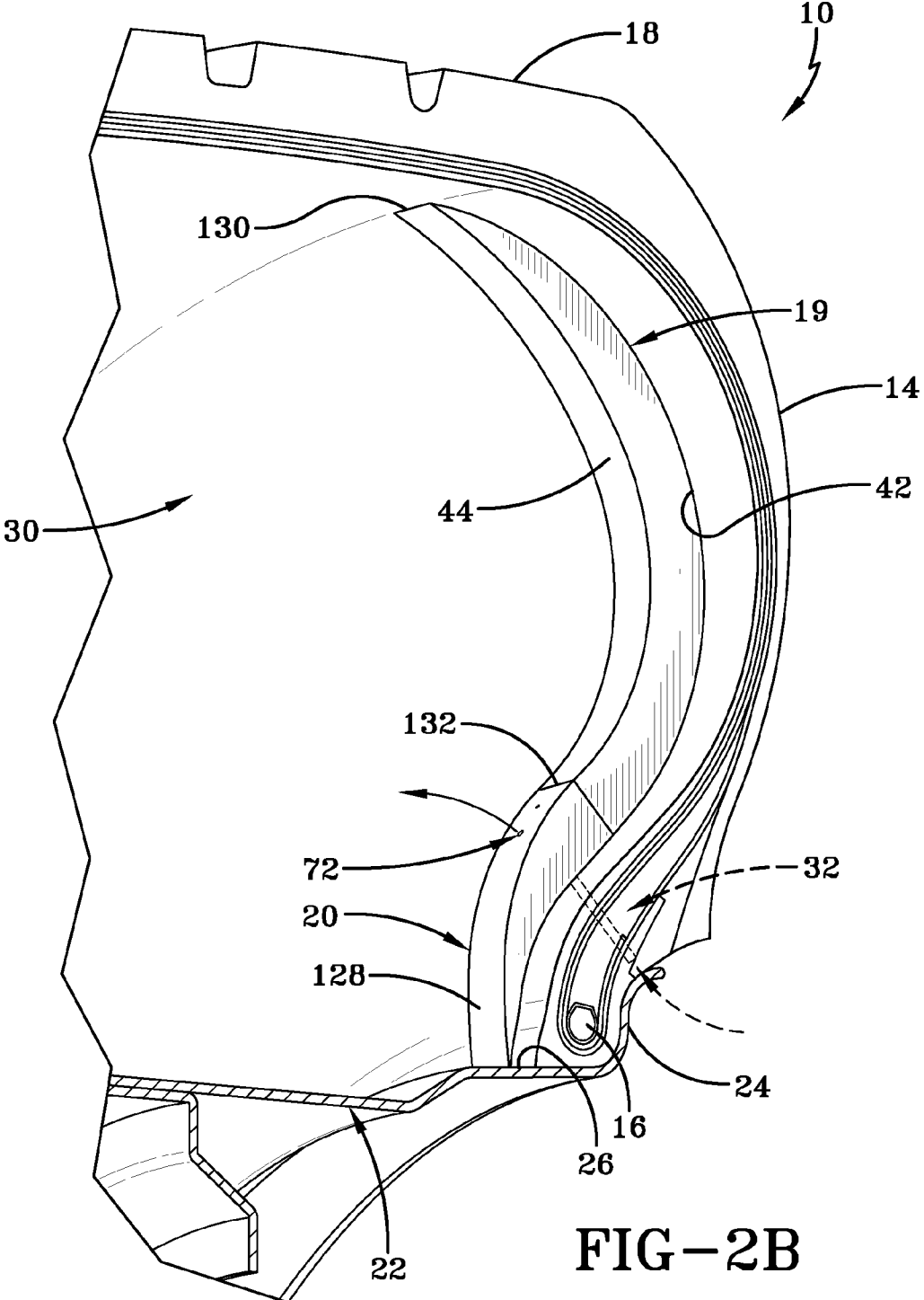

FIG-2B

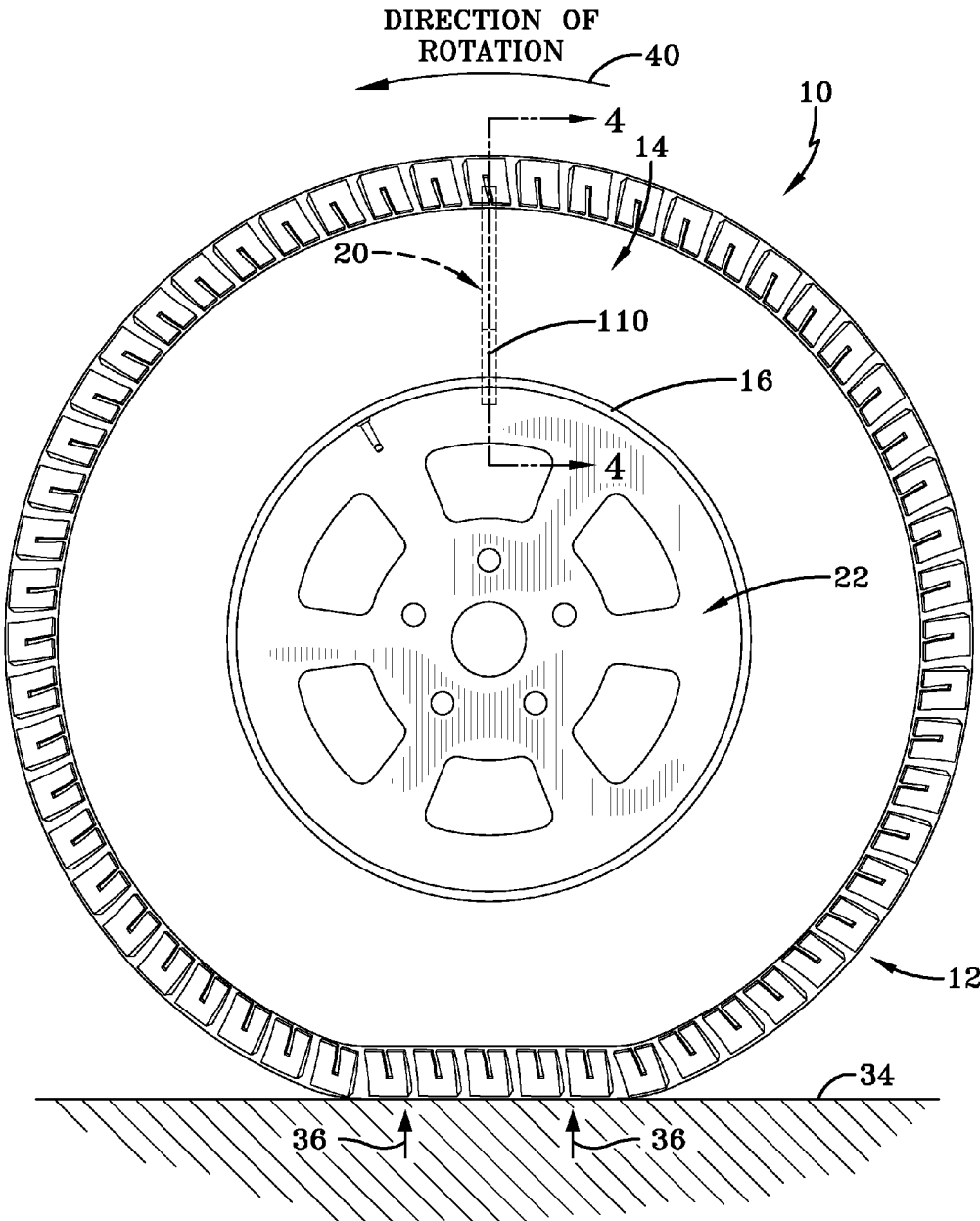
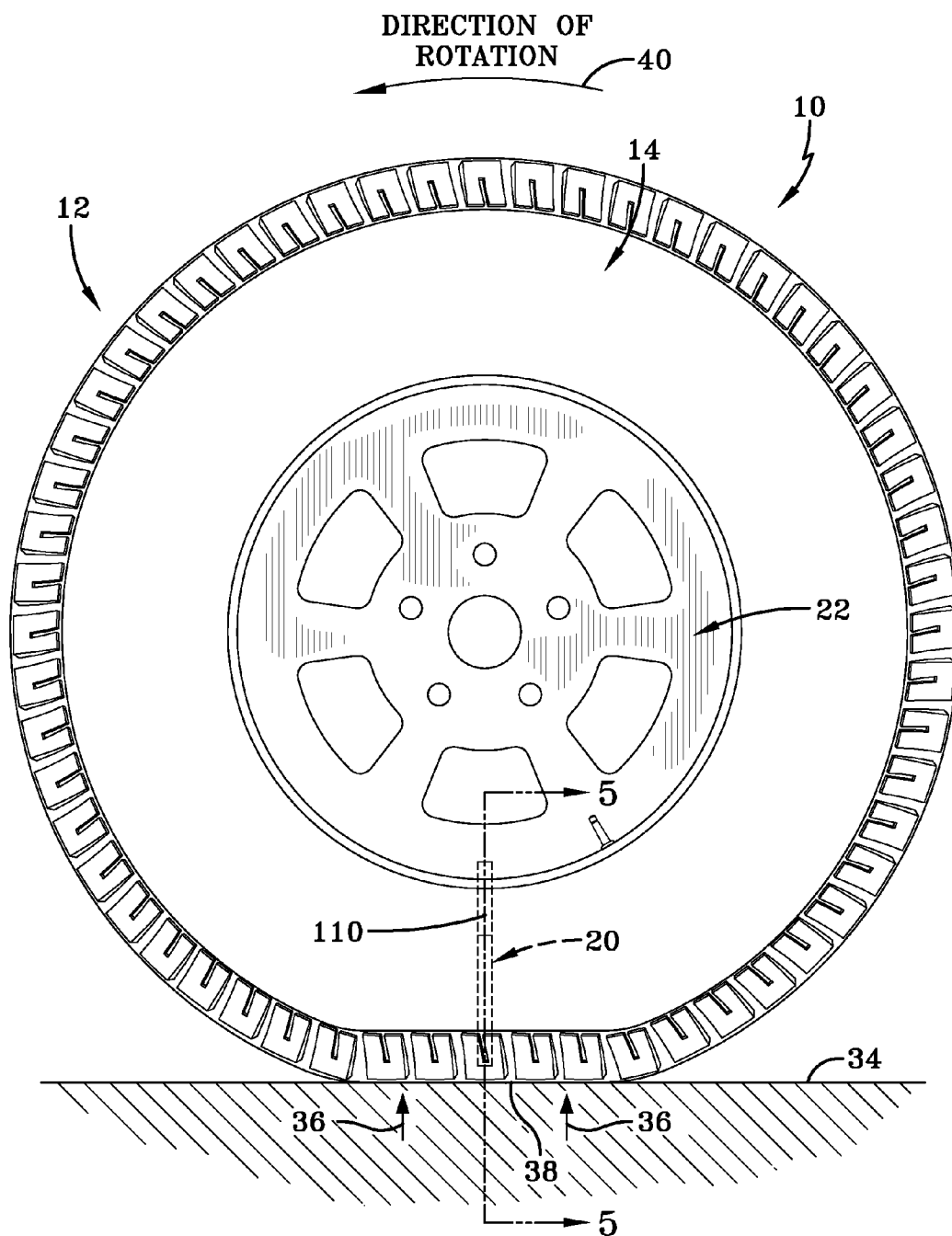

FIG-3A



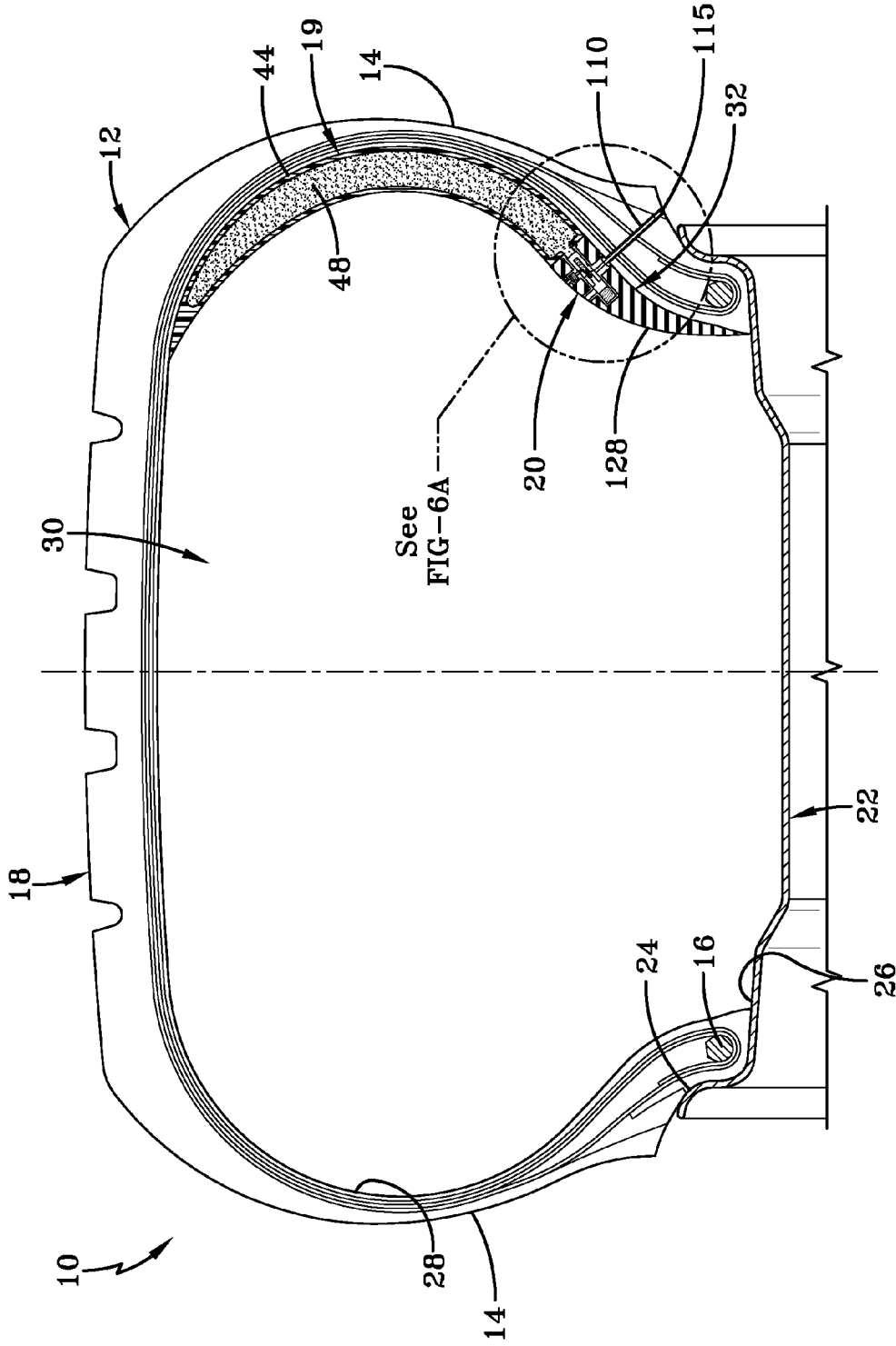

FIG-4

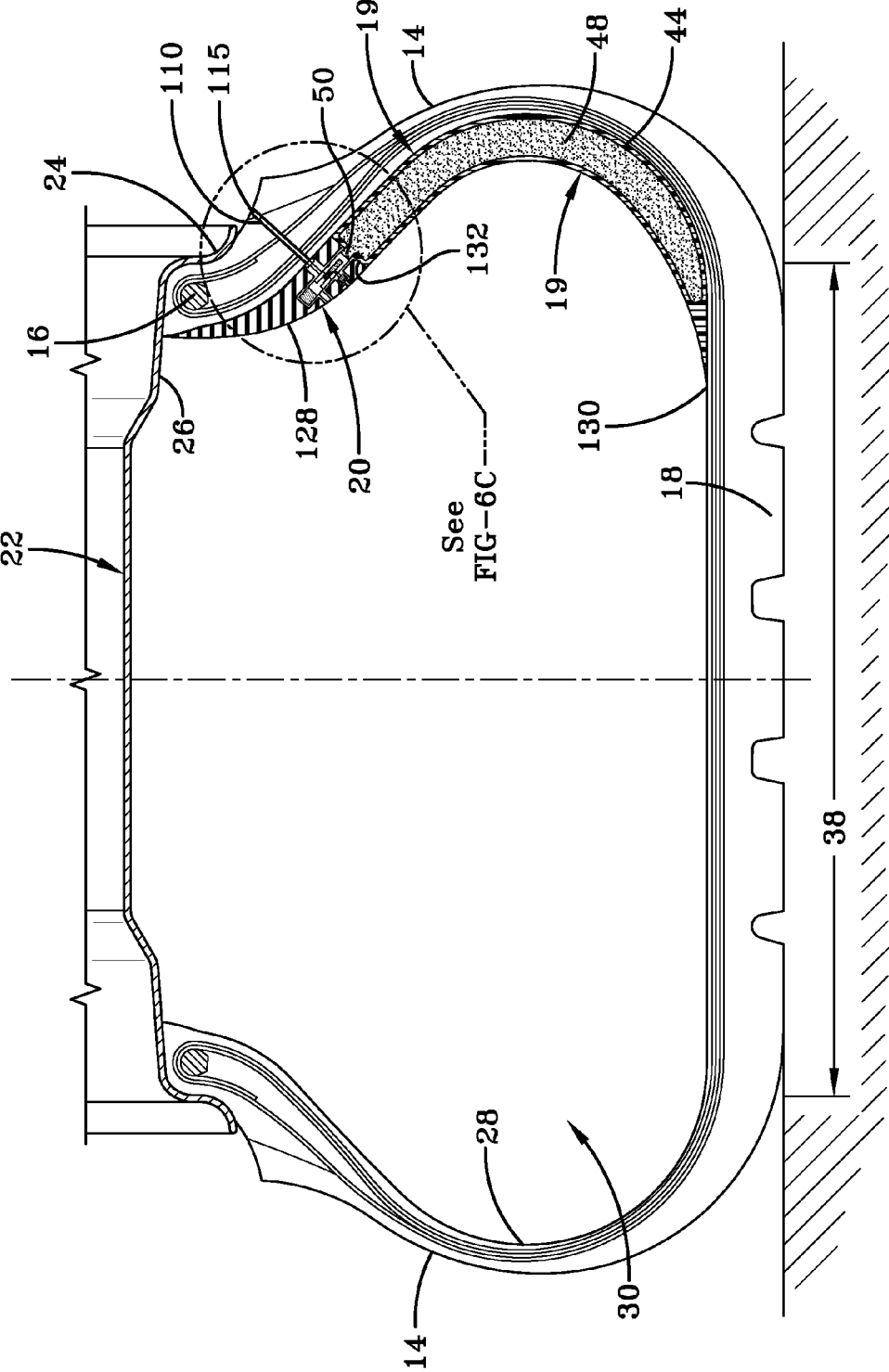

FIG-5

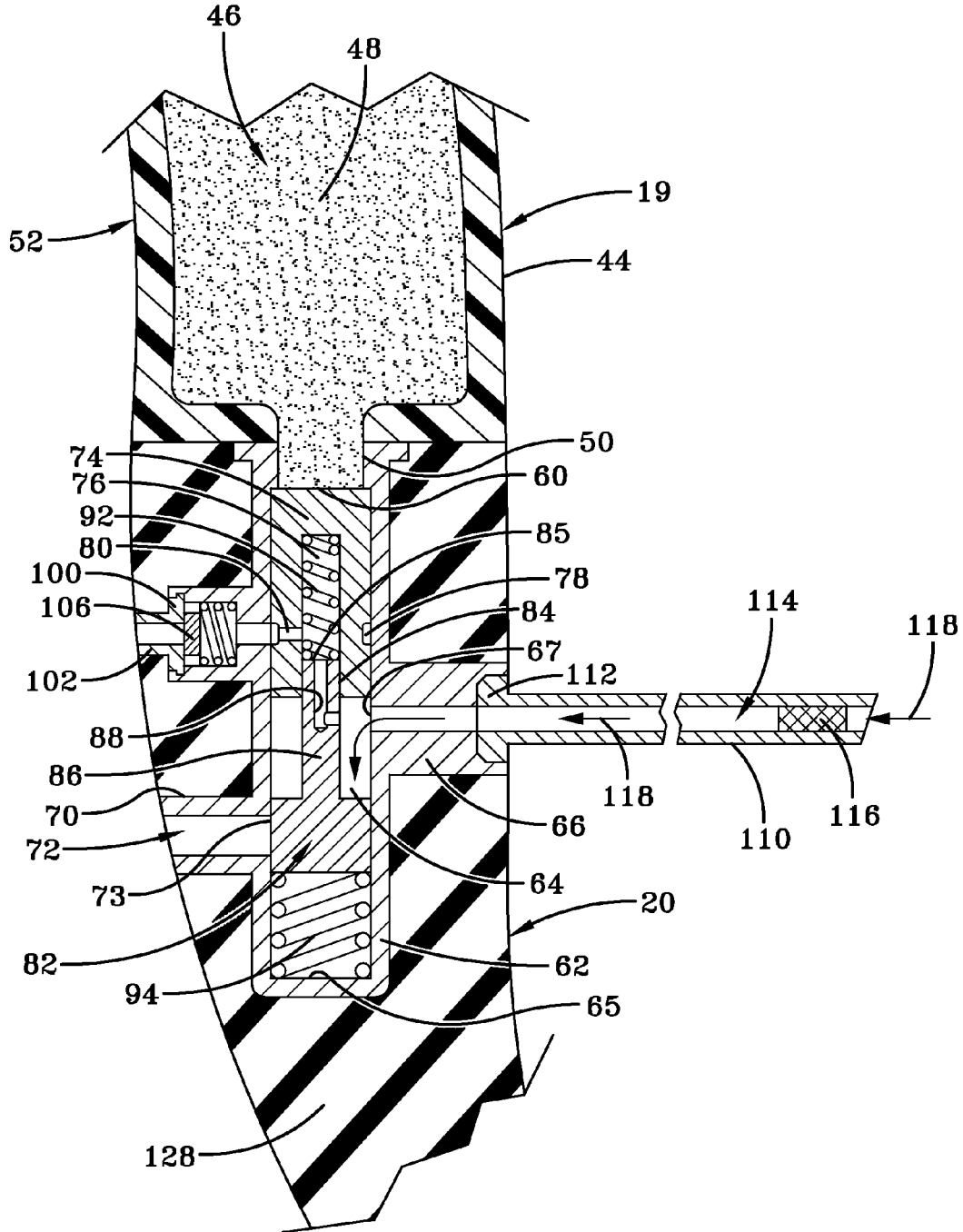

FIG-6A

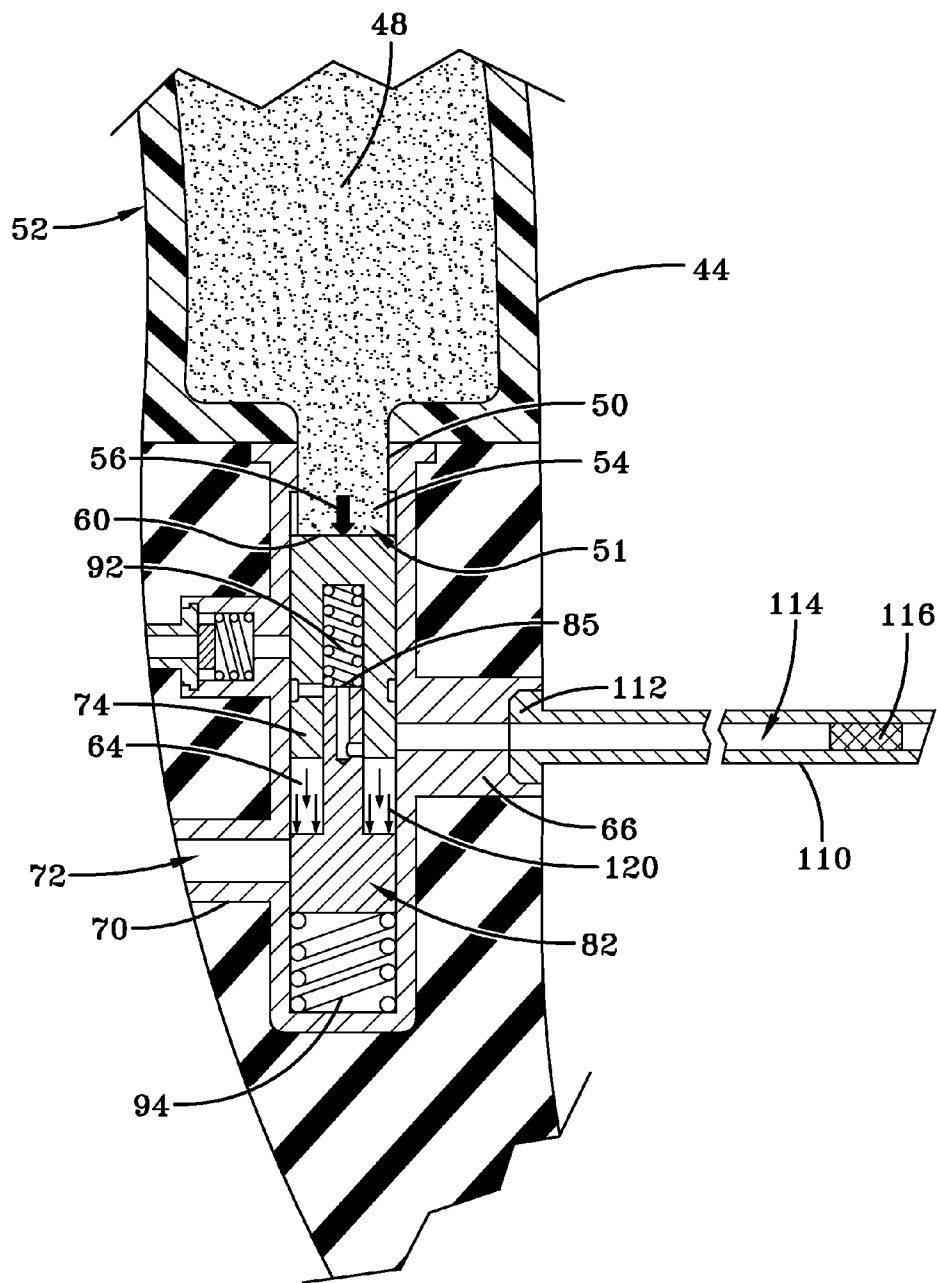

FIG-6B

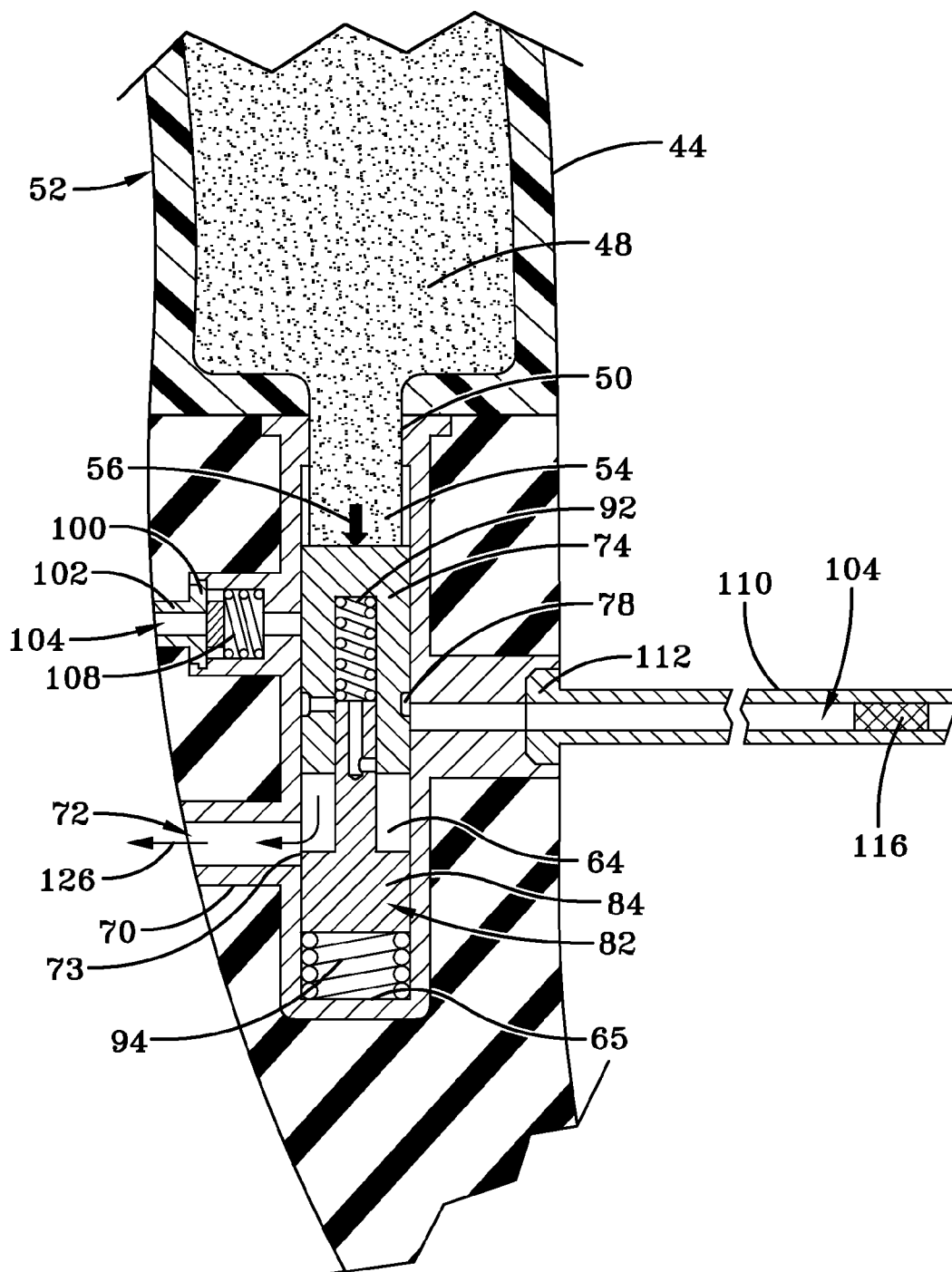

FIG-6C

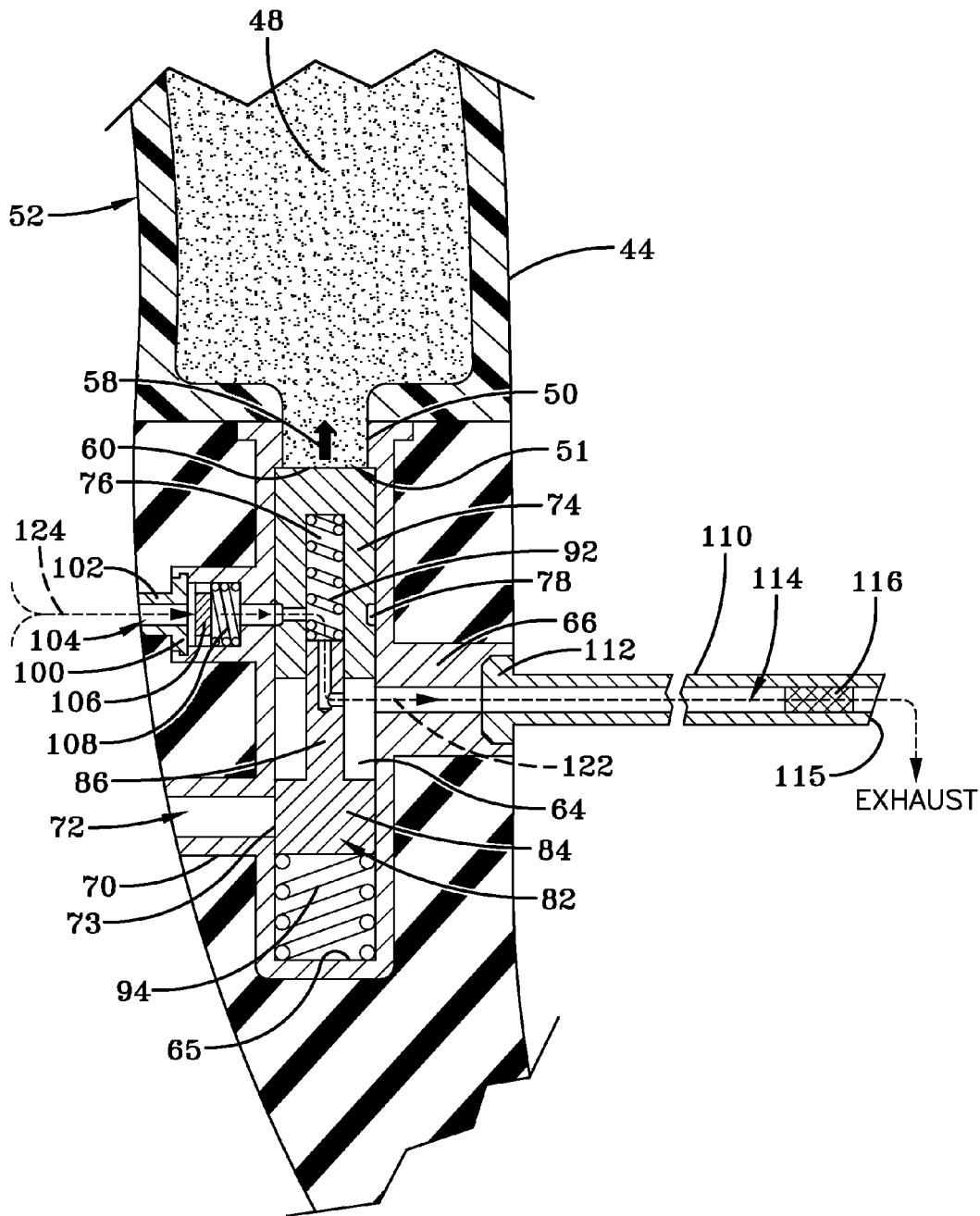

FIG-6D

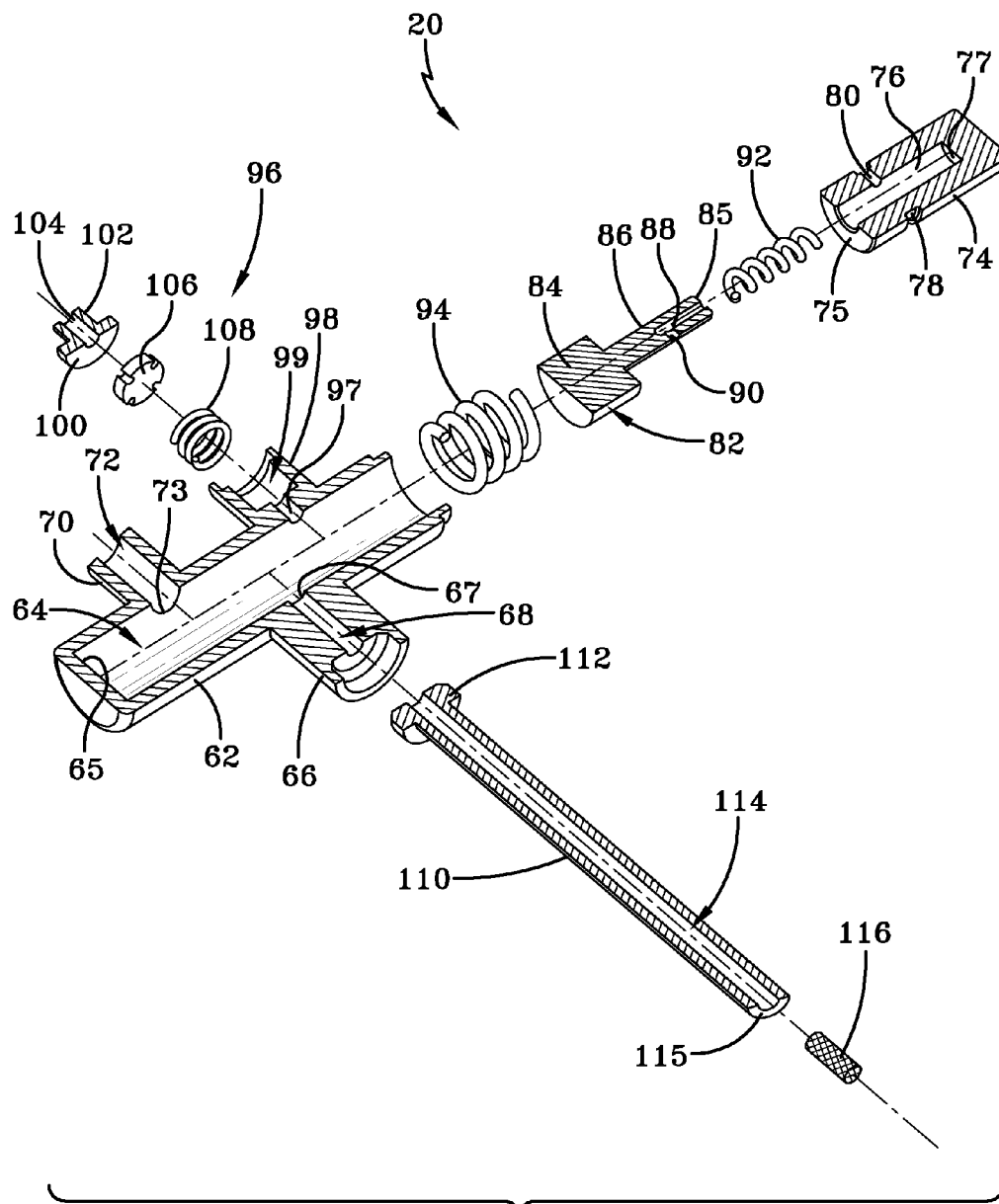

FIG-7

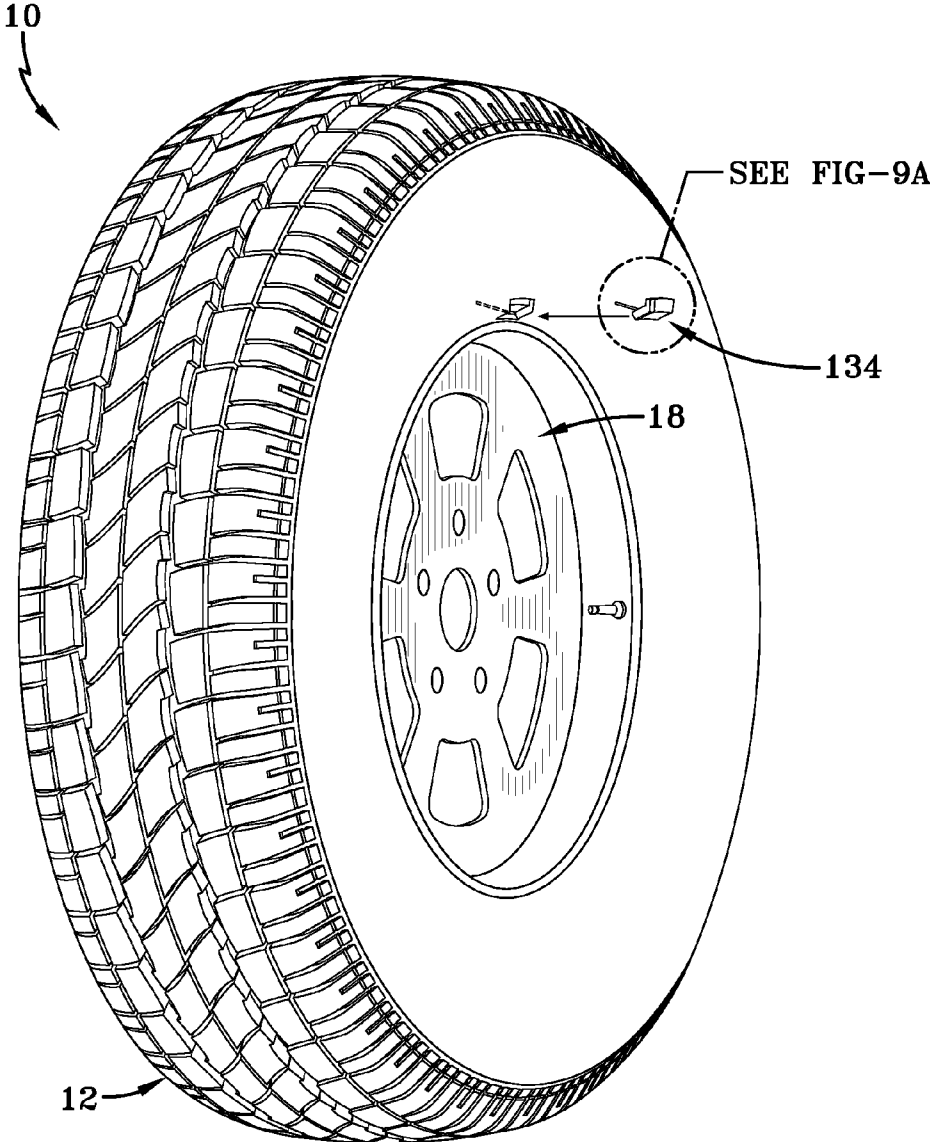

FIG-8

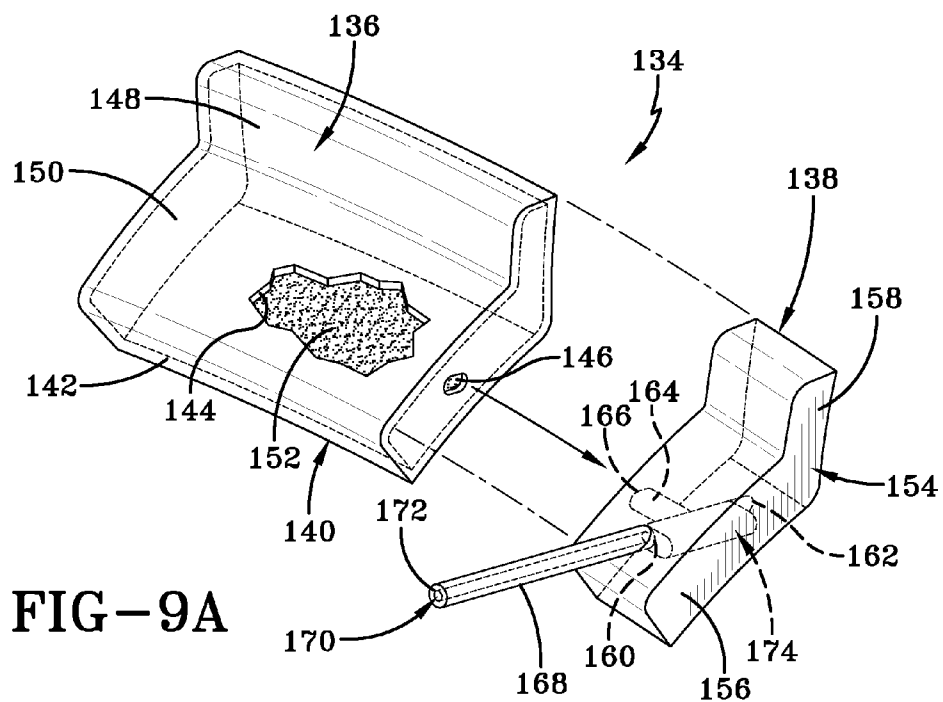

FIG-9A

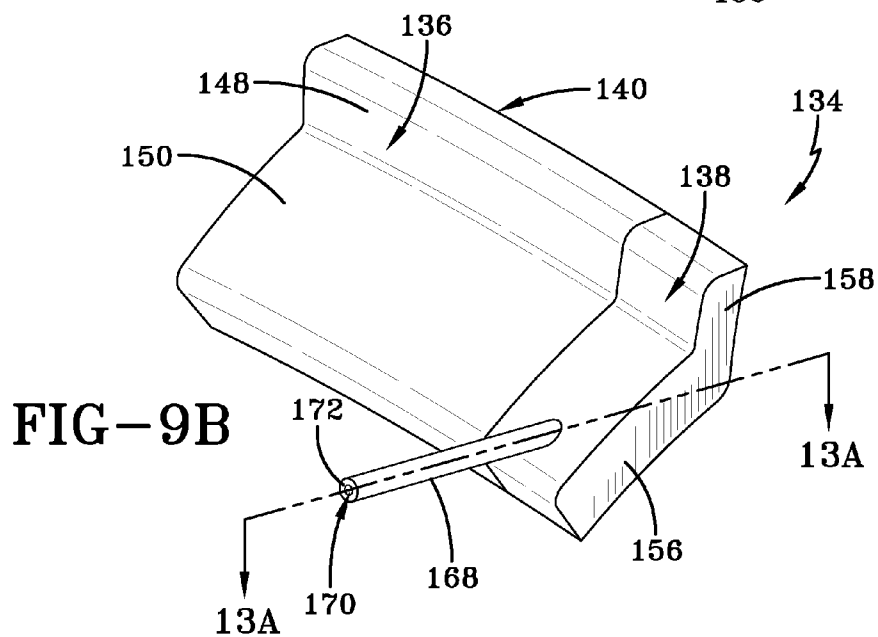

FIG-9B

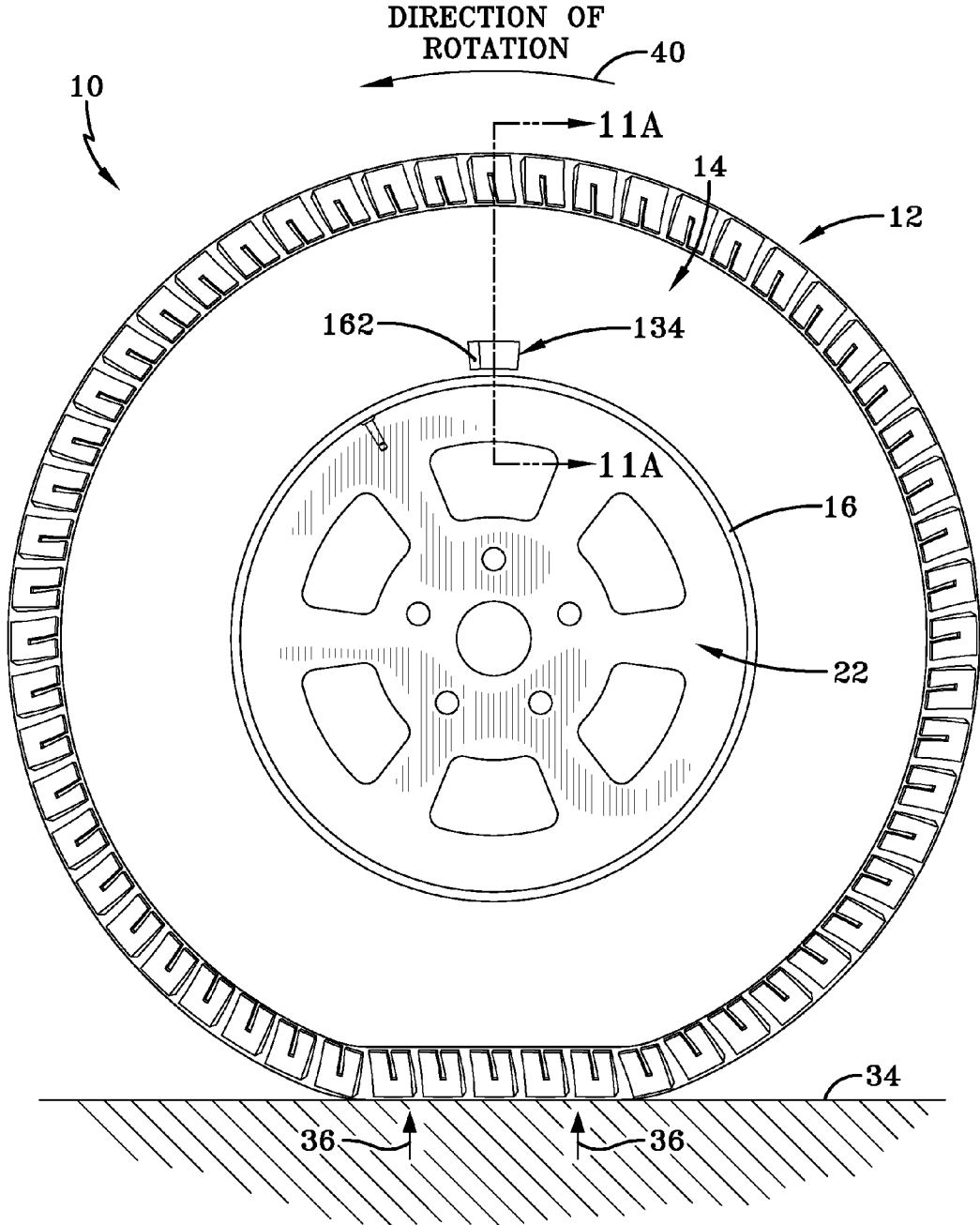

FIG-10A

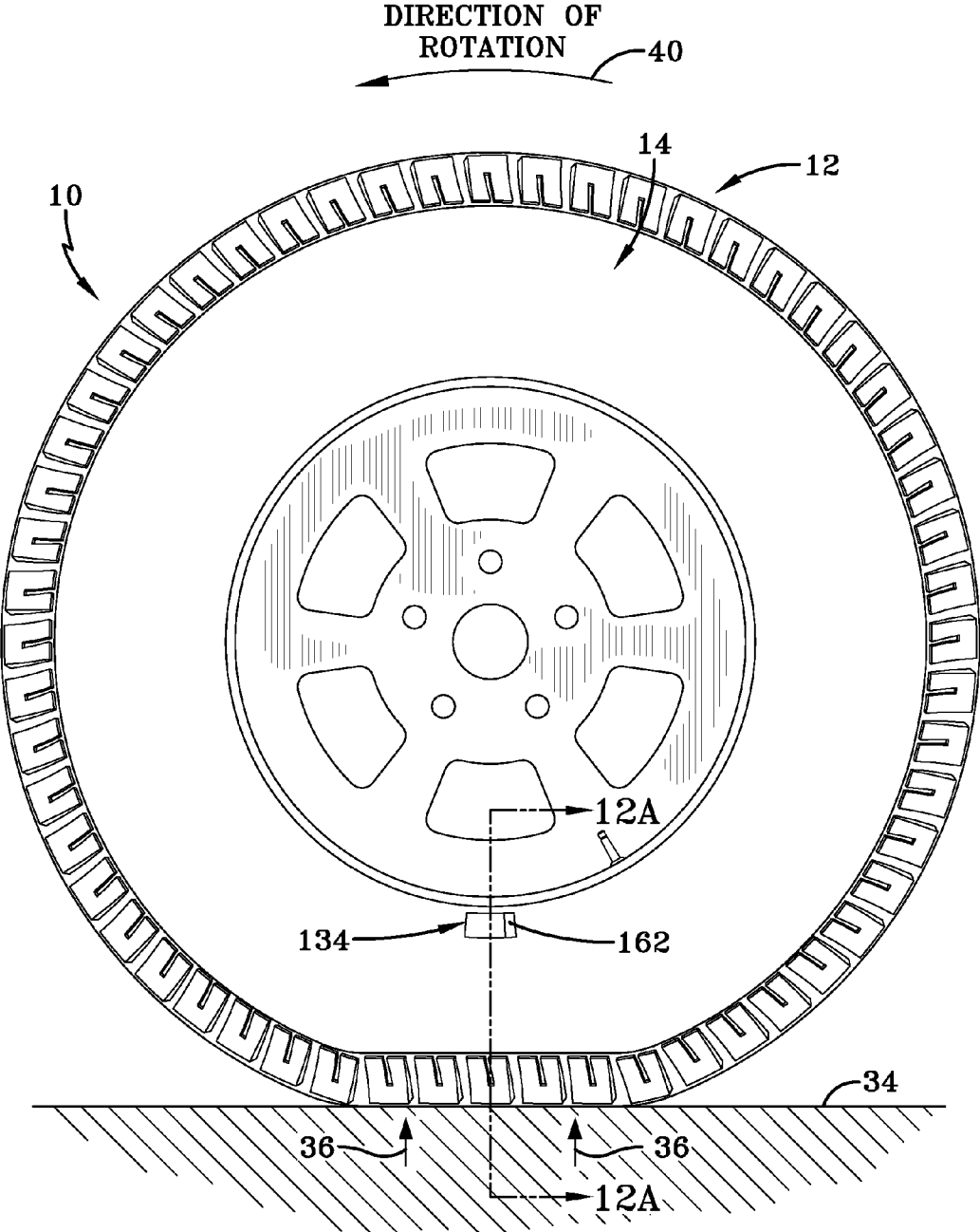

FIG-10B

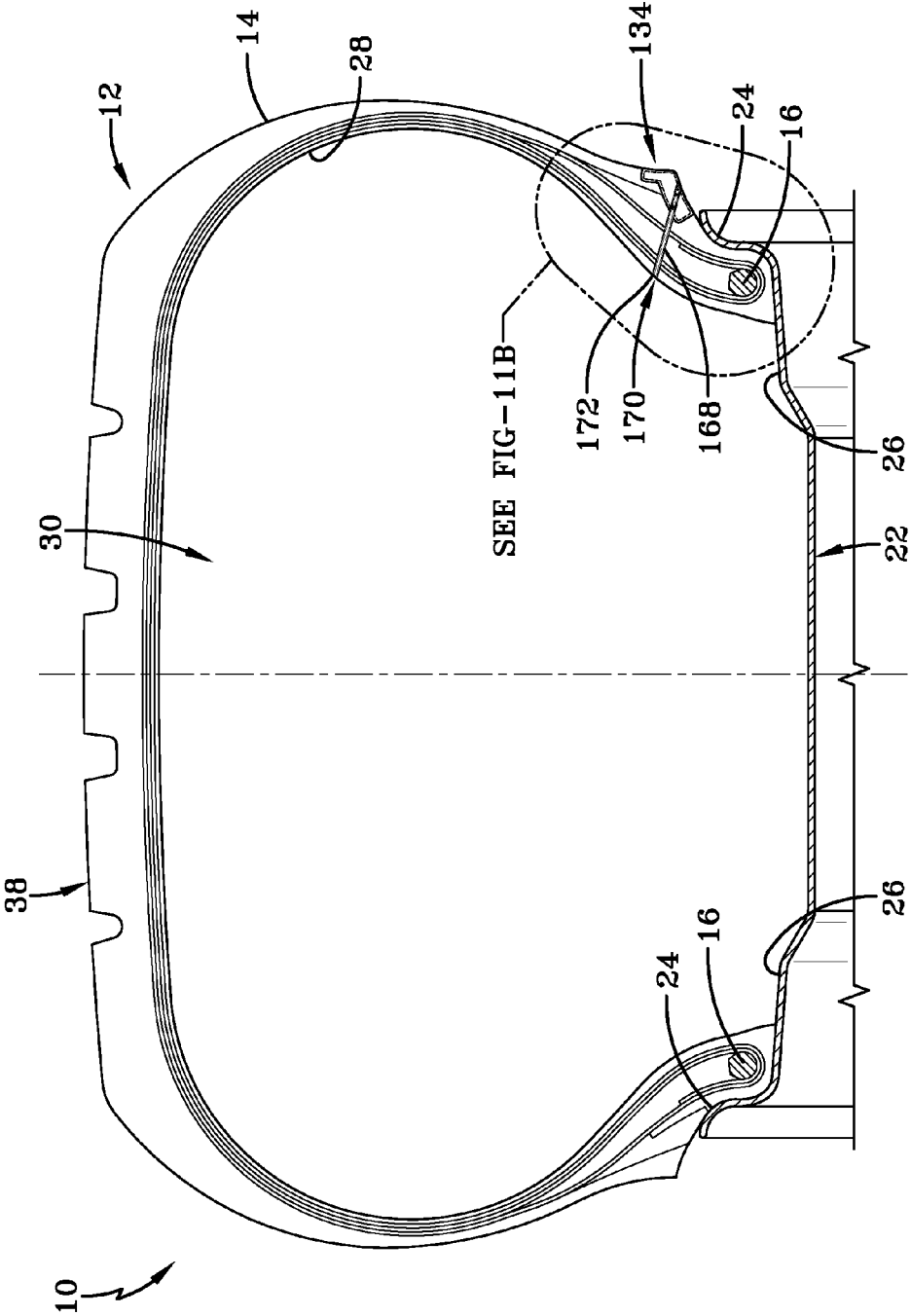

FIG-11A

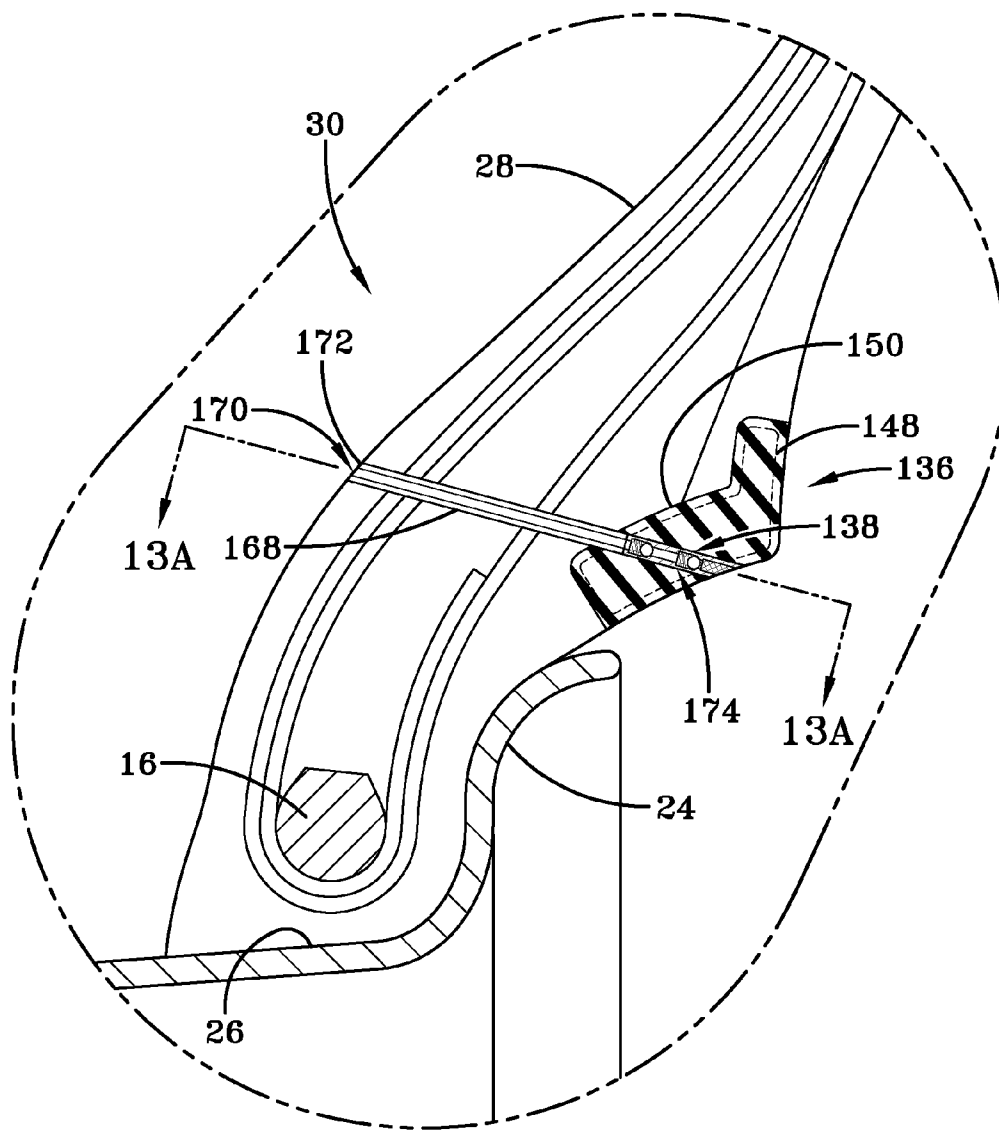

FIG-11B

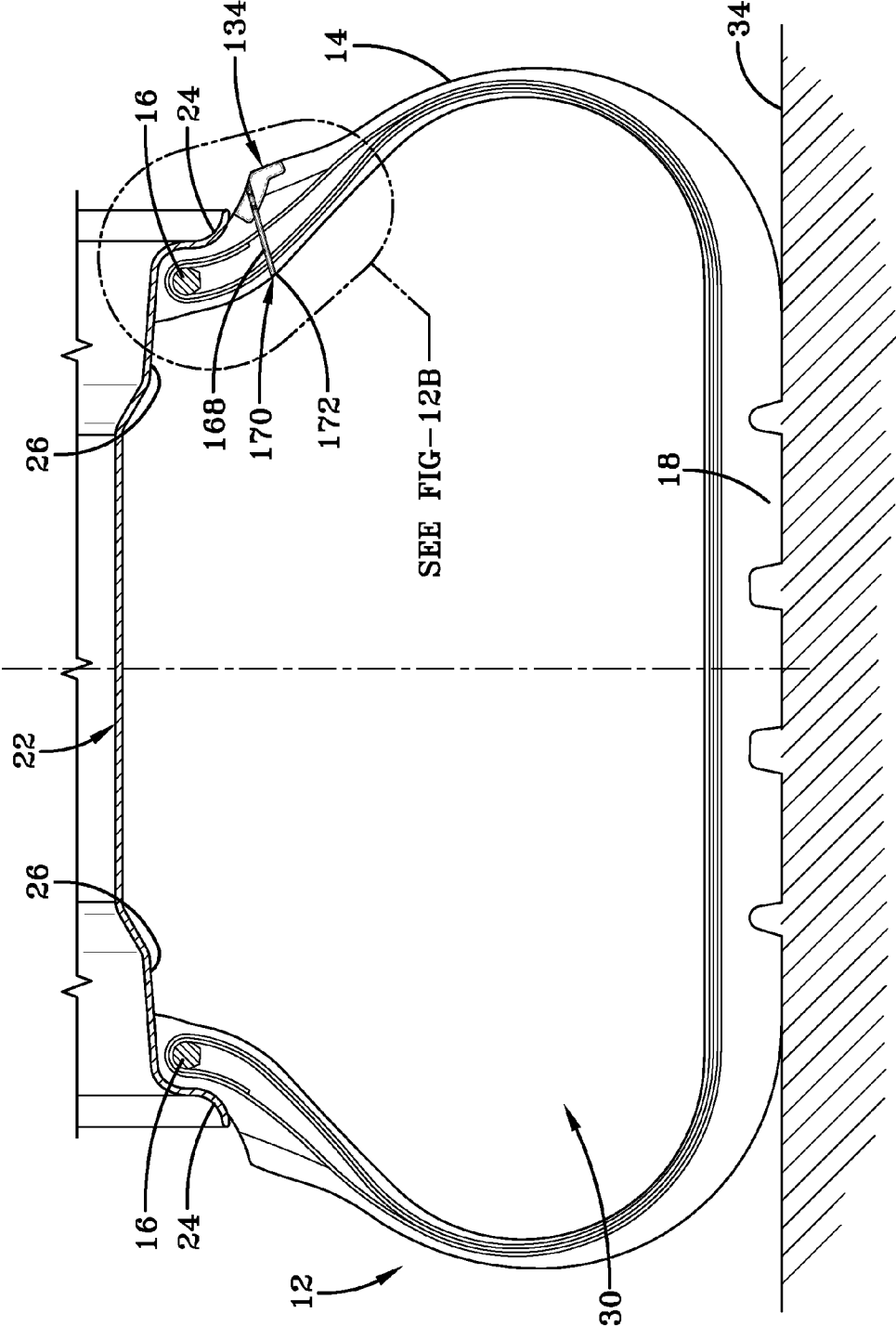

FIG-12A

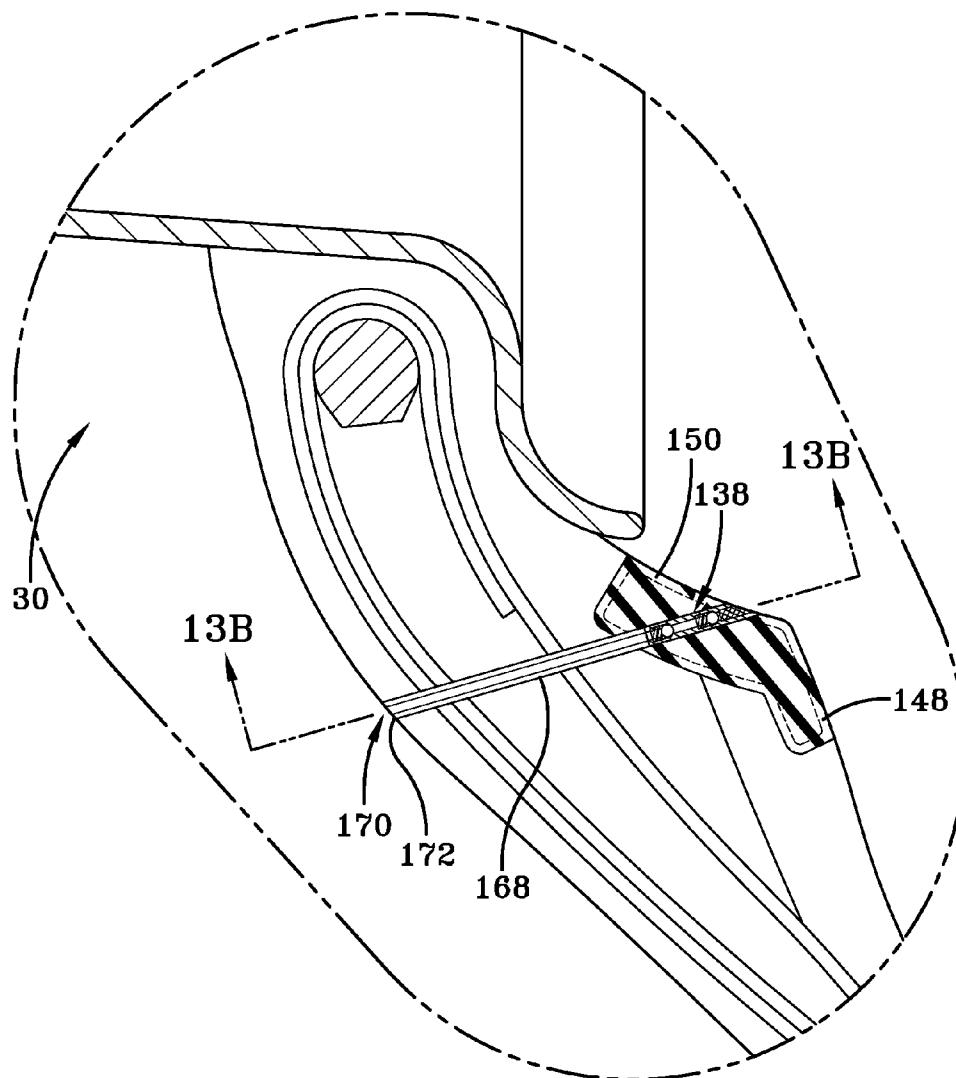

FIG-12B

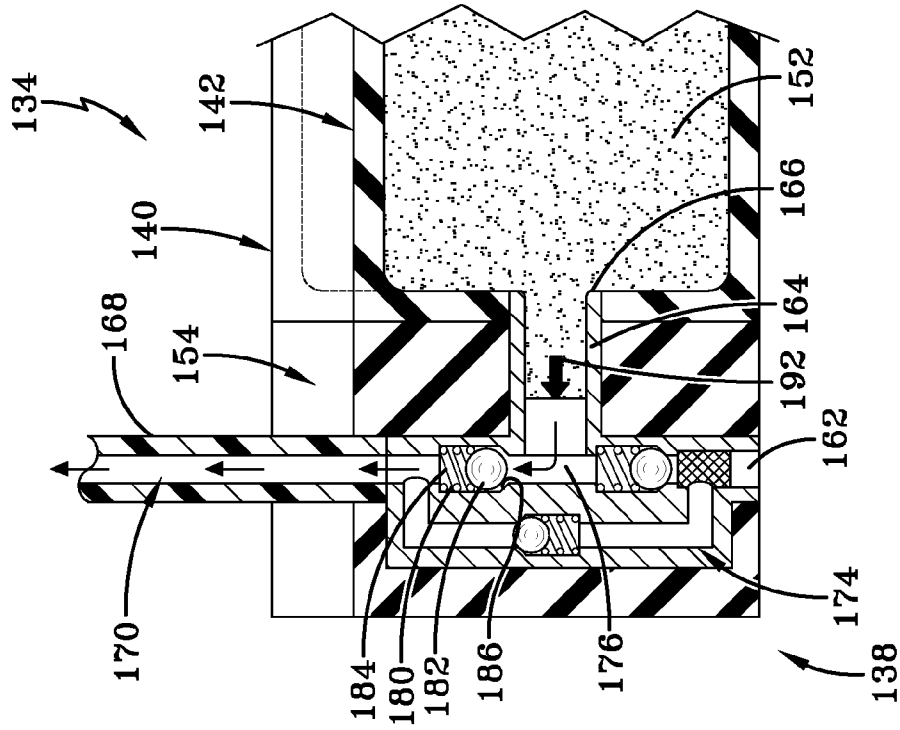

FIG-13B

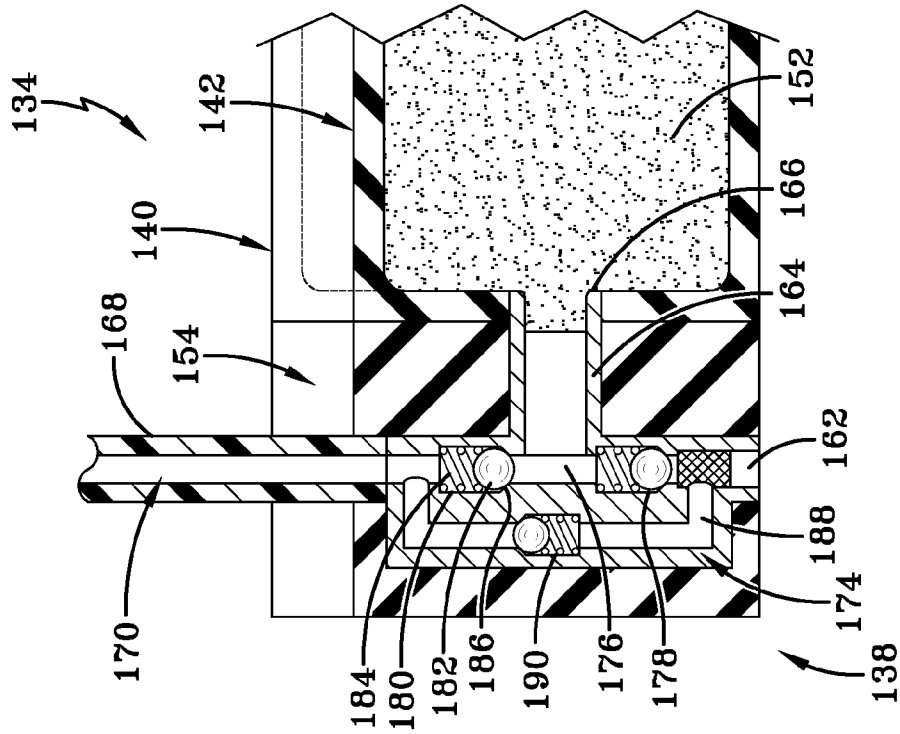

FIG-13A

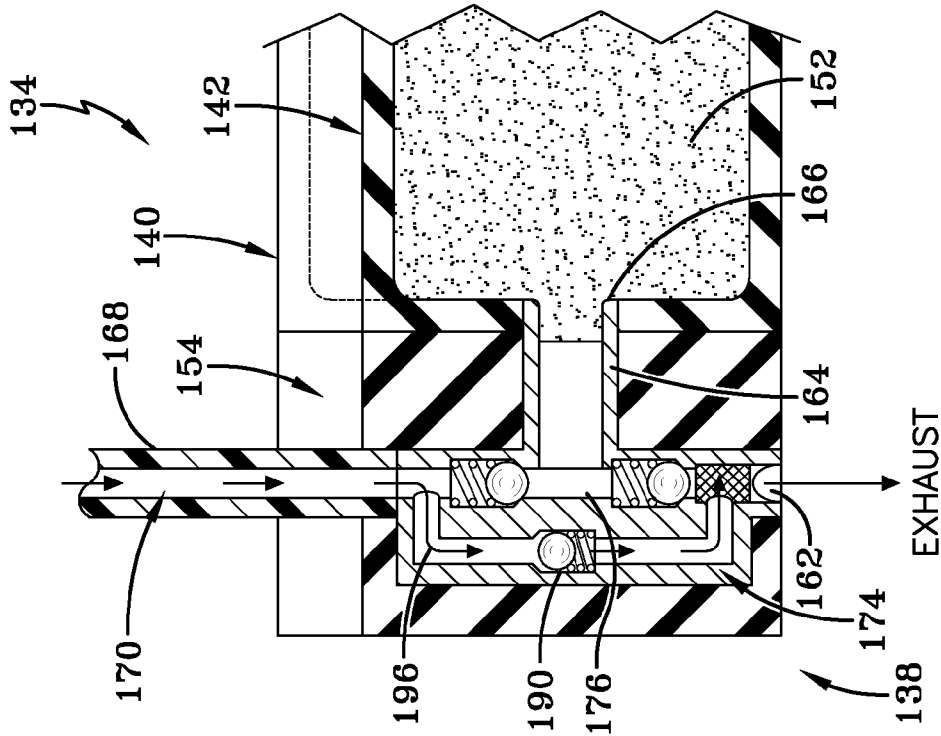

FIG-13D

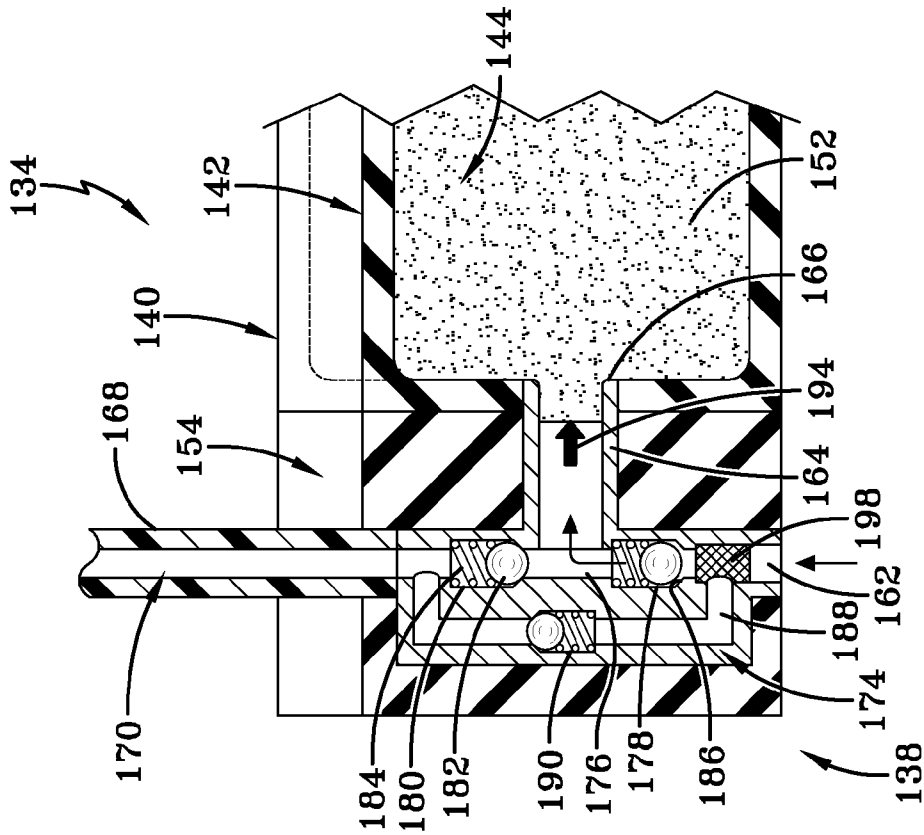
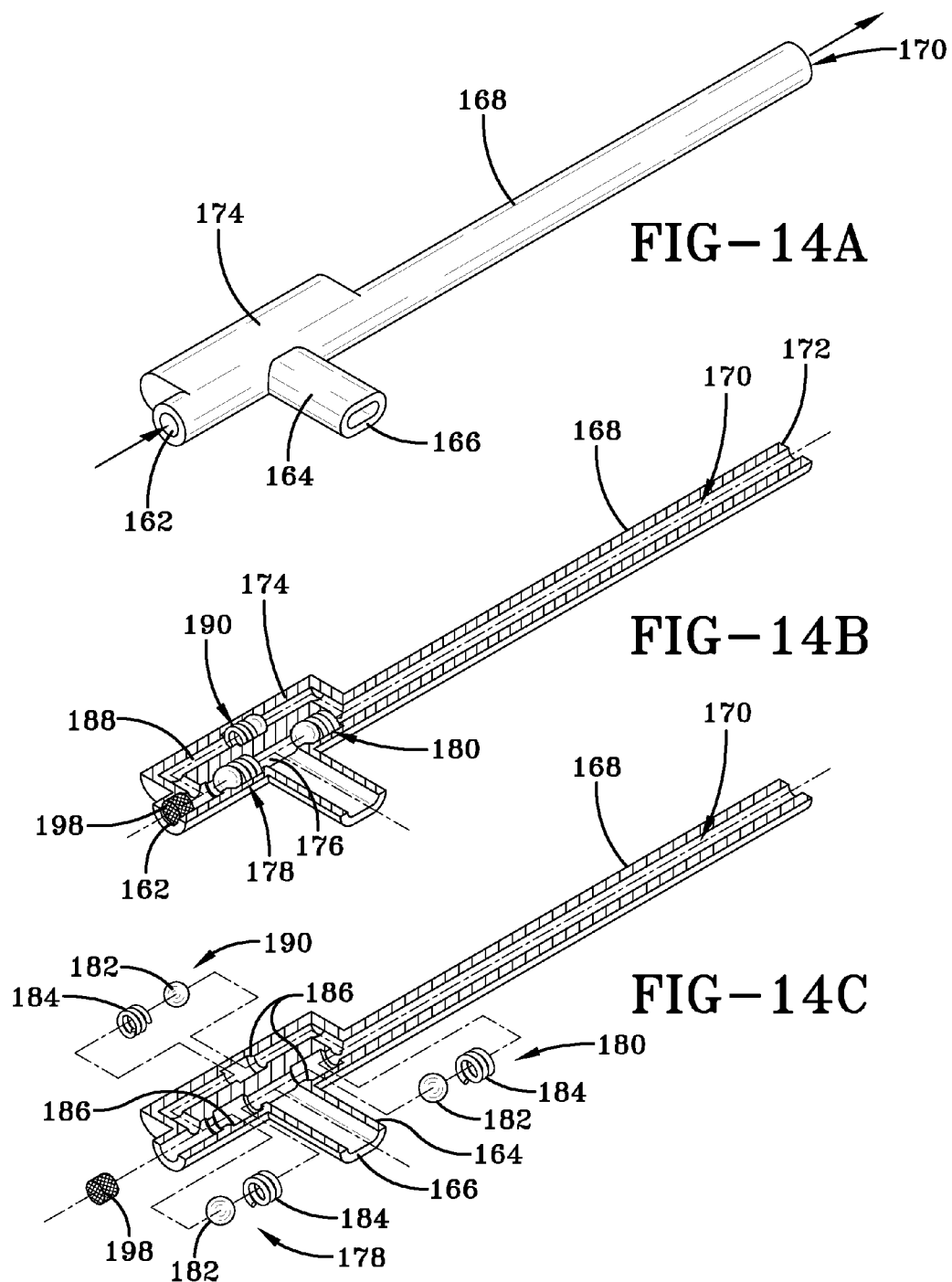

FIG-13C



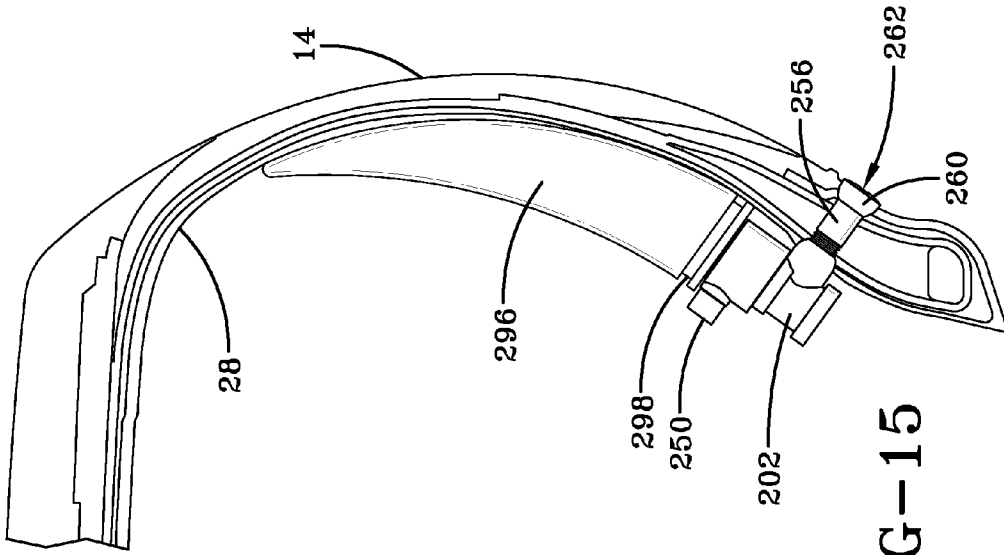

FIG-15

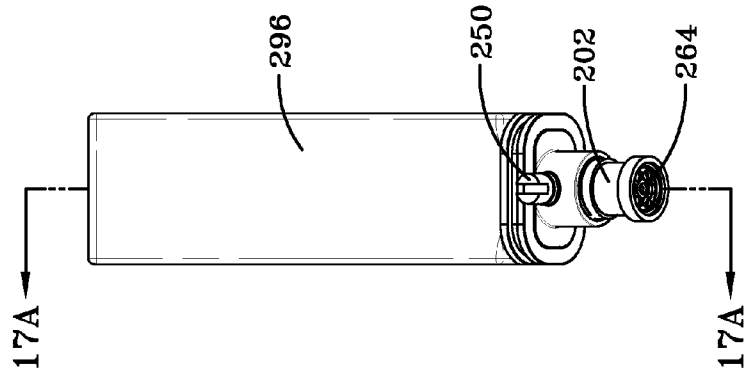

FIG-16

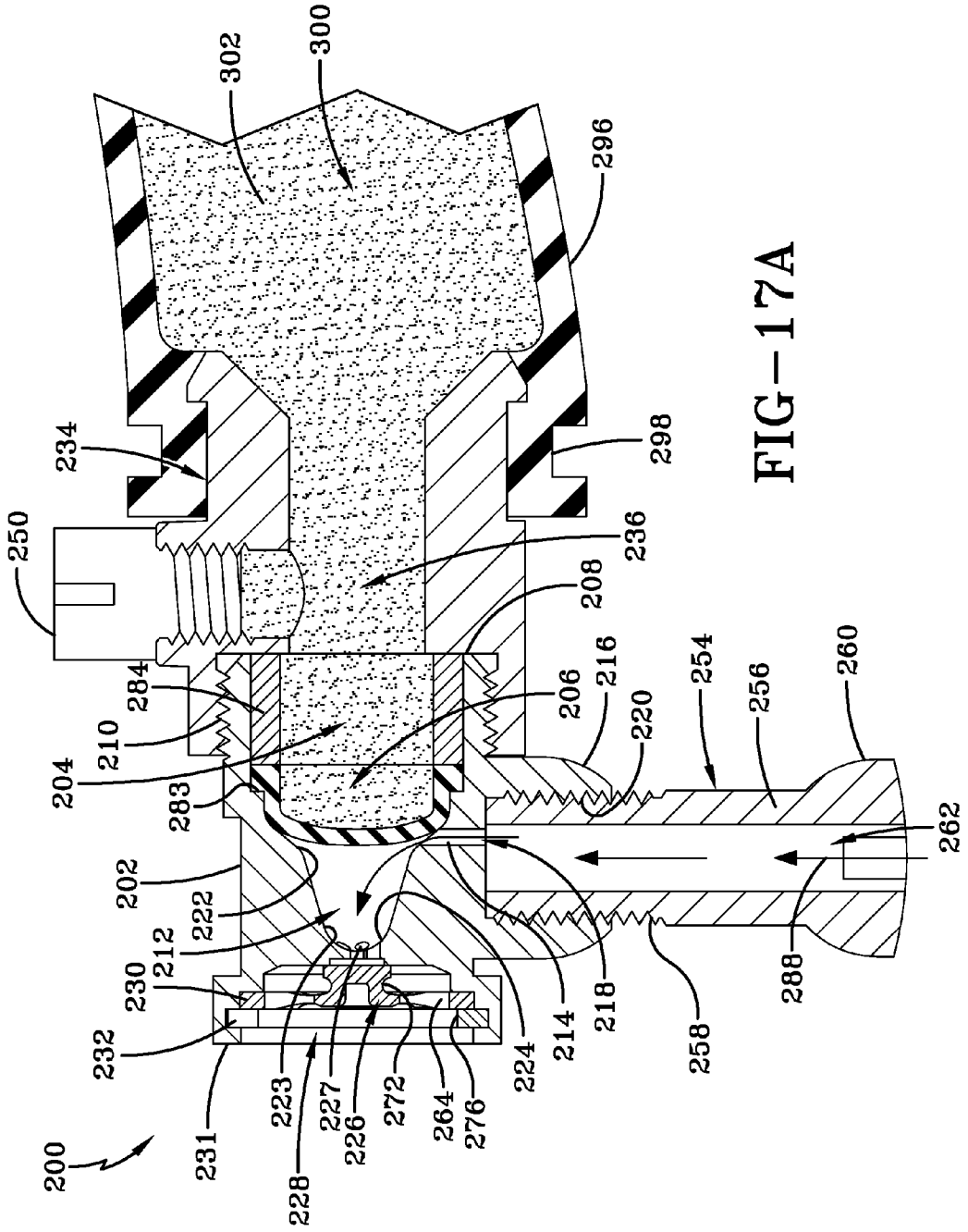
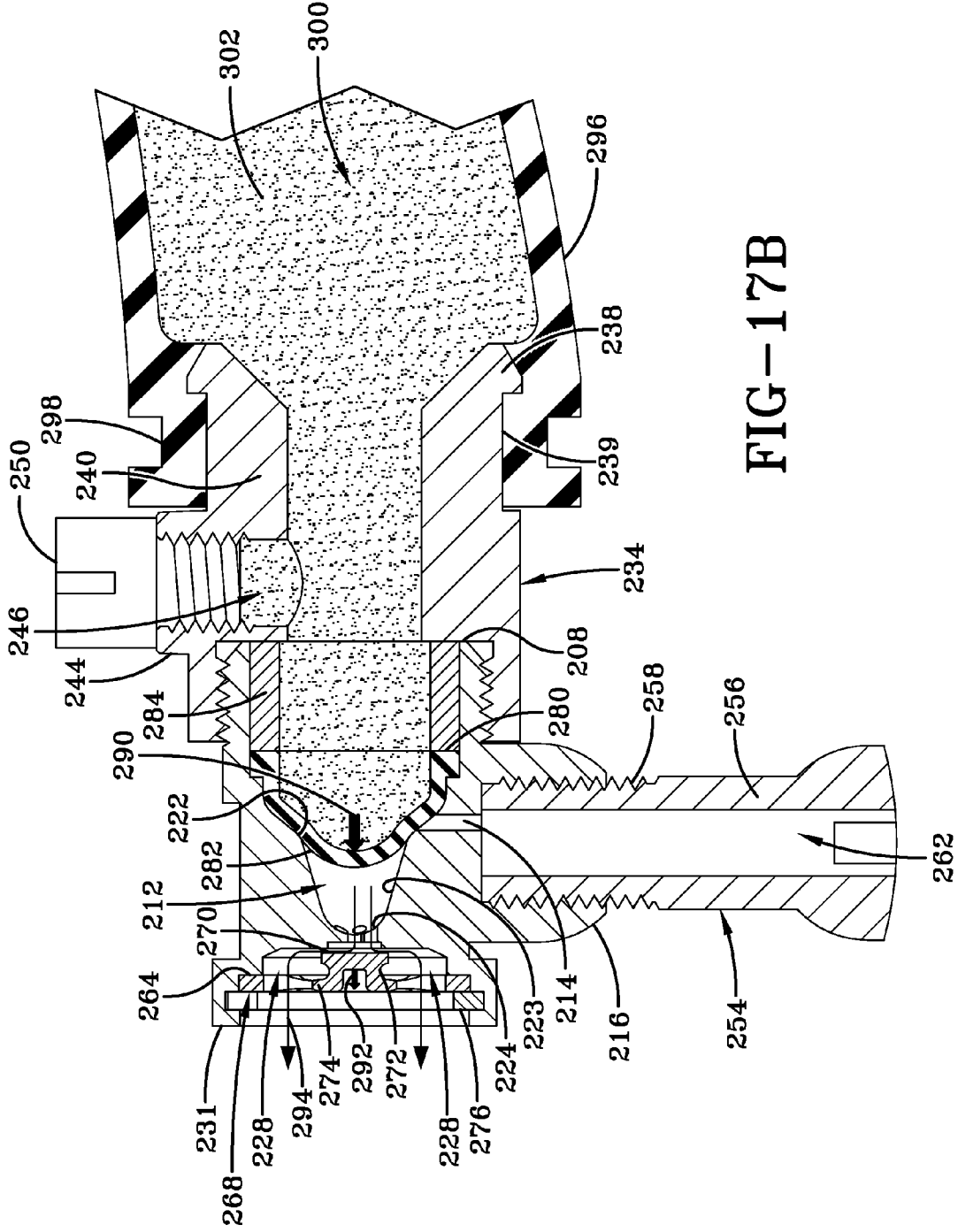

FIG-17A



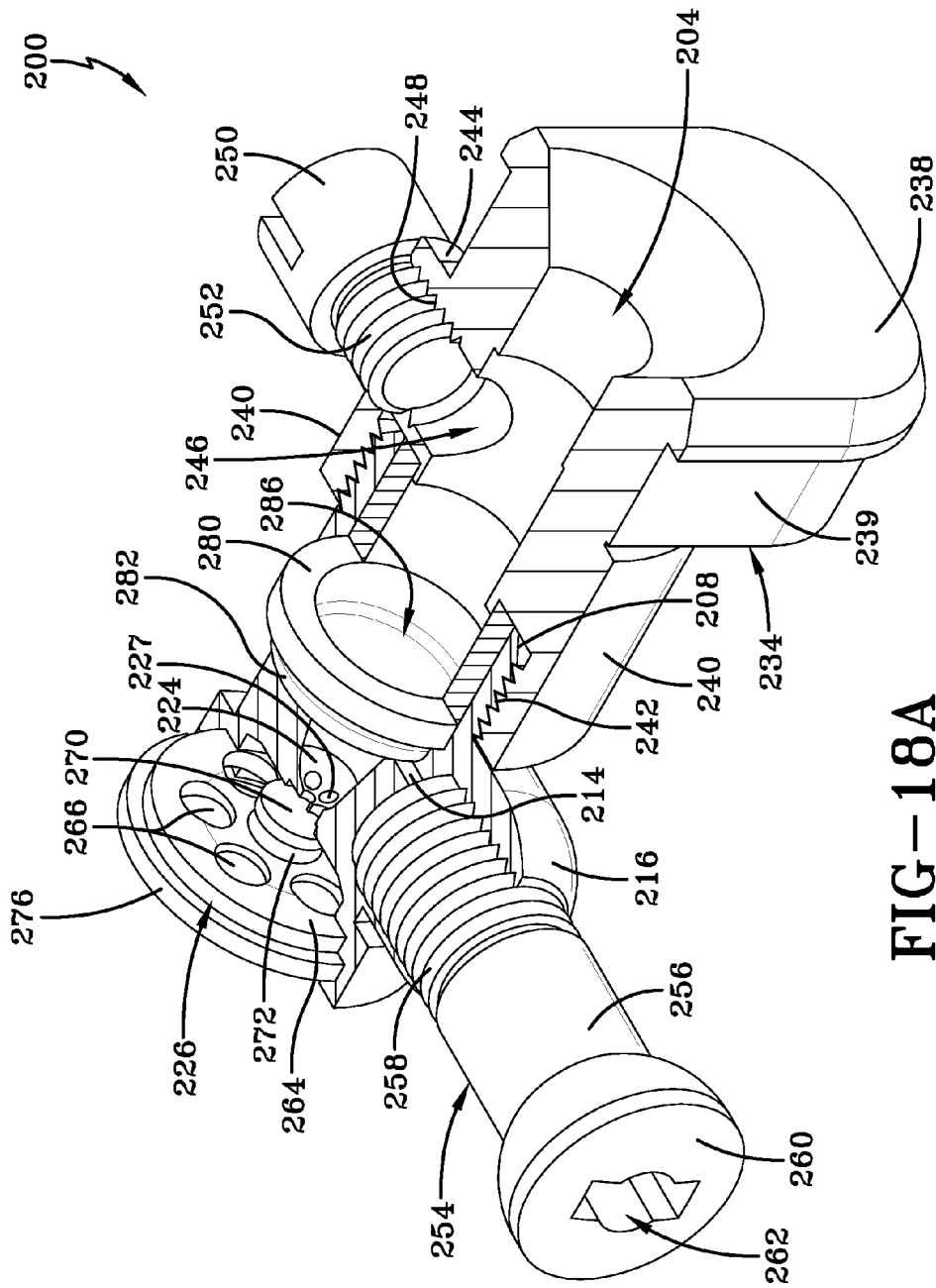

FIG-18A

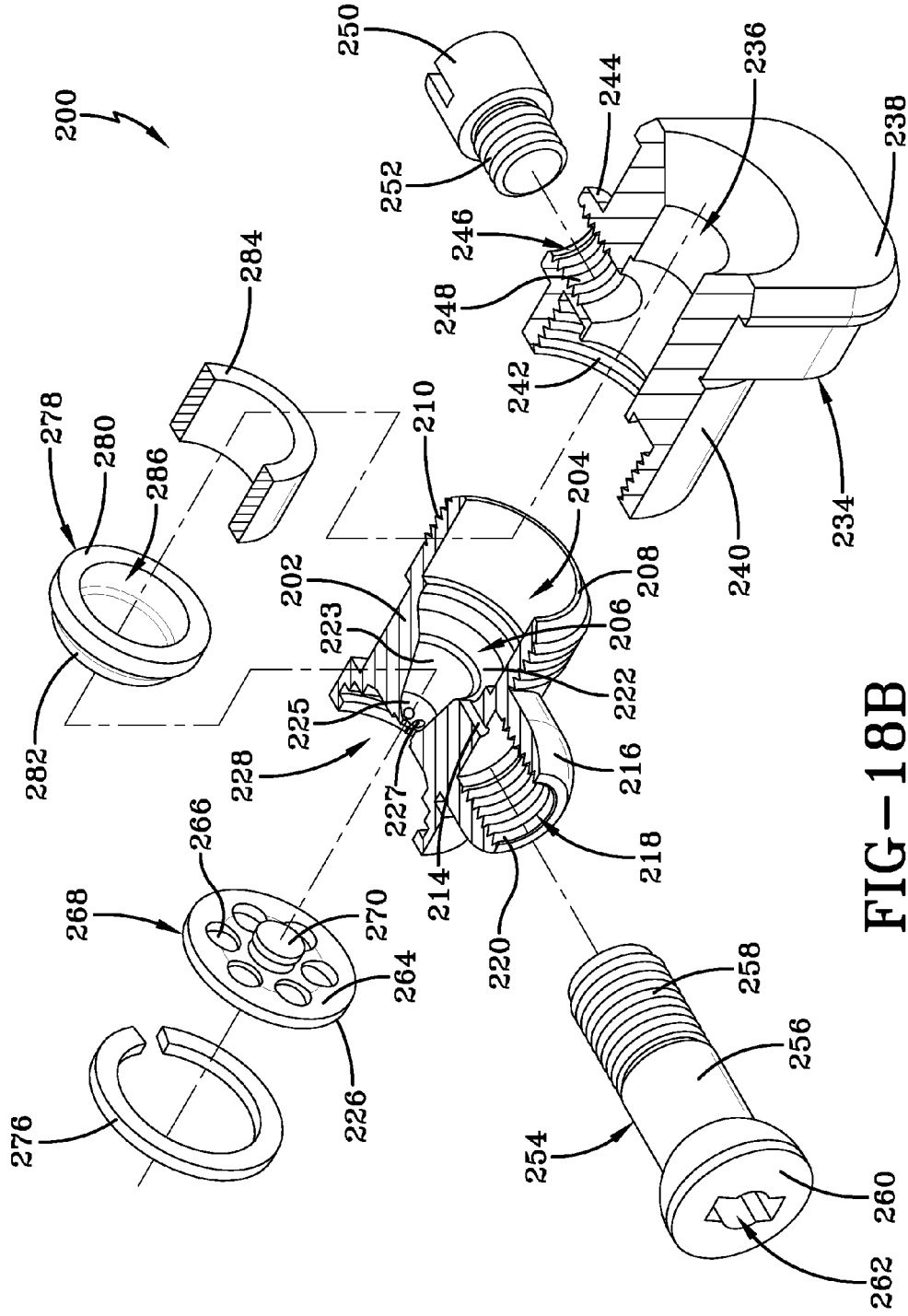

FIG-18B

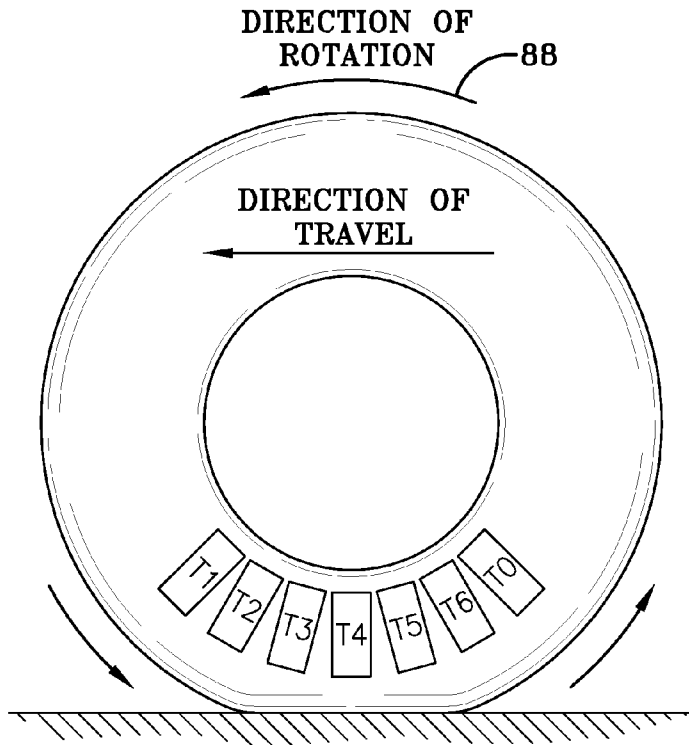

FIG-19A

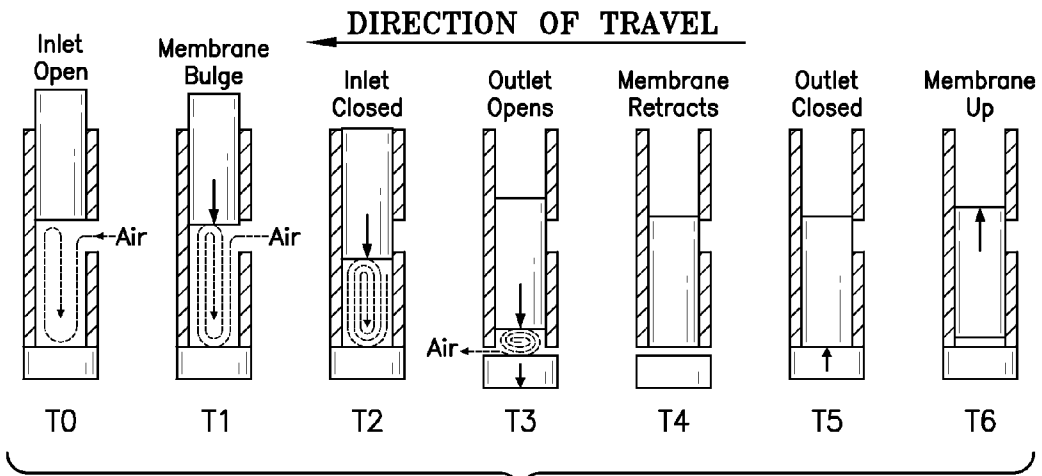

FIG-19B

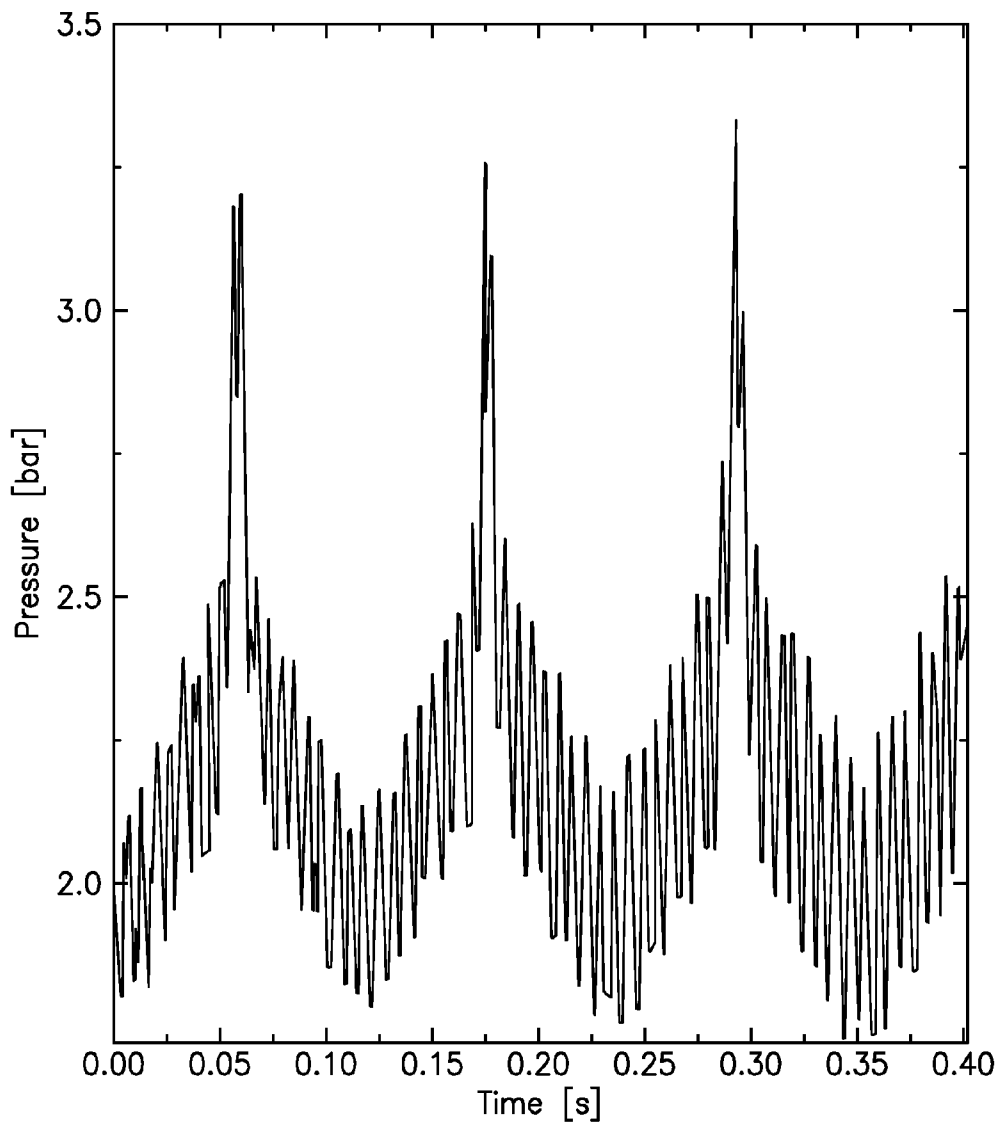

FIG-20

**HYDRAULIC MEMBRANE PUMP ASSEMBLY
FOR AIR MAINTENANCE TIRE**

FIELD OF THE INVENTION

[0001] The invention relates generally to air maintenance tires and, more specifically, to an air maintenance tire having an integrated air pumping system.

BACKGROUND OF THE INVENTION

[0002] Normal air diffusion reduces tire pressure over time. The natural state of tires is under inflated. Accordingly, drivers must repeatedly act to maintain tire pressures or they will see reduced fuel economy, tire life and reduced vehicle braking and handling performance. Tire Pressure Monitoring Systems (TPMS) have been proposed to warn drivers when tire pressure is significantly low. Such systems, however, remain dependant upon the driver taking remedial action when warned to re-inflate a tire to recommended pressure. It is a desirable, therefore, to incorporate an air maintenance feature within a tire that will auto-maintain air pressure within the tire.

SUMMARY OF THE INVENTION

[0003] In one aspect of the invention, an air-maintenance tire system includes a compression actuator mounted to the tire carcass configured for operative actuation by tire deformation during a tire revolution, a pump assembly affixed to the tire carcass and including a compressor body affixed to the compression actuator and having an internal air chamber, the air chamber having an inlet opening for admitting air into the internal air chamber and an outlet opening for conducting air from the internal air chamber to the tire cavity. The air compressor body further includes a deformable membrane member and an outlet valve member located within and at opposite respective ends of the internal air chamber, the membrane valve member deforming under fluid pressure from the compression actuator to compress a volume of air within the air chamber. According to a further aspect, the membrane member and the outlet valve member move within the internal air chamber responsive to actuation by the compression actuator between respective open and closed positions, whereby cyclically opening and closing the inlet and the outlet openings during an air compression cycle.

[0004] In another aspect, the membrane valve member in the open position relative to the inlet opening permits air flow from the inlet opening into the air chamber and in the closed position relative to the inlet opening obstructs air flow from the inlet opening into the air chamber, and wherein the piston valve member during movement between the open and closed positions operatively compresses a volume of air within the air chamber.

[0005] According to a further aspect, the outlet valve member in the closed position relative to the outlet opening is operative to move to the open position responsive to air pressure within the air chamber reaching a preset threshold wherein permitting air flow from the air chamber into the outlet opening.

[0006] The air-maintenance tire system, in accordance with an additional aspect, in which the compression actuator is a hollow containment body formed from a resilient deformable material composition and containing a quantity of a non-compressible medium. The containment body is affixed to a relatively high flex-deformation region of the tire carcass and

reciprocally transforms between a deformed state and a non-deformed state responsive to deformation and recovery of the tire high flex-deformation region in a rolling tire. The actuator containment body in the deformed state displaces a pressurized displaced quantity of the non-compressible medium which generates a compression force against a piston valve member surface to move the piston valve between the open and closed positions within the air chamber.

DEFINITIONS

[0007] “Aspect ratio” of the tire means the ratio of its section height (SH) to its section width (SW) multiplied by 100 percent for expression as a percentage.

[0008] “Asymmetric tread” means a tread that has a tread pattern not symmetrical about the center plane or equatorial plane EP of the tire.

[0009] “Axial” and “axially” means lines or directions that are parallel to the axis of rotation of the tire.

[0010] “Chafer” is a narrow strip of material placed around the outside of a tire bead to protect the cord plies from wearing and cutting against the rim and distribute the flexing above the rim.

[0011] “Circumferential” means lines or directions extending along the perimeter of the surface of the annular tread perpendicular to the axial direction.

[0012] “Equatorial Centerplane (CP)” means the plane perpendicular to the tire’s axis of rotation and passing through the center of the tread.

[0013] “Footprint” means the contact patch or area of contact of the tire tread with a flat surface at zero speed and under normal load and pressure.

[0014] “Groove” means an elongated void area in a tire wall that may extend circumferentially or laterally about the tire wall. The “groove width” is equal to its average width over its length. A groove is sized to accommodate an air tube as described.

[0015] “Inboard side” means the side of the tire nearest the vehicle when the tire is mounted on a wheel and the wheel is mounted on the vehicle.

[0016] “Lateral” means an axial direction.

[0017] “Lateral edges” means a line tangent to the axially outermost tread contact patch or footprint as measured under normal load and tire inflation, the lines being parallel to the equatorial centerplane.

[0018] “Net contact area” means the total area of ground contacting tread elements between the lateral edges around the entire circumference of the tread divided by the gross area of the entire tread between the lateral edges.

[0019] “Non-directional tread” means a tread that has no preferred direction of forward travel and is not required to be positioned on a vehicle in a specific wheel position or positions to ensure that the tread pattern is aligned with the preferred direction of travel. Conversely, a directional tread pattern has a preferred direction of travel requiring specific wheel positioning.

[0020] “Outboard side” means the side of the tire farthest away from the vehicle when the tire is mounted on a wheel and the wheel is mounted on the vehicle.

[0021] “Peristaltic” means operating by means of wave-like contractions that propel contained matter, such as air, along tubular pathways.

[0022] “Radial” and “radially” means directions radially toward or away from the axis of rotation of the tire.

[0023] “Rib” means a circumferentially extending strip of rubber on the tread which is defined by at least one circumferential groove and either a second such groove or a lateral edge, the strip being laterally undivided by full-depth grooves.

[0024] “Sipe” means small slots molded into the tread elements of the tire that subdivide the tread surface and improve traction, sipes are generally narrow in width and close in the tire's footprint as opposed to grooves that remain open in the tire's footprint.

[0025] “Tread element” or “traction element” means a rib or a block element defined by having a shape adjacent grooves.

[0026] “Tread Arc Width” means the arc length of the tread as measured between the lateral edges of the tread.

BRIEF DESCRIPTION OF THE DRAWINGS

[0027] The invention will be described by way of example and with reference to the accompanying drawings in which:

[0028] FIG. 1 is a perspective view of the tire system showing pump location (1st embodiment).

[0029] FIG. 2A is a perspective cut away of the tire showing 2-part pump before assembly, and the phantom box shown to illustrate the glue area on inner wall.

[0030] FIG. 2B is a perspective cut away of tire showing 2-part pump assembled with tube inserted through tire wall.

[0031] FIG. 3A is a side view showing pump location in non-compressed area of tire.

[0032] FIG. 3B is a side view showing pump location in a compressed area of tire.

[0033] FIG. 4 is a sectioned view taken from 4-4 of FIG. 3A.

[0034] FIG. 5 is a sectioned view taken from 5-5 of FIG. 3B.

[0035] FIG. 6A is an enlarged view of the pump showing piston locations at rest

[0036] FIG. 6B is an enlarged view of the pump showing viscoelastic material moving the upper piston downward and compressing air between the pistons.

[0037] FIG. 6C is an enlarged view of the pump showing the upper and lower pistons moving and releasing compressed air into tire cavity.

[0038] FIG. 6D is an enlarged view of the pump showing the pistons at rest and the relief valve releasing cavity over pressure to atmosphere.

[0039] FIG. 7 is an exploded cross section of the pump body.

[0040] FIG. 8 is a perspective view of a tire showing the pump location in a second embodiment.

[0041] FIG. 9A is a perspective view of exploded 2-part pump of the second embodiment.

[0042] FIG. 9B is a perspective view of the assembled pump.

[0043] FIG. 10A is a side view showing pump location in non-compressed area of a tire.

[0044] FIG. 10B is a side view showing pump location in a compressed area of tire.

[0045] FIG. 11 is a sectioned view taken from 11-11 of FIG. 10A.

[0046] FIG. 11A is an enlarged view of the pump taken from FIG. 11.

[0047] FIG. 12 is a sectioned view taken from 12-12 of FIG. 10B.

[0048] FIG. 12A is an enlarged view of the pump taken from FIG. 12.

[0049] FIG. 13A is a sectioned view taken from 13A-13A of FIG. 11A with the pump shown at rest.

[0050] FIG. 13B is a sectioned view taken from 13B-13B of FIG. 12A, with viscoelastic material filling the chamber and pushing air through a second one-way valve into the tire cavity.

[0051] FIG. 13C is a sectioned view showing viscoelastic material returning to the upper housing and pulling outside air through the first one-way valve and filling the inner chamber.

[0052] FIG. 13D is a sectioned view showing the relief valve releasing cavity over pressure to the atmosphere.

[0053] FIG. 14A is a perspective view of the pump body insert.

[0054] FIG. 14B is a perspective cross section view of the pump body insert.

[0055] FIG. 14C is a perspective exploded cross section view of the pump body insert.

[0056] FIG. 15 is a sectioned view showing a modified version of a piston pump and compression actuator assembly attached to a tire inner liner.

[0057] FIG. 16 is a bottom perspective view of the piston pump assembly.

[0058] FIG. 17A is an enlarged section view of the membrane pump taken from FIG. 16 showing the pump at rest with outside air entering the inlet chamber.

[0059] FIG. 17B is a view subsequent to FIG. 17A, showing viscoelastic material filling the pump housing chamber and pushing the membrane valve member inward to seal off the inlet, and the pressurized air forcing the outlet valve plug member downward to open the outlet and release air to cavity.

[0060] FIG. 18A is a sectioned isometric view of the pump assembly shown in FIG. 17A.

[0061] FIG. 18B is an exploded view of FIG. 18A.

[0062] FIG. 19A is a schematic view of a rolling tire showing sequential positionment of the pumping assembly as the tire rotates.

[0063] FIG. 19B is a diagrammatic view showing the pump operation at the sequential positions of FIG. 19A.

[0064] FIG. 20 is a graph of pumping air pressure over a time interval as a tire rotates.

DETAILED DESCRIPTION OF THE INVENTION

[0065] Referring to FIGS. 1, 2A, 2B, 3A, 3B, and 4, the subject Self-Inflating Tire System 10 is shown to include a tire carcass 12 of generally conventional construction having a pair of sidewalls 14, a pair of beads 16, and a tread 18. The tire 12 is configured to be self-inflating by inclusion of a pump assembly 20 and coupled compression actuator assembly 19, both of which being attached to the tire in a post-cure assembly procedure. As shown in FIG. 2A, the assembly 19 may be mounted to a sidewall 14 by application of adhesive as shown in phantom as adhesive area 21. The tire 12 mounts conventionally to a rim 22 having a tire mounting surface 26 and an outer rim flange 24 extending from surface 26. The tire 12 is further formed to provide an inner liner component 28 which defines and encloses an internal tire air cavity 30. Adhesive is applied to the sidewall region of the inner liner 28 as depicted by area 21. The tire 12 is formed to further provide a lower sidewall region 32 proximate to the bead areas 16 of the tire. **[0066]** The tire assembly 10 mounts to a vehicle and engages a ground surface 34. Contact area between the tire 12 and the ground surface 34 represents the tire footprint 38. The compression actuator assembly 19 mounts to a sidewall region 42 of the tire 12 having a relatively high flex-deform

mation as the tire rotates in direction 40 against ground surface 34 as shown in FIGS. 3A and 3B. As the tire rotates, the compression actuator assembly 19 and pump assembly 20 will rotate with the tire. The compression actuator assembly 19 will be subjected to compression forces resulting from the sidewall flexing or bending when the assembly 19 is opposite the tire footprint 38 for a purpose explained below. FIG. 3A and section view FIG. 4 show the compression actuator assembly 19 and pump assembly 20 location in a non-compressed area of the tire 12 while FIG. 3B and section view FIG. 5 show the assemblies 19 and 20 in a compressed area of the tire 12. In the position of FIG. 5, the compression actuator assembly 19 will be subjected to the compression forces 36 generated within tire footprint 38. The tire rotates in direction 40 and in the opposite direction during normal operation of a vehicle. As such, the coupled assemblies 19, 20 rotate with the tire in both directions and are subjected to compression forces generated within the sidewall 14 in both forward and reverse tire rotational directions.

[0067] In reference to FIGS. 2A, 2B, 4, 5, 6A, 6B, 6C, 6D, and FIG. 7, the compression actuator assembly 19 includes an elongate hollow containment body 44 formed from a resilient deformable material composition such as thermoplastic resin and/or rubber compound. The body 44 so composed is thus capable of reciprocally and resiliently undergoing a cyclic deformation into a deformed state and recovery into an original non-deformed state when subjected to bending force. The elongate body 44 as shown in FIG. 2A, 4, is sized and shaped to generally follow the inner contour of the tire sidewall 14 from the tread region 18 to the bead area 16. The hollow, elongate form of the containment body 44 may be affixed to the inner liner 28 of the tire at adhesive region 21 or modified in form for incorporation into the tire sidewall as will be explained.

[0068] The containment body 44 includes an enclosed central reservoir cavity 46 filled with a volume of non-compressible medium 48. The medium may be in either foam or fluid form. Medium suitable for use in the subject application may include, but is not limited to water with an antifreeze additive. The medium 48 is enclosed by the body 44 within the cavity 46 and generally fills the cavity 46. An outlet conduit 50 is provided to the body 44, the conduit 50 extending generally axially from the body 44 and containing an inner outlet conduit bore 51 through which a displaced quantity of medium 48 may travel in reciprocal directions. The conduit 50 extends to a leading end surface 60.

[0069] Positioned as shown in FIGS. 2A, 2B, 4, 5, the containment body 44 is subjected to bending forces from the tire sidewall 14 as the region of the sidewall to which body 44 attaches passes proximate to the tire footprint and is compressed by forces 36 on the tread 18 (FIGS. 3B, 5). Bending forces 36 applied to bend the sidewall region 14 serve to cause a commensurate bending deformation 52 of the medium containment body 44 as shown in FIGS. 6A, 6B, 6C and 6D. The deformation 52 introduced into the body 44 by bending tire sidewall 14 proximate to the tire footprint 38 causes displacement of a quantity 54 of the medium 48 along the outlet conduit 50 in the direction shown at arrow 56 of FIG. 6B. Pressure from the displaced medium quantity 54 acts as a pressure actuator to the pumping assembly 20 as will be explained. When the tire sidewall region to which body 44 attaches leaves a proximal position to the tire footprint 38, such as the position opposite the tire footprint as depicted in FIG. 6A, the compression force in the sidewall is removed/

lessened, causing a commensurate removal/lessening of bending force into the containment body 44. Removal of bending force in the containment body 44 causes the body 44 to resume its original, non-deformed state as shown in FIG. 4 and the medium 48 to recede within the conduit 50 in direction indicated at arrow 58. The cycle of sidewall bending an unbending translates into a cyclic deformation, restoration of the containment body 44 as the tire rotates in either a forward or reverse direction and generates a cyclic compression force from displaced medium volume 54 along the conduit 50. The compression force from the displaced medium quantity 54 is in the direction 56 and is proportionate to the pressure generated by the displaced quantity of the non-compressible medium 48.

[0070] Referring to FIGS. 6A-D and 7, the pump assembly 20 is affixed to the tire carcass 12 at a location adjacent the compression actuating assembly 19, preferably in an inward radial direction relative to assembly 19. The pumping assembly 20 includes a hollow compressor body 62 of generally tubular form having an internal axially oriented air chamber 64 which extends to a lower chamber end 65. The air chamber 64 is accessible through an inlet conduit 66 which intersects the air chamber 64 at an inlet opening 67. The body 62 and conduit 66 are formed of a rigid material such as metal or plastic. Conduit 66 is generally elongate and tubular having an internal axial passageway 68 communicating with the air chamber 64 via opening 67. On the opposite side of the body 62 an outlet conduit 70 of generally tubular form having an axial passageway 72 extending there through and communicating with the air chamber 64 at outlet opening 73. The inlet conduit 66 and the outlet conduit 70 are axially offset, with conduit 66 closest to the actuating assembly 19 and conduit 70 farthest away from assembly 19.

[0071] A first cylindrical piston member 74 is sized for sliding position within an upper end of the axial air chamber 64 of the compressor body 62 and includes a blind axial bore 76 extending into an inward piston end surface 75. A recess 78 extends through an outward facing piston side and functions as a collector for the air which will come out of the valve (assembly 96). It will connect the valve and the canal inside the piston whatever is the angular position of the piston. Extending into a piston side opposite the recess 78 is a relief valve intake channel 80 that communicates with the blind bore 76.

[0072] A second cylindrical piston member 82 is sized for sliding receipt within a lower end of the axial air chamber 64 of the compressor body 62. The second piston 82 includes a cylindrical body 84 and an outward spring-compressing post arm 86 extending from the body 84 to an outward end 85. A blind bore 88 extends into the end surface 85 of the post arm. A transversely oriented inlet channel 90 extends through a side of the post arm 86 to communicate with the blind bore 88. A large coil spring 94 is provided sized to fit within the lower end 65 of the air chamber 64 within the compressor body 62. A smaller coil spring 92 is further provided and seats against surface 77 within the blind bore 76 of the first piston 74. A pressure regulating relief valve assembly 96 mounts within an inlet chamber 99 of an inlet tubular sleeve 98 extending from the compressor body 62. The sleeve 98 includes an inlet axial passageway 97 extending from the chamber 99 to the air channel 64 of the compressor body 62. The assembly 86 includes a circular body 100 having a tubular entry conduit 102 extending outward. A through bore 104 extends through the conduit 102 and body 100. A disk-shaped seal component

106 is positioned within the chamber **99** inward of the circular body **100** and is outwardly biased against the circular body **100** by a coil spring **108** seated within the chamber **99**.

[0073] At the opposite side of the compressor body and affixed to the inlet conduit **66** is an inlet tube **110** having an annular abutment flange **112** at an inward end and an axial passageway **114** extending from an outward tube end **115** through the tube **110** to the inlet opening **67** of the compressor body **62**. Seated within the tube passageway **114** proximate the outward tube end **115** is a porous filter component **116** that functions to filter out particulates from entering the tube passageway **114**. The pumping assembly **20** is enclosed within an outer sheath or casement **128** that is shaped to complement a radially lower region of the sidewall **14** and extends from the compression actuating body **44** to a location opposite to a tire bead region. The casement **128** is formed from a protective material that is suitable for attachment to the tire innerliner by adhesive such a rubber matrix.

[0074] With respect to FIGS. 4, 5, 6A, and 7, the compression actuation assembly **19** and the pump assembly **20** are connected together as shown for incorporation into the tire carcass **12**. The actuation assembly **19** is incorporated into a region of the sidewall **14** of the tire carcass **12** that experiences a high bending load as the tire rotates. The assembly **19** may either be incorporated within the sidewall **14** or affixed to the sidewall **14** by adhesive as shown. In the externally mounted assembly approach shown, the containment body **44** is complementarily shaped and curved as the sidewall region to which it attaches and extends generally from a radially outward end **130** proximate the tread region **18** radially inward along the sidewall attachment region to a radially inward end **132** proximate a bead region. The pumping assembly **20** attaches to the inward end **132** of the assembly **19** by adhesive or other suitable attachment means. The pumping assembly **20** is sheathed within an outer casing **128** composed of a tire compatible material such as rubber. The coupled compression actuation assembly **19** and pumping assembly **20** mount by adhesive attachment to the inner liner **28** of the tire carcass **12** with the assembly **20** proximate to the carcass bead/lower sidewall region **32**. So positioned, the inlet tube **110** to the assembly **20** projects in an axial direction through the tire sidewall **14** to an external air-accessible outer tire sidewall side location. Positionment of the tube **110** is preferred above the rim flange **24** so that the rim flange **24** will not interfere with intake air entering the tube **110** of the pumping assembly **20**.

[0075] As will be appreciated, the outlet conduit **50** of the compression assembly **19** couples into the upper end of the compressor body **62** as the outlet conduit **50** of actuator body **44** is received in sealing engagement with the upper end of the compressor body **62**. The compressor body **44** abuts against the casing **128** containing the pumping assembly **20**. Once the assemblies **19** and **20** are attached together, they may be attached to a region of the tire sidewall **14** as shown in FIGS. 2A and 4 and described previously. The first and second pistons **74**, **82** are mechanically coupled as the post projection **86** from the second piston **82** projects into the bore **76** and against the spring **92** seated within bore **76**. Axial movement of the pistons **74**, **82** are thus synchronous within the air chamber **44** in both radial directions.

[0076] FIGS. 6A-D depict the operation in sequence of the pump assembly **20** and compression actuator assembly **19**. FIG. 6A shows the pump assembly **20** with the pistons **74**, **82** in the at rest positions. The position shown correlates with a

position of the assemblies **19**, **20** mounted to a rolling tire as shown in FIG. 3A at a rotational position opposite to the tire footprint. The sidewall **14** area supporting assemblies **19**, **20** when opposite the tire footprint (FIG. 6A) is not flexed or bent from the tire contact with ground surface. Accordingly, the compression actuator body **44** has a bending deformation **52** that generally correlates with the curvature of the unbent sidewall **14**. The medium **48** enclosed within the body **44** is generally at rest and contacts the leading medium surface **60** within conduit **50** against the end of piston **74**. The outer piston **74** is retracted toward the outer end of the air chamber **64** under spring bias from coil spring **92**.

[0077] In the "at rest" position of FIG. 6A, the piston **74** is axially above the intake opening **67** if the inlet conduit **66**. As a result, air from outside of the tire is admitted through the filter **116** and into the bore **114** of the inlet conduit **110** from which it channels through the opening **67** of the inlet conduit **66** and into the air chamber **64**. Arrows **118** show the path of inlet air travel. The piston **82** is in an axially raised position within the body air chamber **64** and blocks off the outlet opening **73** of the outlet conduit **70**. Springs **92**, **94** are in respective uncompressed conditions. The relief valve assembly **96** is generally in a closed position so long as the pressure within the tire cavity remains below a preset recommended inflation pressure. In the closed position, the spring **108** biases the stop disk head **106** against the opening **102** through conduit body **100**. Should the pressure within the tire cavity exceed a pressure threshold, the air pressure from the cavity will force the stop **106** away from the conduit opening **102** and allow air to escape from the tire cavity.

[0078] As the region of the sidewall **14** carrying the assemblies **19**, **20** rotates into opposition to the tire footprint, the sidewall **14** flexes and bends, causing a commensurate flexing of the compression actuator body **44** as shown at numeral **52** of FIG. 6B. FIG. 6B shows that the viscoelastic material **48**, having non-compressible material properties, in response to the bending of body **44** is forced lower within the outlet conduit **50** and exerts a downward pressure on the first piston **74** as indicated by arrow **56**. The leading end surface **60** of the medium **48** bears against the outward surface of the piston **74** and overcomes the resistance of coil spring **92** by compression of spring **92** to allow piston **74** to move lower into the air chamber **64**. In so doing, the piston **74** moves into a position blocking air intake into the chamber **64** through the intake tube **110** and compresses the volume of air within the chamber **64**. Increased pressure of air within the chamber **64** forces the second piston **82** lower within the air chamber **64** and compresses the coil spring **94**.

[0079] When the piston **82** has moved a sufficient axial distance within the air chamber **64**, the outlet opening **73** into the outlet conduit channel **72** ceases to be obstructed by the piston **82** as shown in FIG. 6C and FIG. 5. Pressurized air from the chamber **64** is thus forced through the channel **72** and into the tire cavity in the direction indicated by arrow **126**. When the pumping of air is complete and pressure within chamber **64** against the second piston **82** is discontinued, the piston **82** is forced axially upward and back into the at-rest position shown both in FIG. 6D and FIG. 6A.

[0080] As seen from FIG. 6D, once removal of the quantity of pressurized air within the chamber **44** into the tire cavity is complete, with further rotation of the tire the assemblies **19**, **20** with the attachment region of sidewall **14** leave the high stress position opposite the tire footprint and the tire sidewall region resumes an unstressed curvature as shown in FIG. 2A

and 3A. The return of the sidewall 14 to an original curvature configuration outside of the tire footprint is accompanied by and synchronous with a return of the actuator body 44 to an unbent configuration. As the actuator body 44 resumes its original curvature, and commensurate with the end of the pumping cycle of air from air chamber 64, piston 82 moves axially upward under the influence of spring 94 which forces the piston 74 in a radial upward movement. The viscoelastic medium 48 recedes into the original containment form of the body 44 and the pumping of air into the tire cavity is discontinued until the assemblies 19, 20 rotate with the tire back into alignment opposite the tire footprint. With each revolution, the pumping of air from chamber 64 into the tire cavity occurs in cyclic fashion. It will be appreciated that the operation of the air pumping action is independent of the direction of tire revolution and will occur in either a forward or reverse tire travel.

[0081] FIG. 6D also depicts view of the pump assembly 20 wherein pistons 74, 82 are in the at-rest position while the relief valve assembly 96 functions to vent tire cavity over-pressure air to the atmosphere. The relief valve assembly 96 is generally in the closed position shown in FIGS. 6A through 6C and only opens when the air pressure within the tire cavity exceeds a recommended upper threshold. In such an event, the stop body 106 is forced laterally out of sealing engagement against with conduit flange 100 and overcoming biased resistance from the coil spring 108. The passageway 104 is thus opened to allow over-pressure air from the tire cavity through the conduit 102 and the relief channel 80 within piston 74 as indicated by directional arrow 124. The pressurized air follows a path through the blind bore 76 of piston 74, through the blind bore 88 within the coupling post 86 of piston 82, and into the bore 114 of tube 110 as indicated by directional arrow 122. The expelled over-pressure air exhausts to the atmosphere through filter unit 116 and out of tube end 115. The exhaust of air through filter 116 operates to clean particulates from the filter as well as correcting the over-pressure within the tire cavity. Once the tire cavity pressure is reduced below the threshold recommended pressure, spring 108 will uncoil and pressure the stop body 106 against the conduit flange end 100 and thus close off the tire cavity until over-pressure exhausting of air from the tire cavity is necessary.

[0082] Referring to FIGS. 9A, 9B, 10A, 10B, 11A, 11B, 12A, 12B, 13A through 13D, 14A through 14C, inclusive, an alternative embodiment of a pump and compression actuating assembly 134 is shown including a compression actuating assembly 136 coupled to a pump assembly 138 to form an L-shaped insert body 140. The body 140 mounts to a lower sidewall region of a tire carcass 12 proximate to a bead region 16 as shown in FIGS. 10A, 10B. The compression actuating assembly 136 has a deformable hollow body 142 forming a containment chamber 144 communicating with an outlet portal 146. The hollow body 142 is configured at ninety degrees into an L-shape having upright body portion 148 extending from horizontal body portion 150. A viscoelastic medium on non-compressible material 152 fills the containment chamber 144 as previously described in reference to the first embodiment.

[0083] The pump assembly 138 likewise forms an L-shaped encapsulation sheath body 154 affixed to the L-shaped compression actuating body 142. Body 154 includes an upright body portion 158 extending from horizontal body portion 156. An outlet orifice 160 is positioned

within the horizontal portion 156 and an inlet orifice 162 in a side facing region of the portion 156. An outlet conduit 168 is attached to the outlet orifice 160 and includes an axial passage 170 extending to a remote end 170.

[0084] FIGS. 10A and 10B show the mounting of the L-shaped pump assembly 134 to a tire at a lower sidewall region proximate to a tire bead location. As with the embodiment previously described, the pump assembly 134 rotates with the tire from a location outside of proximity to the tire footprint (FIG. 10A) into a position opposite the tire footprint (FIG. 10B) with each tire revolution. As with the first embodiment, the assembly 134 body 140 is bent by stress induced from a bending of the tire sidewall as the rotational position of assembly aligns opposite the tire footprint (FIG. 10B). FIGS. 11A and 11B show the relative position of the assembly 134 within the lower region of sidewall 14 where the assembly body 140 is subjected to high bending forces as the tire rotates. The outlet end 172 of the outlet conduit 168 extends through the tire wall to the cavity 30 of the tire. Compressed air from the compressor body 174 travels along passage 170 and into the tire cavity to keep the inflation pressure of the tire at a desired level.

[0085] FIG. 11A is a sectioned view taken from a pump location in a non-compressed area of the tire as shown in FIG. 10A. FIG. 11B is an enlarged view of the pump assembly 134 of FIG. 11A. FIG. 12A is a sectioned view taken from a pump location in a compressed area of the tire as shown in FIG. 10B. FIG. 12B is an enlarged view of the pump assembly 134 as depicted in FIG. 12.

[0086] With reference to FIGS. 13A through 13D and 14A through 14C, the compression body 174 has an internal elongate compression chamber 176 and a pair of one-way ball valves 178, 180 positioned at opposite ends of the chamber 176. Each of the valves 178, 180 is of a type commercially available and each includes a stop ball component 182 biased by a coil spring against a seat 186. In addition, a relief pressure by-pass passage 188 is provided within the compression body 174 in parallel to the chamber 176. Seated within the passage 188 is a one-way ball valve 190 of similar configuration as the ball valves 178, 180. The passageway 188 and the chamber 176 extend in parallel between the outlet conduit 168 at one end of the body 174 and the inlet opening 162 at an opposite end.

[0087] Operation of the first alternative form of the pumping assembly 138 proceeds as follows. The L-shaped body 136 is embedded or affixed to the tire carcass in the position shown generally by FIGS. 10A and 10B. So positioned, as the tire sidewall to which the assembly 138 undergoes bending, the compression actuating body 142 will likewise undergo bending. FIGS. 13A and 13D show the pump assembly 138 in an "at-rest" status; that is, with the assembly 138 not under bending stress as the tire position of FIG. 10A represents. The ball valves 178, 180 are in a seated closed position. The valves 178, 180 are selected to open at a desired threshold pressure as will be explained.

[0088] In the at-rest position, air within the compression chamber 176 is unpressurized. The relief valve 190 is likewise seated and closed and will remain so unless the air pressure within the tire cavity 30 is over a desired pressure threshold. In an over-pressure situation, the valve 190 will open and allow air to escape the cavity 30 through passage 188 and exhausted from the inlet opening 162 to the atmosphere. The compression medium 152 is confined to the compression body chamber 176 and the inlet conduit 164 is clear.

[0089] FIG. 13B and FIG. 12B show the pump assembly 134 when the tire has rotated the assembly into a position opposite the tire footprint (FIG. 10B). The compression body 174 is then subjected to a bending force and is deformed. The bending of the body 174 forces the viscoelastic material 152 from the chamber 144 into and along the conduit 164 (direction 192) which, in turn, acts to compress air within the compression chamber 176. Pressure from the compressed air opens the valve 180 by unseating valve ball 182 and air is channeled into the outlet conduit 168 to the tire cavity 30.

[0090] FIG. 13C represents the pump assembly 134 after further rotation of the tire occurs, positioning the pump assembly away from the tire footprint such as the position shown in FIG. 10A. The removal of bending force to the body 174 allows the resilient body to return to its original configuration and chamber 176 into a form allowing the medium 152 to recede back from the conduit 164. The transfer of pressurized air from the chamber 176 draws air into the chamber 176 from the atmosphere through the unseating of one-way valve 178 from its seat 186. Air drawn into the chamber 176 forces the medium 152 back into the chamber 144 as shown at arrow 194. Valve 180 has reseated itself and blocks off air from exiting the chamber 176. A filter member 198 within the inlet end of the chamber 176 keeps particulates from entering the chamber 176.

[0091] FIG. 14D shows the assembly 134 back into its original at-rest position. In the event that an over-pressure situation arises within the tire cavity, the tire air pressure will cause the one-way valve 190 to open and air to flow in direction 196 back through the passage 188 for exhaust through filter 198 and into the atmosphere. The back flow of air through filter 198 helps to keep the filter clean. As with the first embodiment, the pump assembly 134 operates in either direction of tire rotation and pumps air into the tire during each cycle of tire revolution.

[0092] With reference to FIGS. 15, 16, 17A,B, 18A, and 18B, a tank-based hydraulic pump assembly 200 is shown in a commercially viable configuration. The assembly 200 is functionally analogous to the embodiment of FIGS. 4 and 7 as previously discussed. Assembly 200 includes an air compressor body 202 having an elongate axial bore or chamber 204. The chamber 204 is subdivided into a rearwardly located membrane chamber 206 at a rearward end 208 of the body 202. End 208 of the body 202 has external screw threads 210 for assembly purposes. Adjacent to the rearward membrane chamber 206 is a medial air compression chamber 212. Positioned at the chamber 212 is a tubular inlet air channel 214 extending through a sidewall of the body 202 into communication with chamber 212. An external inlet sleeve 216 extends from the body 202 opposite the channel 214 and encloses a throughbore 218. Assembly screw threads 220 are positioned within the bore 218.

[0093] Separating chambers 206 and 212 along the bore 204 is an annular membrane abutment shoulder 222. Adjacent to the chamber 212 at an opposite end along the bore 204 is a concave chamber end wall 224. Inwardly tapering sidewalls 223 define the chamber 212 and extend from the annular abutment shoulder 222 to end wall 224. A circumferential array of through apertures 227 are positioned within the concave end wall 224. A circular outlet stop assembly 226 seats within the body 202 on the opposite side of the concave end wall 224. A pair of annular detent channels 230, 232 are formed within an outlet bore 228 at end 231 of the compressor

body 202. The outlet stop assembly 226 seats within the forwardmost channel 230 in position adjacent the compression chamber end wall 224.

[0094] A head cap member 234 having an axial internal chamber 236 attaches to end 208 of the body 202. The cap member 234 includes an outer flange 238 and an annular detent channel 239 adjacent cap flange 238. The cap member 234 has a cylindrical body portion 240 that is internally threaded by screw threads 242. Extending through a sidewall of the cap member 234 is a fill conduit 244 having a through-bore 246 and internal screw threads 248. A screw member 250 includes threads 252 that thread into the fill conduit 244.

[0095] An inlet conduit 254 has a cylindrical body 256 and an end 258 that threads into the inlet sleeve 216. An enlarged head 260 is integrally joined to body 256 and a throughbore 262 extends axially through the inlet conduit 254 end to end. The outlet stop member 226 includes a circular snap-ring body 264 dimensioned for close receipt within the outlet bore 228 and formed of suitably rigid material such as plastic. The snap-ring body 264 is frictionally inserted and seats within the annular detent channel 230. The body 264 has a circular array of spaced apart apertures 266 extending therethrough and a slideably mounted central plug member 268 disposed within a center aperture of the body 264. The plug member 268 has a body 272 including an enlarged circular sealing disk at a forward end positioned opposite to the apertures 227 within the concave end wall 224 of the air compression chamber 212. The body 272 resides within the center aperture of the snap-ring body 264. An annular flared spring flange portion 274 is formed at the rear of the body 272. The plug member 268 is formed from a sufficiently resilient elastomeric material such as plastic so as to be compressible in an axial direction within the center aperture of snap-ring body 264. Accordingly, the plug member 268 in the uncompressed state positions the sealing disk 270 in a sealing engagement against the apertures 227. Under air pressure, the sealing disk 270 moves rearward into an "open" position wherein the apertures 227 are unobstructed. Movement of the plug member body 268 between the uncompressed "closed" position and the compressed "open" position is controlled by air pressure within the compression chamber 212 as will be explained.

[0096] A circular retaining spring clip 276 is positioned within the detent channel 232 and is operative to hold the outlet stop member 226 within its respective channel 230. An elastomeric membrane component 278 is provided of generally circular disk-shape. The component 278 has an annular ring body 280 which circumscribes a central circular flexible membrane panel 282. The ring body 280 of component 278 is of sufficiently rigid material composition such as rubber to hold its form while the membrane panel 282 is sufficiently thin and resiliently flexible to move between a bulging configuration and a non-bulging configuration. Thus, the membrane panel 282 is operatively capable of bulging outward under rearward air pressure and sufficiently resilient to revert back to an original orientation when such pressure is removed.

[0097] The membrane component 278 is seated within the membrane chamber 206 of the compressor body 202 against an internal annular body shoulder 283. An annular retention collar 284 is positioned within the chamber 206 behind the membrane component 278. The head cap 234 is assembled by screw thread engagement to the rear of the compressor body 202 as shown. In the assembled condition, the axial compression

sion chamber 206, a central bore chamber 286 of the membrane component 278, and the axial chamber 236 of the head cap 234 are in co-axial alignment.

[0098] As with the previously discussed embodiment of FIGS. 2A and 7, the tank-based pump assembly 200 as shown in FIGS. 17A and 17B attaches to an actuator tank or compression actuating body 296 by the means of a forward coupling rib 298 which engages into the detent channel 239 of the head cap component 234. The compression actuating body 296 contains an internal reservoir 300 filled with a non-compressible medium 302 such as an anti-freeze and water mix. The forward outlet of the body 296 thus is in medium fluid-flow communication with the internal chamber 236 of the head component 282 and the internal axial membrane chamber 206.

[0099] FIGS. 15, 17A, 17B, 18A illustrate the pump assembly 200 in the assembled condition with the inlet tube 254 screw assembled into the inlet sleeve 216 of body 202; the outlet stop member 226 positioned within the outlet bore 228 against the apertures within end wall 224 of the chamber 212; retainer clip 276 in a retention position within the outlet bore 228. The compression actuating body or tank 296 is attached to the rearward end of the head cap and filled with medium 302 via fill port 244 after the screw member 250 is removed. Screw member 250 is then reinserted into the fill port 244 to encapsulate the medium within the reservoir 300. In containment, the medium fills the head cap member chamber 236 and abuts against a rearward surface of membrane panel 282.

[0100] The assembly 200 with the compression actuating body 296 is affixed to the inner liner 28 of a tire as shown in FIG. 15. The inlet tube 254 extends through the tire sidewall and presents the outer end of throughbore 262 to the external atmosphere. The outlet bore 228 exits into the tire cavity to direct replenishment air into the cavity as required.

[0101] FIG. 17A shows the pump assembly 200 in an at-rest condition, with outside air entering the inlet chamber as indicated by arrows 288. The membrane or diaphragm panel 282 of the membrane body 280 is in an at-rest, non-extended state in which the medium 302 behind the membrane panel 282 exerts only a nominal pressure against the panel. So positioned, the membrane panel 282 does not block the inlet of air from the inlet channel 214 into the compression chamber 212. In the at-rest position of FIG. 17A, air within the chamber 212 is in a non-compressed state. The sealing disk 270 of the plug member 268 is positioned against the concave end wall 224 of the air compression chamber 212 and, so positioned, obstructs air from exiting the chamber 212 through the apertures 227. Air is thus contained in a non-compressed state within the chamber 212. In the at-rest condition, accordingly, the pump assembly 200 is not pumping air into the tire cavity.

[0102] FIG. 17B is a view subsequent to FIG. 17A, wherein a deformation of the compression actuating body 296 acts to displace a quantity of the viscoelastic medium 302 under pressure through the cap member chamber 236, the retention collar bore 204, and against a rearward surface of the membrane panel 282. The applied pressure from the displaced medium against panel 282 forces the panel outward into a protruding or bulging condition as indicated by arrow 290. As a result, the air within compression chamber 212 is compressed. Increased air pressure within the compression chamber 212 forces the sealing disk 270 of the plug member 268 outward, placing the plug member 268 into a state of compression against the support members 274. Movement of the

sealing disk into the open position serves to uncover the apertures 227 and allowing air to pass from the chamber 212, through the apertures 266 of the snap-ring 264, through the outlet bore 228, and into the tire cavity. It will further be noted that the bulging protrusion of the membrane panel 282 further acts to block off the inlet channel 214 during the pumping cycle operation.

[0103] When the air pressure within the compression chamber 212 has diminished, the compression of plug member 268 releases and forces the sealing disk 270 back into the "sealing" or "closed" position of FIG. 17A. The membrane panel resumes its configuration of FIG. 17A as the medium behind the panel 282 recedes back into its containment reservoir 300 and the compression actuating containment body 296 resumes its non-deformed configuration. Movement of the membrane panel back into a "non-protruding" configuration opens the inlet channel 214, thus allowing outside air to be admitted into the compression chamber 212. The cyclical intake of air, compression of air, and exhausting of compressed air into the tire cavity occurs with every tire revolution.

[0104] It will be appreciated that the disk 270 is preferably formed of plastic and has a minimal travel to open, such as but not limited to 0.010 to 0.020 inches. When assembled to the snap-ring 264 it is forcing the seal end against the openings 227 in the compression chamber end. The six holes 266 through the snap-ring 264 operate to move a large amount of air from the compression chamber 212 to the tire cavity during fast tire rotation.

[0105] FIGS. 17A, 17B, 19A and 19B show the operational cycle of the pump assembly 200 as a tire rotates against a road surface. The flexing of the tire sidewall causes a deformation of the compression actuating body 286 as the body 286 enters a position opposite the tire footprint. T1-T0 show the position of the pump entering and leaving the footprint vicinity. FIG. 19B shows the operation/location of the membrane panel 282 at each of the stages T1-T0. The pump assembly 200 accordingly cyclically alternatively closes and opens inlet and outlet ports to effect pressurized air replenishment of the tire during rotational operation of the tire. FIG. 20 shows in graphic form cyclical pressure level variance within the air compression chamber over time.

[0106] Variations in the present invention are possible in light of the description of it provided herein. While certain representative embodiments and details have been shown for the purpose of illustrating the subject invention, it will be apparent to those skilled in this art that various changes and modifications can be made therein without departing from the scope of the subject invention. It is, therefore, to be understood that changes can be made in the particular embodiments described which will be within the full intended scope of the invention as defined by the following appended claims.

What is claimed is:

1. An air-maintenance tire system comprising:
 - a tire having a tire carcass comprising a tire cavity defined by a tire inner liner, first and second sidewalls extending respectively from first and second tire bead regions to a tire tread region;
 - compression actuator means mounted to the tire carcass configured for operative actuation by tire deformation during a tire revolution,
 - a pump assembly affixed to the tire carcass and comprising a compressor body affixed to the compression actuator means and having an internal air chamber, the air cham-

ber having an inlet opening for admitting air into the internal air chamber and an outlet opening for conducting air from the internal air chamber to the tire cavity; the air compressor body further comprising a flexible membrane member located within the internal air chamber and operatively deforming within the internal air chamber responsive to contacting engagement with the compression actuator means between an open position relative to the inlet opening wherein permitting air flow from the inlet opening into the air chamber and a closed position relative to the inlet opening wherein obstructing air flow from the inlet opening into the air chamber, wherein the membrane member during operational deformation between the open and closed positions compressing a volume of air within the air chamber.

2. The air-maintenance tire system of claim 1, wherein further comprising an outlet valve member within the air chamber and moving along the air chamber responsive to air pressure within the air chamber reaching a preset threshold between an open position wherein permitting air flow from the air chamber into the outlet opening and a closed position wherein obstructing air flow from the air chamber into the outlet opening.

3. The air-maintenance tire system of claim 2, wherein the membrane valve member and the outlet valve member are positioned at opposite ends of the air chamber.

4. The air-maintenance tire system of claim 3, wherein further comprising an inlet conduit extending through the tire between the inlet opening and an outward facing side of the tire.

5. The air-maintenance tire system of claim 4, wherein further comprising an outlet conduit extending from the outlet opening to the tire cavity.

6. The air-maintenance tire system of claim 3, wherein the compression actuator means comprising a hollow containment body formed from a resilient deformable material composition and containing a quantity of a non-compressible medium, the containment body affixed to a relatively high flex-deformation region of the tire carcass and the containment body reciprocally transforming between a deformed state and a non-deformed state responsive to deformation and recovery of the tire high flex-deformation region in a rolling tire, respectively;

and wherein the actuator means containment body in the deformed state displacing a pressurized displaced quantity of the non-compressible medium, the pressurized displaced quantity of the non-compressible medium operative to generate a compression force against a membrane valve member surface to move the membrane valve between the open and closed positions within the air chamber.

7. The air-maintenance tire system of claim 6 wherein the containment body operationally undergoes a cyclic transformation between the deformed state and the non-deformed state during a tire revolution against a ground surface.

8. An air-maintenance tire system comprising:

a tire having a tire carcass comprising a tire cavity defined by a tire inner liner, first and second sidewalls extending respectively from first and second tire bead regions to a tire tread region,

compression actuator means mounted to the tire carcass configured for operative actuation by tire deformation during a tire revolution,

a pump assembly affixed to the tire carcass and comprising a compressor body affixed to the compression actuator means and having an internal air chamber, the air chamber having an inlet opening for admitting air into the internal air chamber and an outlet opening for conducting air from the internal air chamber to the tire cavity; the air compressor body further comprising a membrane valve member and an outlet valve member located within and at opposite respective ends of the internal air chamber, the membrane valve member and the outlet valve member moving within the internal air chamber responsive to actuation by the compression actuator means between respective open and closed positions, whereby cyclically opening and closing the inlet and the outlet openings during an air compression cycle comprising air intake, air compression, and air discharge within the air chamber.

9. The air-maintenance system of claim 8, wherein the membrane valve member in the open position relative to the inlet opening permitting air flow from the inlet opening into the air chamber and the piston valve member in the closed position relative to the inlet opening obstructing air flow from the inlet opening into the air chamber, and wherein the membrane valve member during movement between the open and closed positions operatively compressing a volume of air within the air chamber.

10. The air-maintenance tire system of claim 1, wherein the outlet valve member in the closed position relative to the outlet opening is operative to move to the open position responsive to air pressure within the air chamber reaching a preset threshold wherein permitting air flow from the air chamber into the outlet opening.

11. The air-maintenance tire system of claim 10, wherein further comprising an inlet conduit extending through the tire between the inlet opening and an outward facing side of the tire.

12. The air-maintenance tire system of claim 11, wherein further comprising an outlet conduit extending from the outlet opening to the tire cavity.

13. The air-maintenance tire system of claim 10, wherein the compression actuator means comprising a hollow containment body formed from a resilient deformable material composition and containing a quantity of a non-compressible medium, the containment body affixed to a relatively high flex-deformation region of the tire carcass and the containment body reciprocally transforming between a deformed state and a non-deformed state responsive to deformation and recovery of the tire high flex-deformation region in a rolling tire, respectively; and wherein the actuator means containment body in the deformed state displacing a pressurized displaced quantity of the non-compressible medium, the pressurized displaced quantity of the non-compressible medium operative to generate a deformation force against a membrane valve member surface to deform the membrane valve member between the open and closed positions within the air chamber.

14. The air-maintenance tire system of claim 13 wherein the containment body operationally undergoes a cyclic transformation between the deformed state and the non-deformed state during a tire revolution against a ground surface.

- 15.** An air-maintenance tire system comprising:
a tire having a tire carcass comprising a tire cavity defined by a tire inner liner, first and second sidewalls extending respectively from first and second tire bead regions to a tire tread region;
compression actuator means mounted to the tire carcass configured for operative actuation by tire deformation during a tire revolution,
a pump assembly affixed to the tire carcass and comprising a compressor body affixed to the compression actuator means and having an internal air chamber, the internal air chamber having an inlet opening for admitting air into the internal air chamber and an outlet opening for conducting air from the internal air chamber to the tire cavity; the air compressor body further comprising a membrane valve member deforming into a deformed state within the internal air chamber responsive to actuation by the compression actuator means to compress air within the internal air chamber.
- 16.** The air-maintenance tire system of claim **15**, further comprising an outlet valve member located within the internal air chamber, the outlet valve member operatively moving relative to the internal air chamber between an open position permitting a flow of compressed air from the internal air chamber into the outlet opening and a closed position obstructing a flow of compressed air from the internal air chamber into the outlet opening.
- 17.** The air-maintenance tire system of claim **16**, wherein the outlet valve member comprises a plug member operatively fitting within the outlet opening in the closed outlet valve member position and the plug member operatively dislodging from within the outlet opening in the open outlet valve member position.
- 18.** The air-maintenance tire system of claim **17**, wherein the compression actuator means comprising a hollow con-

tainment body formed from a resilient deformable material composition and containing a quantity of a non-compressible medium, the containment body affixed to a relatively high flex-deformation region of the tire carcass and the containment body reciprocally transforming between a deformed state and a non-deformed state responsive to deformation and recovery of the tire high flex-deformation region in a rolling tire, respectively;

and wherein the actuator means containment body in the deformed state displacing a pressurized displaced quantity of the non-compressible medium against the membrane valve member to operatively place the membrane valve member in the deformed state.

19. The air-maintenance tire system of claim **15**, wherein the compression actuator means comprising a hollow containment body formed from a resilient deformable material composition and containing a quantity of a non-compressible medium, the containment body affixed to a relatively high flex-deformation region of the tire carcass and the containment body reciprocally transforming between a deformed state and a non-deformed state responsive to deformation and recovery of the tire high flex-deformation region in a rolling tire, respectively;

and wherein the actuator means containment body in the deformed state displacing a pressurized displaced quantity of the non-compressible medium against the membrane valve member to operatively place the membrane valve member in the deformed state.

20. The air-maintenance tire system of claim **19**, wherein the containment body operationally undergoes a cyclic transformation between the deformed state and the non-deformed state during a tire revolution against a ground surface.

* * * * *