



(11) **EP 2 842 774 A1**

(12) **EUROPEAN PATENT APPLICATION**

(43) Date of publication:
04.03.2015 Bulletin 2015/10

(51) Int Cl.:
B60C 23/12 (2006.01)

(21) Application number: **14182070.4**

(22) Date of filing: **25.08.2014**

(84) Designated Contracting States:
AL AT BE BG CH CY CZ DE DK EE ES FI FR GB GR HR HU IE IS IT LI LT LU LV MC MK MT NL NO PL PT RO RS SE SI SK SM TR
Designated Extension States:
BA ME

(72) Inventor: **Hinque, Daniel Paul Luc Marie**
B-6720 Habay-la-Neuve (BE)

(74) Representative: **Kutsch, Bernd**
Goodyear S.A.
Patent Department
Avenue Gordon Smith
7750 Colmar-Berg (LU)

(30) Priority: **29.08.2013 US 201314013829**

(71) Applicant: **The Goodyear Tire & Rubber Company**
Akron, Ohio 44316 (US)

(54) **Tire having a pump and valve assembly**

(57) A tire having a pump and valve assembly is disclosed. The tire comprises a tire cavity and a first and second sidewall extending respectively from first and second tire bead regions to a tire tread region, and a pump passageway having an inlet end and an outlet end and being operative to allow a portion of the pump passageway near a tire footprint to close and open the pump passageway. The valve assembly has a valve housing, wherein a diaphragm is mounted in the valve housing forming an interior chamber, and wherein the diaphragm is responsive to a pressure in the tire cavity. The interior chamber has a first hole in fluid communication with the inlet end of the pump passageway, a second hole in fluid communication with the outlet end of the pump passageway, and a third hole in fluid communication with the outside air. The valve housing has a passageway in fluid communication with the tire cavity and the outlet end of the pump passageway. The valve assembly further includes an inlet control valve having a valve bottom positioned over the third hole and operative to open and close the third hole. The inlet control valve has a first end connected to the diaphragm and a resilient member is positioned in the interior chamber of the valve housing, the resilient member biasing the valve bottom into the open position.

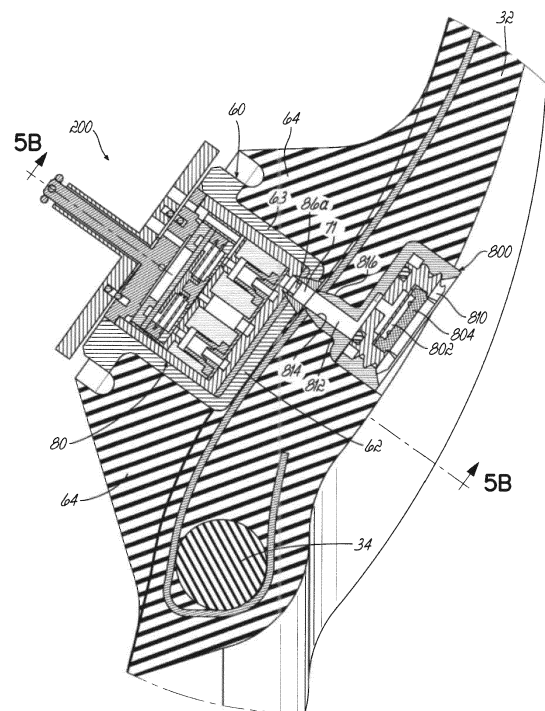

FIG. 5A

EP 2 842 774 A1

Description

Field of the Invention

[0001] The invention relates generally to a tire having a pump and valve assembly such as a self-inflating tire and, more specifically, to a pump mechanism for such tires.

Background of the Invention

[0002] Normal air diffusion reduces tire pressure over time. The natural state of tires is under inflated. Accordingly, drivers must repeatedly act to maintain tire pressures or they will see reduced fuel economy, tire life and reduced vehicle braking and handling performance. Tire Pressure Monitoring Systems have been proposed to warn drivers when tire pressure is significantly low. Such systems, however, remain dependent upon the driver taking remedial action when warned to re-inflate a tire to recommended pressure. It is a desirable, therefore, to incorporate a self-inflating feature within a tire that will self-inflate the tire in order to compensate for any reduction in tire pressure over time without the need for driver intervention.

Summary of the Invention

[0003] The invention relates to a tire in accordance with claim 1, 8 or 9 respectively.

[0004] Dependent claims refer to preferred embodiments of the invention.

[0005] The invention provides in a first preferred aspect a tire having a tire cavity, wherein the tire has a bi-directional pump assembly including a pump passageway having an inlet end and an outlet end, and being operative to allow a portion of the pump passageway near a tire footprint to substantially close and open the pump passageway. The tire includes a valve assembly having a valve housing, wherein a diaphragm is mounted in the valve housing forming an interior chamber, and wherein the diaphragm is responsive to the pressure of the tire cavity. The interior chamber has a first hole in fluid communication with the inlet end of the pump passageway, a second hole in fluid communication with the outlet end of the pump passageway, and a third hole in fluid communication with the outside air. The valve housing has a passageway in fluid communication with the tire cavity and the outlet end of the pump. The valve assembly further includes an inlet control valve having a valve bottom positioned over the third hole and operative to open and close the third hole. The inlet control valve has a first end connected to the diaphragm, and a resilient member biases the inlet control valve into the open position.

[0006] The invention provides is a second preferred aspect a tire having a bidirectional pump and valve assembly. The tire has a tire cavity, and a first and second sidewall extending respectively from first and second tire

bead regions to a tire tread region; said tire having a pump passageway, said pump passageway having a first end and a second end and being operative to allow a portion of the pump passageway near a tire footprint to close and open the pump passageway when the tire is rotated in a first direction or second direction opposite said first direction, the valve assembly having a valve housing, wherein a diaphragm is mounted in the valve housing forming an interior chamber, and wherein the diaphragm is responsive to the pressure of the tire cavity; said interior chamber having a first hole A in fluid communication with a chamber A, a second hole B in fluid communication with the outside air; and a third hole C in fluid communication with a chamber C; said valve assembly further including an inlet control valve positioned in the interior chamber, wherein the inlet control valve is positioned over the second hole and operative to open and close the second hole to allow outside air to enter; wherein a resilient member is positioned in the interior chamber of the valve housing, and being connected to the inlet control valve, wherein the resilient member biases the inlet control valve into the open position; Wherein said chamber A has a one way valve positioned therein, and said chamber A is in fluid communication with the pump passageway first end and the interior chamber, Wherein said chamber C has a one way valve positioned therein, and said chamber C is in fluid communication with the pump passageway second end and the interior chamber; Wherein the valve housing has a chamber D, wherein said chamber D is in fluid communication with the tire cavity and a pump passageway first end, and said chamber D has a one way valve positioned therein; Wherein the valve housing has a chamber E, wherein said chamber E is in fluid communication with the pump passageway first end and the tire cavity, wherein a one way valve is positioned in chamber E.

[0007] The invention provides is a second preferred aspect a tire having a bidirectional pump and valve assembly, the tire comprising a tire cavity and a first and second sidewall extending respectively from first and second tire bead regions to a tire tread region; a pump passageway, the pump passageway having a first end and a second end and being operative to allow a portion of the pump passageway near a tire footprint to close and open the pump passageway when the tire is rotated in a first direction or second direction opposite said first direction; wherein the valve assembly has a valve housing, the valve housing having a first port in fluid communication with a first end of a pump passageway, and a second port in fluid communication with a second end of a pump passageway; wherein a diaphragm is mounted in the valve housing forming an interior chamber and wherein the diaphragm is responsive to a pressure in the tire cavity; wherein the valve housing further includes a chamber A, wherein the chamber A has a one way valve positioned therein, the chamber A having an inlet in fluid communication with the interior chamber, and an outlet in fluid communication with the first port; wherein the

valve housing further includes a chamber B, wherein the chamber B has an inlet and an outlet, wherein the outlet is in fluid communication with the air outside the tire; wherein the valve housing further includes a chamber C, wherein the chamber C has a one way valve positioned therein, and wherein the chamber C has an inlet in fluid communication with the interior chamber and an outlet in fluid communication with the second port; wherein the valve assembly further includes an inlet control valve positioned in the interior chamber, wherein the inlet control valve is positioned over the inlet of the chamber B and operative to open and close the inlet to allow outside air to enter the interior chamber; wherein a resilient member is positioned in the interior chamber of the valve housing and is connected to the inlet control valve, wherein the resilient member biases the inlet control valve into the open position; wherein the valve housing further includes a chamber D and a chamber E; wherein the chamber D has a one way valve positioned therein and has an outlet in fluid communication with the tire cavity and an inlet in fluid communication with pump passageway second end; and wherein a one way valve is positioned in chamber E, the chamber E having an inlet end in fluid communication with the pump passageway first end and a second end in fluid communication with the tire cavity.

[0008] In a preferred aspect of the invention, the resilient member has an inner hub and a plurality of spokes which extend radially from the hub. Preferably, the inner hub is connected to the inlet control valve or the valve bottom.

[0009] In a preferred aspect of the invention, a one way valve is positioned between the first hole and the inlet end of the pump passageway.

[0010] In a preferred aspect of the invention, a one way valve is positioned between the outlet end of the pump passageway and the passageway in the valve housing.

[0011] In a preferred aspect of the invention, a filter assembly is in fluid communication with the outside air.

[0012] In a preferred aspect of the invention, the inlet control valve further includes a second resilient member.

[0013] In a preferred aspect of the invention, the resilient member and/or the second resilient member is made of metal.

[0014] In a preferred aspect of the invention, the tire comprises a bidirectional pump and valve assembly.

[0015] In a preferred aspect of the invention, the inlet control valve is connected to the diaphragm.

[0016] In a preferred aspect of the invention, at least one of the following or any combination or all of the following is held true: the one way valve of chamber A prevents flow from entering the interior chamber; the one way valve of chamber C prevents flow from entering the interior chamber; the one way valve of chamber D prevents flow from the tire cavity from entering the pump passageway; the one way valve of chamber E prevents flow from the tire cavity from entering the pump passageway.

[0017] In a preferred aspect of the invention, a filter is

positioned between the outside air and the second hole.

[0018] In a preferred aspect of the invention, a filter is positioned between the outside air and the third hole.

[0019] In a preferred aspect of the invention, the valve housing has a channel which routes flow from the pump passageway second end to chamber D.

[0020] In a preferred aspect of the invention, the valve housing has a channel which routes flow from the pump passageway first end to the tire cavity.

[0021] In a preferred aspect of the invention, the valve housing has a channel which routes flow from the outlet of chamber E to the tire cavity.

Definitions

[0022] "Aspect ratio" of the tire means the ratio of its section height (SH) to its section width (SW) multiplied by 100 percent for expression as a percentage.

[0023] "Axial" and "axially" means lines or directions that are parallel to the axis of rotation of the tire.

[0024] "Chafer" is a narrow strip of material placed around the outside of a tire bead to protect the cord plies from wearing and cutting against the rim and distribute the flexing above the rim.

[0025] "Circumferential" means lines or directions extending along the perimeter of the surface of the annular tread perpendicular to the axial direction.

[0026] "Equatorial Centerplane (CP)" means the plane perpendicular to the tire's axis of rotation and passing through the center of the tread.

[0027] "Footprint" means the contact patch or area of contact of the tire tread with a flat surface at zero speed and under normal load and pressure.

[0028] "Inboard side" means the side of the tire nearest the vehicle when the tire is mounted on a wheel and the wheel is mounted on the vehicle.

[0029] "Lateral" means an axial direction.

[0030] "Lateral edges" means a line tangent to the axially outermost tread contact patch or footprint as measured under normal load and tire inflation, the lines being parallel to the equatorial centerplane.

[0031] "Net contact area" means the total area of ground contacting tread elements between the lateral edges around the entire circumference of the tread divided by the gross area of the entire tread between the lateral edges.

[0032] "Outboard side" means the side of the tire farthest away from the vehicle when the tire is mounted on a wheel and the wheel is mounted on the vehicle.

[0033] "Passageway" means an integrally formed pathway in the tire or a discrete tube inserted in the tire forming the pump.

[0034] "Peristaltic" means operating by means of wave-like contractions that propel contained matter, such as air, along pathways.

[0035] "Radial" and "radially" means directions radially toward or away from the axis of rotation of the tire.

Brief Description of the Drawings

[0036] The invention will be described by way of example and with reference to the accompanying drawings in which:

Figure 1 is a front view of a tire and wheel assembly showing a pump and valve assembly;
 Figure 2 illustrates the tire and wheel assembly of Figure 1 in operation during tire rotation;
 Figure 3 is an enlarged cross-sectional view of the bead area of the tire, including the pump;
 Figure 4 is an enlarged cross-sectional view illustrating the pump being compressed in the tire bead area;
 Figure 5A is a cross sectional view of the bead area shown with the compact valve system and filter assembly of the present invention;
 Figure 5B is an enlarged view of the compact valve system of Fig. 5A, in a direction 5b-5b;
 Figure 6 is a side perspective view of the compact valve system as viewed from inside the tire;
 Figure 7 is a schematic of the compact valve system of the present invention;
 Figure 8 is a side perspective view of the compact valve system, shown with the insert removed;
 Figure 9 is a top view of the retainer;
 Figure 10 is an exploded view of the retainer with the flow control plate;
 Figure 11 is an exploded view of the compact valve system and filter assembly;
 Figure 12 is a cross-sectional side view of the compact valve system, without the insert, in the direction 12-12 of Figure 13;
 Figure 13 is a top view of the compact valve system, without the insert;
 Figure 14 is a cross-sectional side view of Figure 13 in the direction 14-14;
 Figure 15 is a cross-sectional side view of Figure 14 in the direction 15-15;
 Figure 16 is a cross-sectional side view of Figure 14 in the direction 16-16;
 Figure 17 is a cross-sectional view of the inlet control valve in the direction 17-17 of Figure 19;
 Figure 18 is a cross sectional view of the inlet control valve in the direction 18-18 of Figure 19;
 Figure 19 is a top view of the inlet control valve;
 Figure 20 is a section view of the inlet control valve of Figure 17 in the direction 20-20;
 Figure 21 is an exploded view of the flow controller; and
 Figure 22 is an exploded view of the inlet control valve.

Detailed Description of Example Embodiments the Invention

[0037] Referring to FIGS. 1 and 3, a tire assembly 10 includes a tire 12, a peristaltic pump assembly 14 and is

mounted to a tire wheel 16. The tire mounts in a conventional fashion to a rim having rim mounting surfaces 18 located adjacent outer rim flanges 22. The outer rim flange 22 has an outer rim surface 26. An annular rim body 28 joins the rim flanges 22 and supports the tire assembly as shown. The tire is of conventional construction, having a pair of sidewalls 32 extending from opposite bead areas 34 to a crown or tire tread region 38. The tire and rim enclose an interior tire cavity 40.

[0038] As shown in FIG. 1 the pump assembly 14 includes a pump passageway 42 that is mounted or located in the sidewall area of the tire, preferably near the bead region. The pump passageway 42 may be formed of a discrete tube made of a resilient, flexible material such as plastic, elastomer or rubber compounds, and is capable of withstanding repeated deformation cycles when the tube is deformed into a flattened condition subject to external force and, upon removal of such force, returns to an original condition. The tube is of a diameter sufficient to operatively pass a volume of air sufficient for the purposes described herein and allowing a positioning of the tube in an operable location within the tire assembly as will be described. Preferably, the tube has an elliptical cross-sectional shape, although other shapes such as round may be utilized.

[0039] The pump passageway itself may also be integrally formed into the sidewall of the tire during vulcanization, eliminating the need for an inserted tube. An integrally formed pump passageway is preferably made by building into a selected green tire component such as a chafer, a removable strip made of wire or silicone. The component is built into the tire and cured. The removable strip is then removed post cure to form a molded in or integrally formed pump air passageway.

[0040] Hereinafter, the term " pump passageway" refers either to discrete installed tubes or an integrally molded in pump passageway. The location selected for the air passageway within the tire may be within a tire component residing within a high flex region of the tire, sufficient to progressively collapse the internal hollow air passageway as the tire rotates under load thereby conveying air along the air passageway from the inlet to the pump outlet.

[0041] The pump passageway 42 has an inlet end 42a and an outlet end 42b joined together by a compact valve system 200. As shown, the inlet end 42a and the outlet end 42b are spaced apart approximately 360 degrees forming an annular pump assembly. The invention is not limited to an annular 360 degree pump, and may be non-annular (ie, less than 360 degrees.)

Compact Valve System 200

[0042] A first embodiment of a compact valve system 200 is shown in Figures 5-19. The compact valve system includes an inlet control valve 400 which functions to regulate and control the inlet flow and exit flow of the pump 42. Figure 11 illustrates an exploded view of the compact

valve system 200. Starting from the bottom of the Figure, the compact valve system 200 includes an optional insert 60, a retainer 80, a flow controller 300, an inlet control valve 400 and cap 500, a spring 600, and a lid 700. An optional filter assembly 800 is connected to the compact valve system 200.

Insert 60

[0043] As shown in Figure 10, the compact valve system includes an optional insert 60 that is inserted into a receptacle 64 built in the tire. The receptacle 64 is a raised area or hump formed on the tire inner surface and may optionally include a threaded inner hole, wherein the hump may be built into the tire sidewall using a series of concentric layers of material, such as uncured elastomer, green rubber. A one piece molded shape of rubber or elastomer may also be used instead of the concentric layers. Alternatively, the insert 60 may be inserted into the receptacle prior to vulcanization. The outer insert may be made of green rubber, elastomer, nylon, ultra high molecular weight polyethylene or metal such as brass. The insert is preferably coated with a suitable adhesive such as resorcinol formaldehyde latex (RFL) or commonly referred to as "dip" known to those skilled in the art. The outer surface of the insert may be roughened and coated with the selected RFL. The outer surface of the insert may further include ridges, flanges, extensions, threads or other mechanical means in addition to the selected RFL to retain the insert into the rubber of the tire sidewall.

[0044] As shown in Fig. 5B, the optional insert 60 is shaped like a cup and has an interior section formed by an open end facing the tire cavity, a bottom wall 62 opposite the open end and a sidewall 63. The bottom wall has two male portions 65 and 67 extending from the bottom wall that align and connect to the pump passageways 42a, 42b for communicating fluid between the insert 60 and pump 42. Each male portion has a hole therethrough for communicating filtered air to the interior of the valve. The bottom portion also has two opposed holes 68, 69 for alignment and fluid communication with the pump passageways 42a, 42b. An optional gasket 70 is positioned on the bottom wall 62 of the insert 60. The gasket is circular and flat, with holes aligned with the holes 68, 69 of the insert 60. The gasket may also have protruding rims around the three holes. As shown in Figure 5A, the bottom wall 62 of the insert 60 has a third hole 71 for receiving the male portion 820 of the filter assembly 800. The outer insert 60 also has a flanged rim portion 61 that surrounds the sidewall 63 with opposed female slots. A lid 700 with two opposed U shaped connectors 710 are received within opposed female slots.

Retainer 80

[0045] The optional outer insert 60 houses a retainer 80. The retainer 80 is shown in Figures 5A, 5B, and FIGS.

8-10. The retainer 80 is generally cylindrically shaped, with an alignment key 82 projecting from the outer surface. The alignment key 82 is seated in mating engagement with an alignment slot (not shown) formed in the sidewall of the outer insert 60. The alignment key 82 ensure that slots 83a, 84a on the bottom surface 85 of the valve body aligns with holes 68, 69 of the insert. The bottom surface 85 of the insert further includes a hole 86 for receiving filtered air from the filter assembly 800. The insert 60 is an optional component that may be eliminated, and the outer surface of the insert 80 may be threaded for reception into the receptacle 64.

[0046] Figure 9 illustrates a view from the top of the retainer 80 looking down inside the retainer. The bottom surface 81 of the retainer has grooved passageways 83b, 86b, and 84b formed therein. As shown in Figure 10 an upper plate 87 is positioned over the bottom surface 81, so that an alignment tab 91 is received in the alignment key 82 of the retainer 80. The grooved passageways 83b, 86b, and 84b cooperate with the upper plate 87 to channel the flow through the passageways from 83a, 84a, 86a to 83c, 84c, 86c, respectively. Slotted holes 83a, 84a communicate fluid from the pump 42 to the compact valve system 200. Fluid from the pump enters slotted holes 83a, 84a and then are communicated through angled channels 83b, 84b to port the fluid from the slotted holes 83a, 84a to locations 83c, 84c. Flow from locations 83c, 84c are then directed through port 89, 90 of upper plate 87. The upper plate 87 has opposed slots 92, 93 positioned for alignment with slots 83a, 84a. Inlet flow from the filter enters the retainer through hole 86a, and then through angled channel 86b into location 86c. Flow from location 86c is then routed to central hole 88 of the upper plate 87.

[0047] A flow controller 300 is positioned inside the retainer 80. As shown in Fig. 21, the flow control body 302 has an alignment tab 304 positioned for reception in the alignment key 82 of the retainer. The flow controller 300 has directional control valves 306, 308 and anti return or check valves 310, 312 as shown in Figure 21.

[0048] Figure 7 illustrates a schematic of the tire assembly 10 including the flow controller 300 and its relation to the pump 42 and inlet control valve 400. The inlet control valve 400 controls whether outside filtered air is permitted to enter the system. If air is needed, the inlet control valve 400 opens and allows air to enter the pump. The flow controller 300 has directional control valves 306, 308 that are received in respective chambers 307, 309. The flow controller further includes two anti return or check valves 310, 312 mounted in chambers 311, 313. The flow controller has a central port 315 that communicates flow from the inlet 86c through the flow controller and into communication with the inlet control valve 400. As shown in Figure 7, air from outside the tire enters the filter assembly 800 and enters inlet control valve 400. If the tire needs air as determined by the inlet control valve 400, air enters the system through the inlet control valve 400, and then depending on the direction of the tire rotation,

enters through a directional valve 306, then through the pump and then exits through anti return valve 310 and then into the tire. If the tire is rotating in the opposite direction, air enters through directional valve 308, is directed into the pump and then into anti return valve 312 and then into tire. Anti return valves 310, 312 prevent backflow of air from the tire cavity 40 into the pump 42.

Inlet Control Valve 400

[0049] As shown in Figure 11, an inlet control valve 400 is positioned inside the retainer 80 and adjacent to the flow controller 300. The inlet control valve 400 regulates the intake flow to the pump system. As shown in Figures 17-18, the inlet control valve has a housing 402 for housing a circular shaped diaphragm 404. In a first direction, the housing 402 has three aligned holes on the bottom surface: a central hole 415 and first and second passageways 426, 428. The housing also has three aligned holes on the bottom surface in a second direction, perpendicular to the first direction: third passageway 430, central hole 415 and fourth passageway 432.

[0050] A bottom plate 418 is positioned on the bottom of the inlet control valve housing 402. The bottom plate 418 has a central hole 420 for alignment with a valve bottom 414 and a central hole 415 of valve housing. As shown in Figure 17, the bottom plate 418 has two holes 422, 424 which align with external passageways 426, 428 of the inlet control valve housing 402. Each external passageway 426, 428 aligns with chamber 307, 309 respectively of the flow controller 300. As shown in Figure 18, the bottom plate 418 blocks flow from passageways 430, 432 into the inlet control valve housing. Flow from passageway 430 is routed via curved slot 450 formed in the inlet control housing. The curved slot 450 routs flow from passageway 430 to channel 460 and then through outlet channel 470.

[0051] As shown in Figures 17-20, an inlet control valve body 410 is formed of the valve bottom 414, an optional spacer 416 and a valve top 412. The valve top 412 has a circular planar region having a first side positioned adjacent a circular diaphragm 404, and a second side having a central collar 413 extending therefrom. An optional spacer 416 may be received about the collar 413. The valve bottom 414 has a plug 417 which is received in the collar 413. The valve bottom 414 is positioned to be seated within central hole 420 of the bottom plate 418, and positioned to block flow from central hole 415. A first elastic member 471 has an inner hole 472 that is positioned between the spacer 416 and the valve top 412. The first elastic member 471 has a plurality of spokes 474 which extend radially from an annular member 476. The outer ends 478 of the spokes are received between two annular spacers 480, 482. An optional second elastic member 484 may have the outer radial ends received between the annular spacer 480 and the bottom plate 418. The inner portion of the optional second elastic member 484 may be received between the valve bottom and the spac-

er 416. The first and second elastic members 471, 484 are formed of a resilient material such as metal, rubber, elastomer to function as a spring.

[0052] As shown in Figure 14, the inlet control valve further includes a cover 406 having a hole 408 that is positioned over the diaphragm 404. The diaphragm 404 is positioned adjacent valve body 410. An inner cap 500 is positioned over the inlet control valve. The inner cap has an interior hole 502 to allow fluid communication of the diaphragm with the inside cavity of the tire. The cap has a second hole 504 that is in fluid communication with the passageway 470. A lid 700 is received over the inner cap 500. A spring 600 is positioned between the lid 700 and the inner cap 500. The inner cap 500 has a central support column 510 which is received in a central hole 702 of outer cap. The outer cap has aligned holes 704, 706 with holes 502, 504. The lid 700 has two opposed U shaped connectors 710 that are received within opposed female slots of the outer insert 60.

Filter assembly 800

[0053] As shown in Figure 5A, the filter assembly 800 may be mounted on the outside of the tire, preferably in the lower bead area of the sidewall. The filter assembly is shown having a circular cross-sectional shape with a hard plastic exterior that is shown mounted in the lower sidewall area near the bead. The filter assembly 800 has an interior section 802 filled with porous media 804 suitable for filtering air. The filter assembly 800 has an inlet 810 to receive ambient air. Air travels through the inlet 810 and into the interior section 802 where the air is filtered by the porous media 804. The air exits the outlet 812 of the interior section and into passageway 814 that extends through a male fitting 816. The male fitting 816 is received in connector hole 71 of the outer insert and aligned for fluid communication with holes 86 of the retainer and hole 86a of the insert.

Pump Operation

[0054] The compact valve system 200 controls the flow of air into the pump system. As shown in Figures 6 and 14, the tire cavity pressure is communicated to the diaphragm 404 via holes 704, 502, 408. The tire cavity pressure acts on the diaphragm 404 closing and seating the valve bottom against the central hole 415 so that no air can enter into the compact valve system. The first and second resilient member 471, 484 counteracts the tire cavity pressure, acting as a spring to bias the valve bottom in the open position. The resilient members are designed to have a set trigger pressure, so that if the tire cavity pressure falls below the trigger pressure, the resilient member(s) bias the valve bottom away from the central hole 415 into the open position. When central port 315 opens, filtered outside air enters the compact valve system 200 via hole 86a.

[0055] After the air enters the compact valve system

200 via hole 86a, the filtered air is routed through angled channel 86b into central location 86c of the retainer 80 as shown in Figures 9, 16. As shown in Figure 14, flow from central location 86c of the retainer is then routed to central hole 88 and then into central port 315 of the flow controller 300. Air passes through central hole 415 of the inlet control valve and into the inlet control valve interior chamber 403. As shown in Figure 12, the air then passes through bottom plate hole 422, through first passageway 426 and into flow controller 300. The flow passes through directional control valve 306, into chamber 307, and then exits through aligned holes 92, 83a, 68 into pump inlet 42a.

[0056] As will be appreciated from FIG. 2, air pump 42 is shown as a 360 degree pump, with the inlet and outlet co-located. As the tire rotates in a direction 108, a footprint 100 is formed against the ground surface. A compressive force 104 is directed into the tire from the footprint 100 and acts to flatten a segment 110 of the pump 42 as shown at numeral 106. Flattening of the segment 110 of the pump 42 forces a portion of air located between the flattened segment 110 and the compact valve system 200, towards the compact valve system 200. As the tire continues to rotate in direction 108 along the ground surface 98, the pump tube 42 will be sequentially flattened or squeezed segment by segment 110, 110', 110" in a direction opposite to the tire rotation 108. The sequential flattening of the pump tube 42 segment by segment causes the column of air located between the flattened segments to be pumped to the pump outlet 42b.

[0057] The pumped air enters the compact valve system 200 via slot 84a. The check valve 308 blocks flow from entering chamber 309. The pumped air travels from slot 84a through channel 84b to port 84c. The pumped air flows from location 84c is then directed through port 90 of upper plate 87. The pumped air flows through check valve 312 into chamber 313, and then exits the inlet control valve via fourth passageway 432 of inlet control housing 402, through channel 460 connected to outlet 470 of the inlet control valve, and then through aligned holes 504 of inner cap and 706 of lid into the tire cavity. The tire will be pumped with air from the pump and inlet control valve assembly 200 until the tire pressure exceeds the trigger pressure. If the tire pressure exceeds the trigger pressure, the valve bottom will seat over central port 415, and no longer air to enter the system.

[0058] If the direction of the tire rotation is reversed, the pump and inlet control valve system will work as described above except for the following differences. Filtered air will enter the system into the inlet control valve chamber 403 and then enter the pump 42b via check valve 308 into chamber 309 and exit through hole 84a into pump. The pumped air will enter the compact valve system 200 through hole 83a. The check valve 306 will block the flow from entering chamber 307, and force the pumped air through channel 83b into hole 83c as shown in Figure 16. As shown in Figure 14, the pumped air passes through directional valve 310, into chamber 311 and

into passageway 430. Flow from passageway 430 is routed via curved slot 450 formed in the inlet control housing to channel 460 and then through outlet channel 470. The pumped air then exits as described above into the tire cavity.

[0059] As described above, the peristaltic pump assembly may be positioned in the tire sidewall, radially outward of the rim flange surface 26 in the chafer 120. So positioned, the air tube 42 is radially inward from the tire footprint 100 and is thus positioned to be flattened by forces directed from the tire footprint as described above. The segment that is opposite the footprint 100 will flatten from the compressive force 106 from the footprint 100 pressing the tube segment against the rim flange surface 26. Although the positioning of the tube 42 is specifically shown as between a chafer 120 of the tire at the bead region 34 and the rim surface 26, it is not limited to same, and may be located at any region which undergoes compression, such as anywhere in the sidewall or tread.

[0060] From the forgoing, it will be appreciated that the subject invention may be used with a secondary tire pressure monitoring system (TPMS) (not shown) of conventional configuration that serves as a system fault detector. The TPMS may be used to detect any fault in the self-inflation system of the tire assembly and alert the user of such a condition.

Claims

1. A tire having a pump and valve assembly, the tire comprising:

a tire cavity and a first and second sidewall extending respectively from first and second tire bead regions to a tire tread region;

a pump passageway having an inlet end and an outlet end and being operative to allow a portion of the pump passageway near a tire footprint to close and open the pump passageway;

the valve assembly having a valve housing, wherein a diaphragm is mounted in the valve housing forming an interior chamber, and wherein the diaphragm is responsive to a pressure in the tire cavity;

the interior chamber having a first hole in fluid communication with the inlet end of the pump passageway, a second hole in fluid communication with the outlet end of the pump passageway, and a third hole in fluid communication with the outside air;

the valve housing having a passageway in fluid communication with the tire cavity and the outlet end of the pump passageway,

the valve assembly further including an inlet control valve having a valve bottom positioned over the third hole and operative to open and close

- the third hole;
 wherein the inlet control valve has a first end connected to the diaphragm;
 wherein a resilient member is positioned in the interior chamber of the valve housing; and
 wherein the resilient member biases the valve bottom into the open position.
2. The tire of claim 1 wherein the resilient member has an inner hub and a plurality of spokes which extend radially from the hub, and, optionally, wherein the inner hub is connected to the inlet control valve or the valve bottom.
3. The tire of claim 1 or 2 wherein a one way valve is positioned between the first hole and the inlet end of the pump passageway; and/or wherein a one way valve is positioned between the outlet end of the pump passageway and the passageway in the valve housing.
4. The tire of at least one of the previous claims wherein a filter assembly is in fluid communication with the outside air.
5. The tire of at least one of the previous claims wherein the inlet control valve further includes a second resilient member.
6. The tire of at least one of the previous claims wherein the resilient member and/or the second resilient member is made of metal.
7. The tire of at least one of the previous claims wherein the tire comprises a bidirectional pump and valve assembly.
8. A tire having a bidirectional pump and valve assembly, the tire comprising:
 a tire cavity and a first and second sidewall extending respectively from first and second tire bead regions to a tire tread region;
 a pump passageway having a first end and a second end and being operative to allow a portion of the pump passageway near a tire footprint to close and open the pump passageway when the tire is rotated in a first direction or second direction opposite the first direction;
 wherein the valve assembly has a valve housing, wherein a diaphragm is mounted in the valve housing forming an interior chamber, and wherein the diaphragm is responsive to a pressure in the tire cavity;
 wherein the interior chamber has a first hole A in fluid communication with a chamber A, a second hole B in fluid communication with the outside air; and a third hole C in fluid communication
- with a chamber C;
 wherein the valve assembly further includes an inlet control valve positioned in the interior chamber, wherein the inlet control valve is positioned over the second hole B and operative to open and close the second hole B to allow outside air to enter;
 wherein a resilient member is positioned in the interior chamber of the valve housing and biases the inlet control valve into the open position;
 wherein the chamber A has a one way valve positioned therein, and the said chamber A is in fluid communication with the pump passageway first end and the interior chamber,
 wherein the chamber C has a one way valve positioned therein, and the chamber C is in fluid communication with the pump passageway second end and the interior chamber;
 wherein the valve housing has a chamber D, wherein the chamber D is in fluid communication with the tire cavity and a pump passageway first end, and said chamber D has a one way valve positioned therein; and
 wherein the valve housing has a chamber E, wherein the chamber E is in fluid communication with the pump passageway second end and the tire cavity, wherein a one way valve is positioned in chamber E.
9. A tire having a bidirectional pump and valve assembly, the tire comprising:
 a tire cavity and a first and second sidewall extending respectively from first and second tire bead regions to a tire tread region;
 a pump passageway, the pump passageway having a first end and a second end and being operative to allow a portion of the pump passageway near a tire footprint to close and open the pump passageway when the tire is rotated in a first direction or second direction opposite said first direction;
 wherein the valve assembly has a valve housing, the valve housing having a first port in fluid communication with a first end of a pump passageway, and a second port in fluid communication with a second end of a pump passageway;
 wherein a diaphragm is mounted in the valve housing forming an interior chamber and wherein the diaphragm is responsive to a pressure in the tire cavity;
 wherein the valve housing further includes a chamber A, wherein the chamber A has a one way valve positioned therein, the chamber A having an inlet in fluid communication with the interior chamber, and an outlet in fluid communication with the first port;

wherein the valve housing further includes a chamber B, wherein the chamber B has an inlet and an outlet, wherein the outlet is in fluid communication with the air outside the tire;
 wherein the valve housing further includes a chamber C, wherein the chamber C has a one way valve positioned therein, and wherein the chamber C has an inlet in fluid communication with the interior chamber and an outlet in fluid communication with the second port;
 wherein the valve assembly further includes an inlet control valve positioned in the interior chamber, wherein the inlet control valve is positioned over the inlet of the chamber B and operative to open and close the inlet to allow outside air to enter the interior chamber;
 wherein a resilient member is positioned in the interior chamber of the valve housing and is connected to the inlet control valve, wherein the resilient member biases the inlet control valve into the open position;
 wherein the valve housing further includes a chamber D and a chamber E;
 wherein the chamber D has a one way valve positioned therein and has an outlet in fluid communication with the tire cavity and an inlet in fluid communication with pump passageway second end; and
 wherein a one way valve is positioned in chamber E, the chamber E having an inlet end in fluid communication with the pump passageway first end and a second end in fluid communication with the tire cavity.

10. The tire of claim 1, 8 or 9 wherein the inlet control valve is connected to the diaphragm.

11. The tire of claim 8 or 9 wherein at least one of the following is held true:

- (i) the one way valve of chamber A prevents flow from entering the interior chamber;
- (ii) the one way valve of chamber C prevents flow from entering the interior chamber;
- (iii) the one way valve of chamber D prevents flow from the tire cavity from entering the pump passageway;
- (iv) the one way valve of chamber E prevents flow from the tire cavity from entering the pump passageway.

12. The tire of claim 8 wherein a filter is positioned between the outside air and the second hole.

13. The tire of claim 1 or 9 wherein a filter is positioned between the outside air and the third hole.

14. The tire of at least one of the previous claims 8 to 13

wherein the valve housing has a channel which routes flow from the pump passageway second end to chamber D; and/or wherein the valve housing has a channel which routes flow from the pump passageway first end to the tire cavity.

15. The tire of at least one of the previous claims 8 to 14 wherein the valve housing has a channel which routes flow from the outlet of chamber E to the tire cavity.

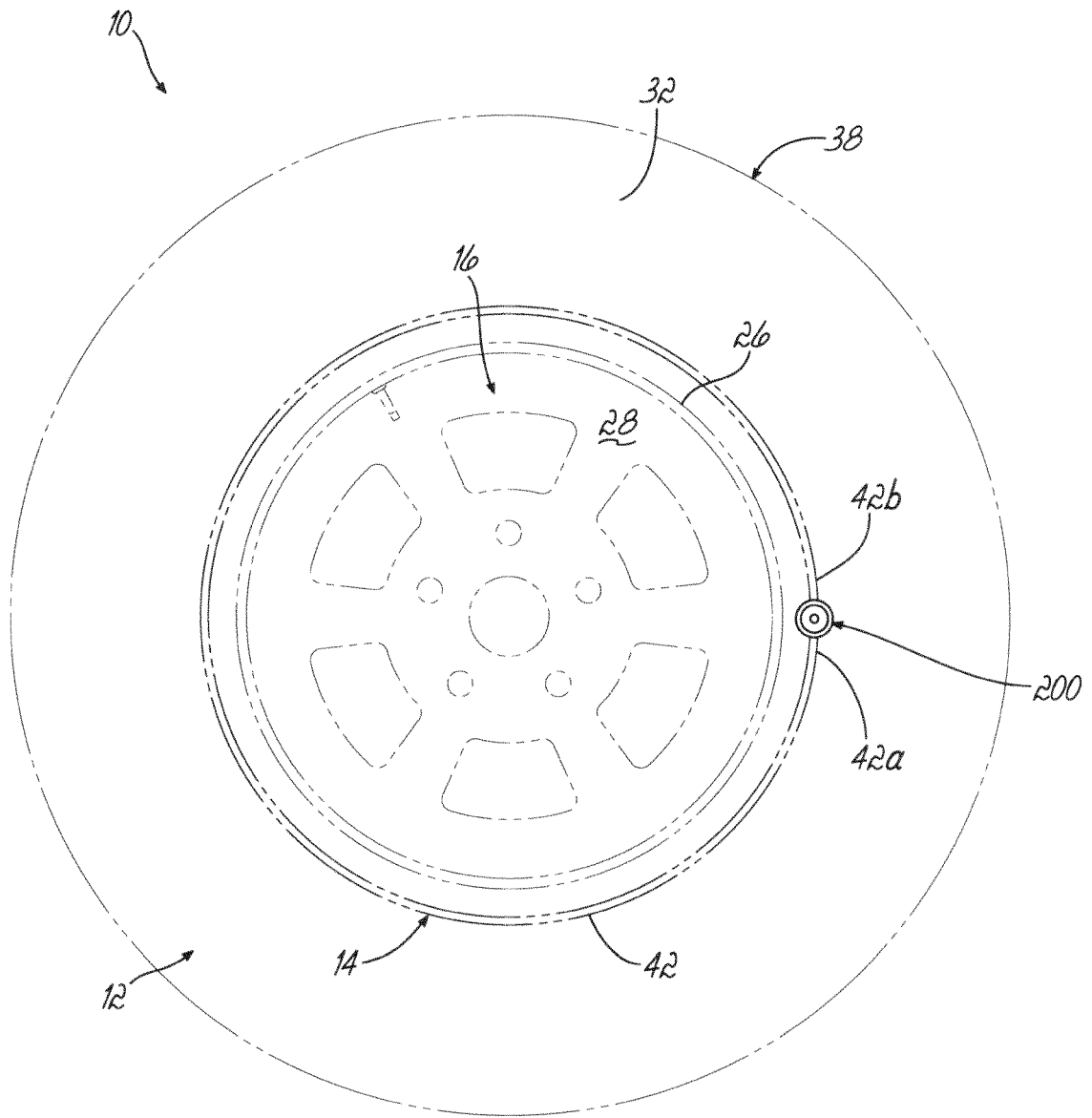

FIG. 1

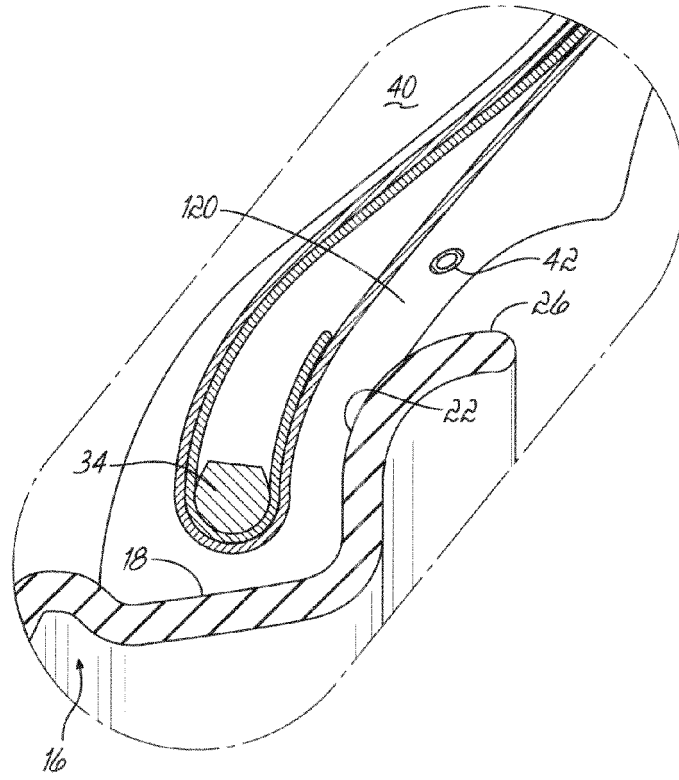

FIG. 3

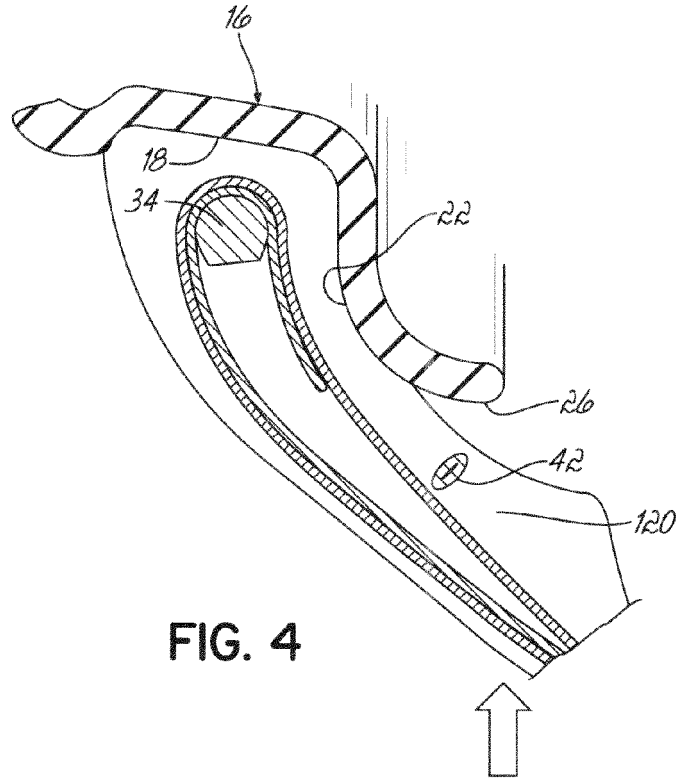

FIG. 4

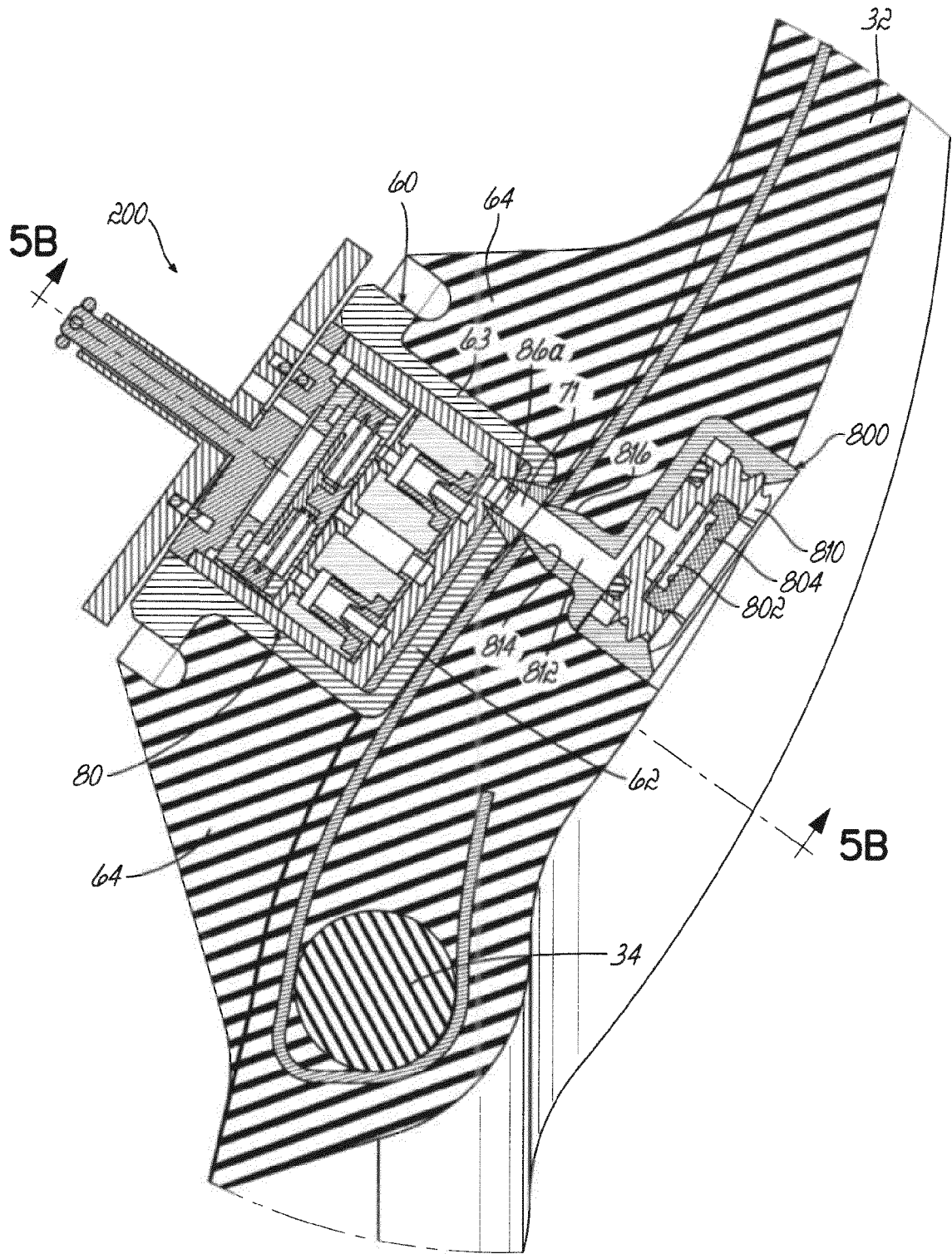

FIG. 5A

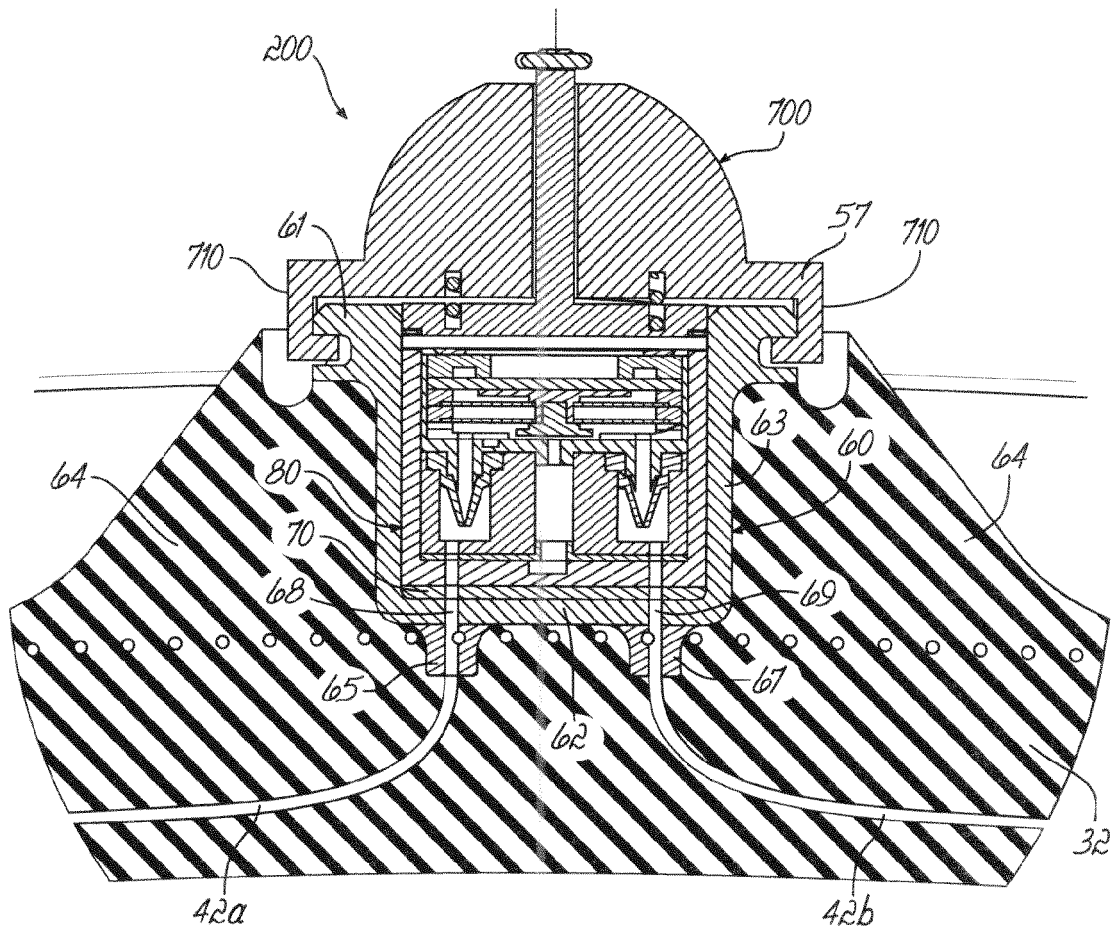

FIG. 5B

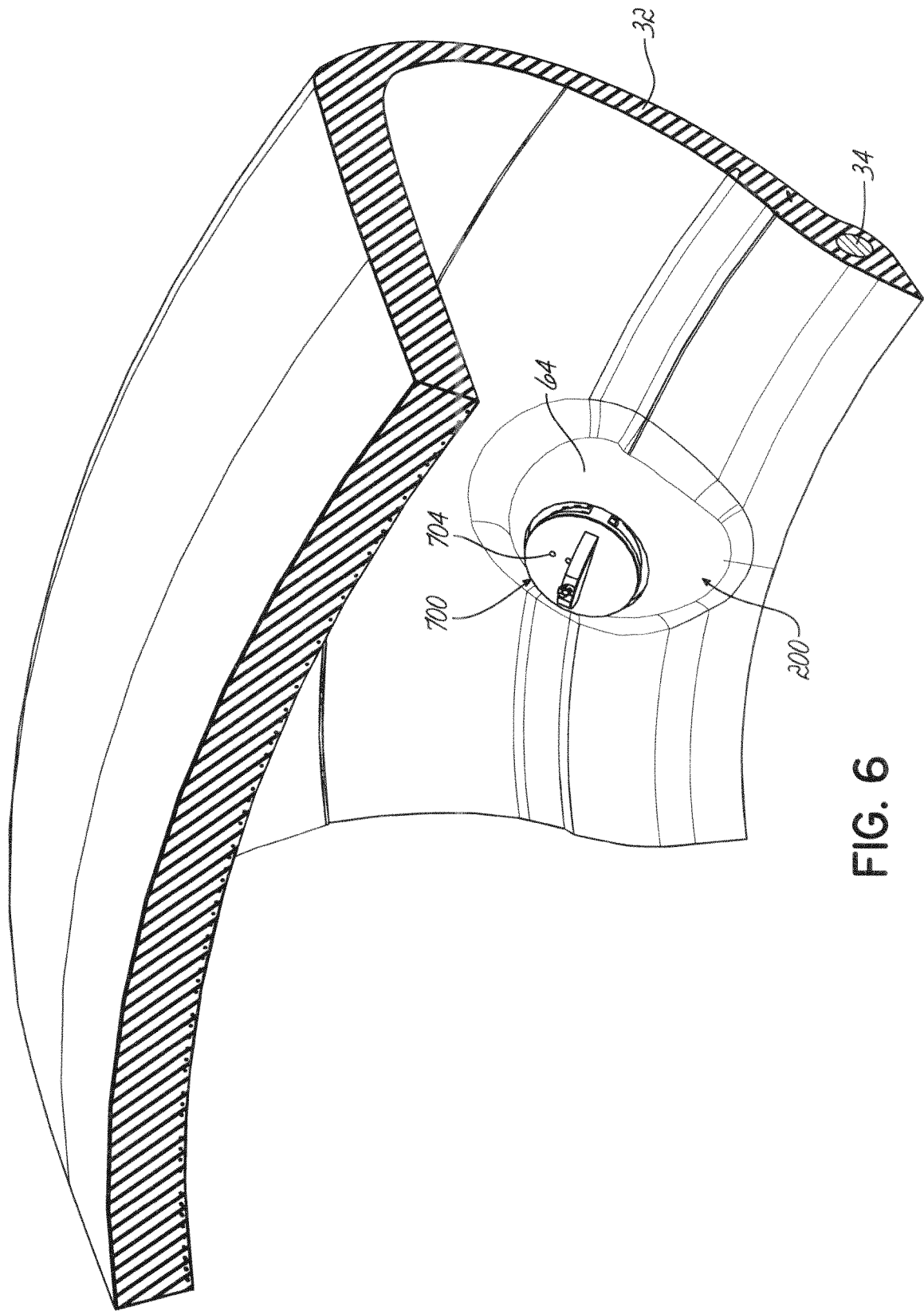

FIG. 6

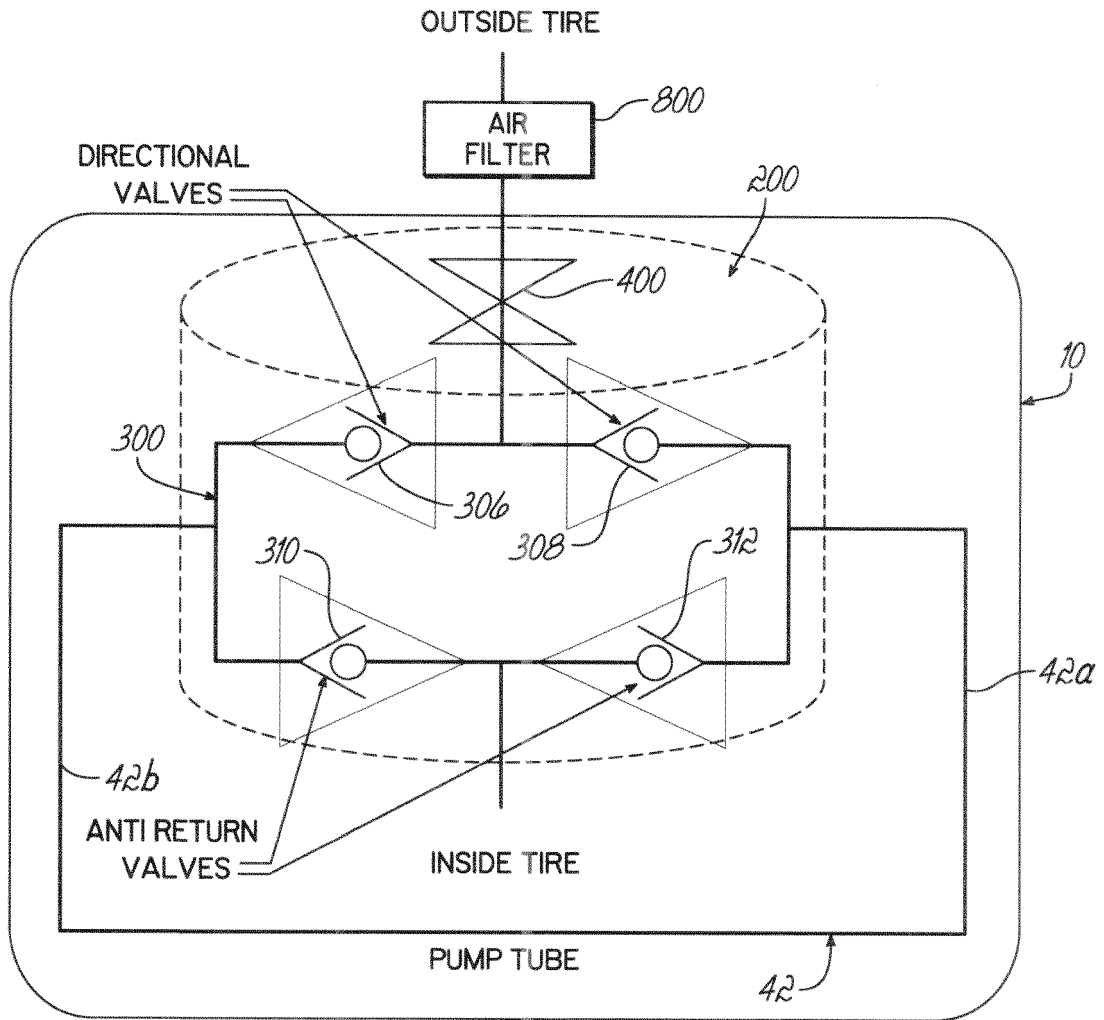

FIG. 7

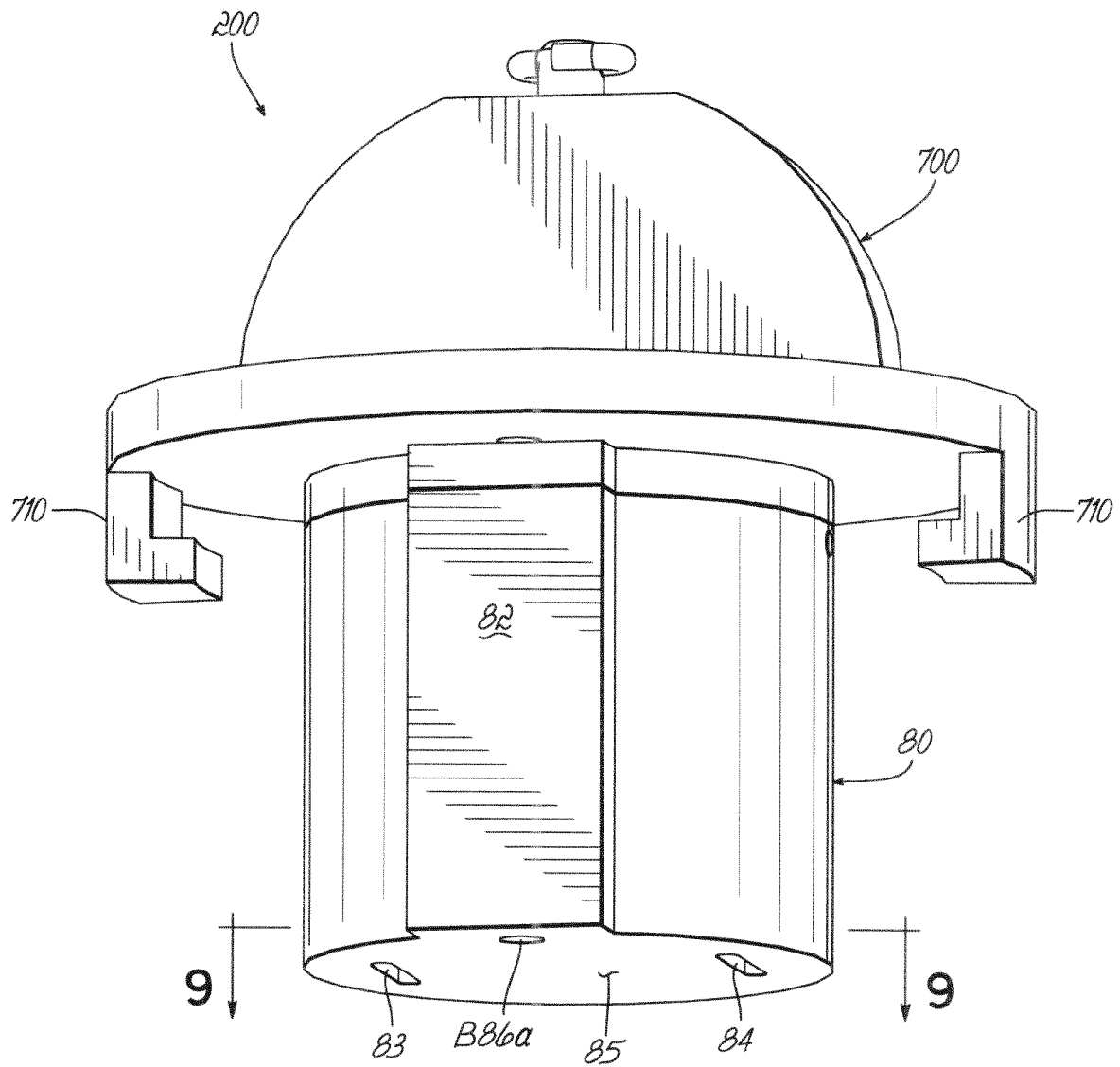

FIG. 8

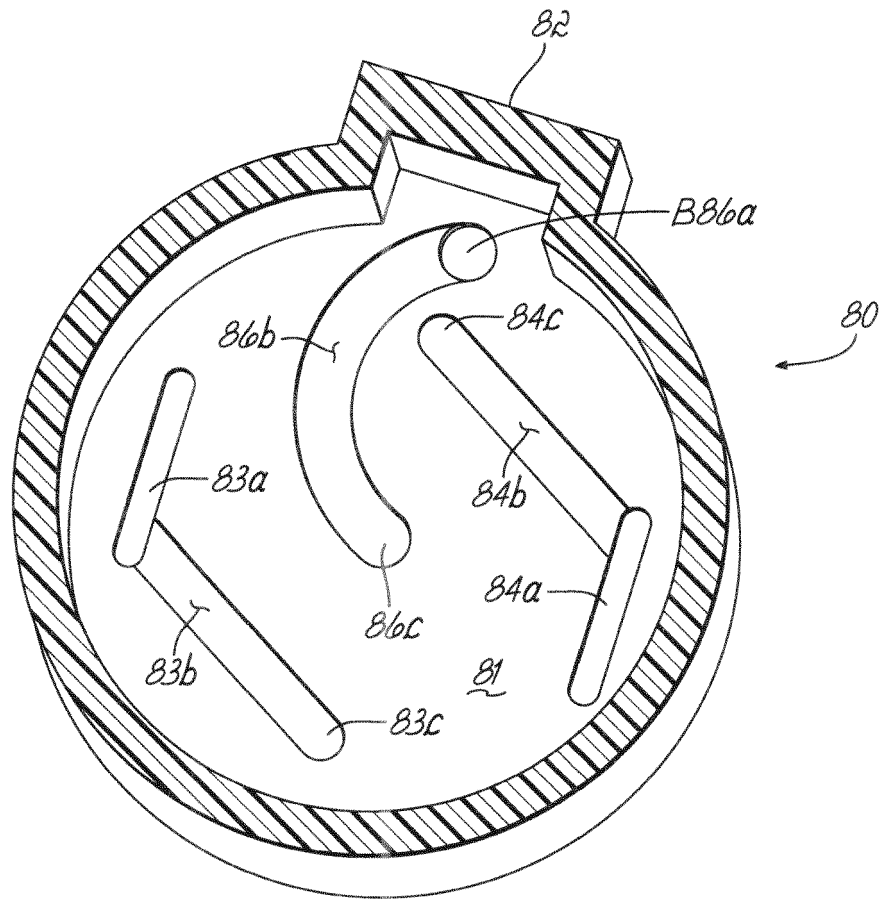

FIG. 9

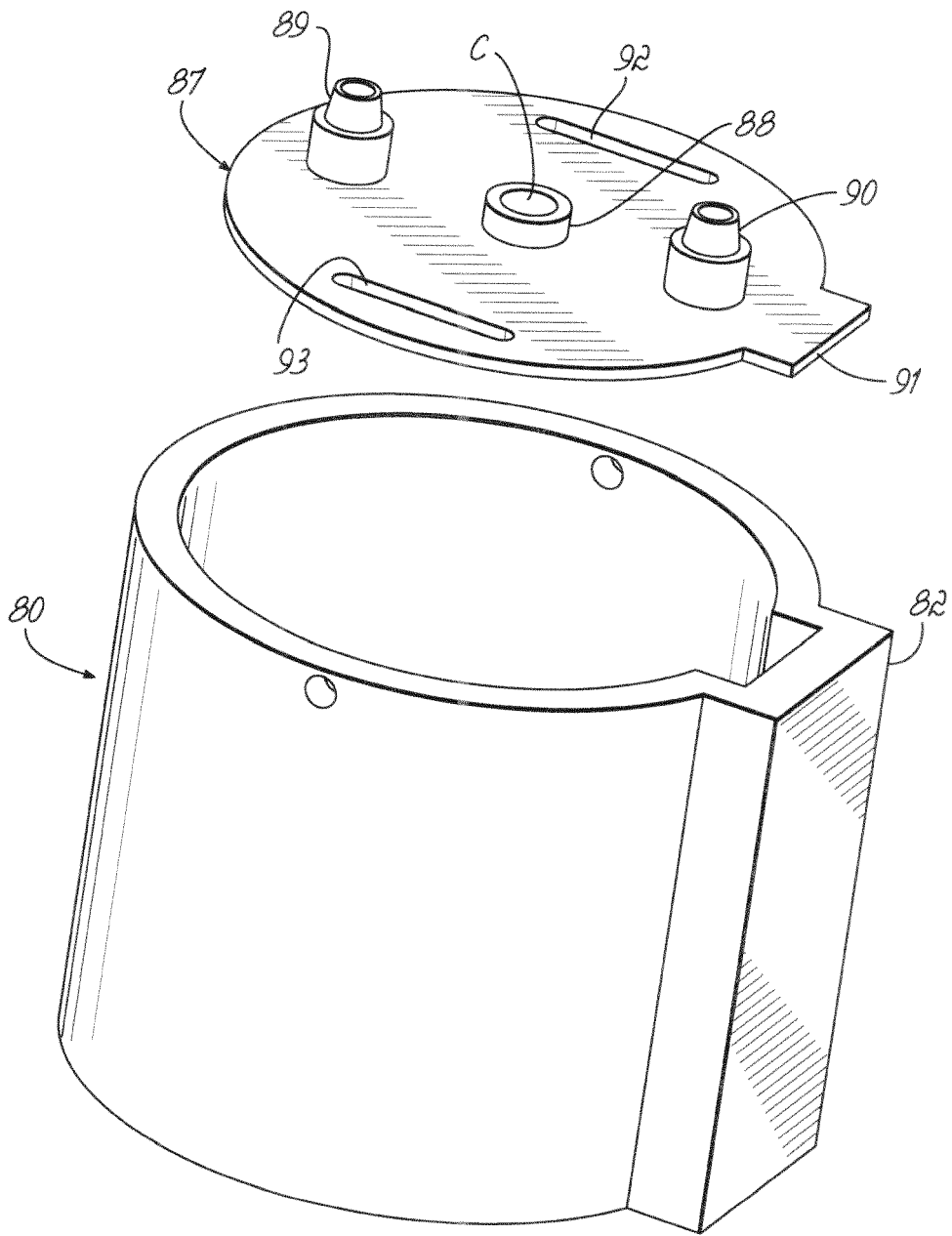

FIG. 10

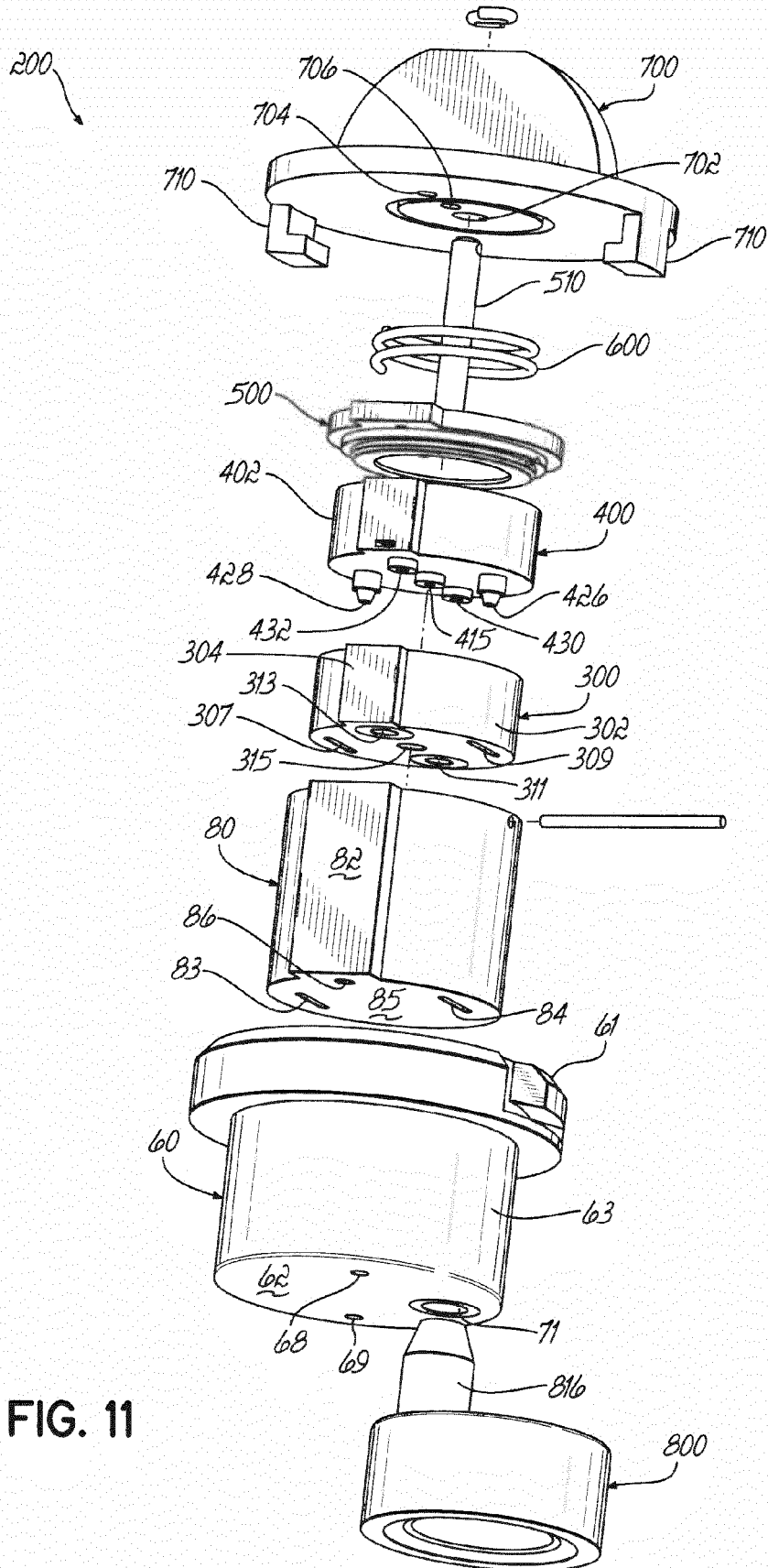

FIG. 11

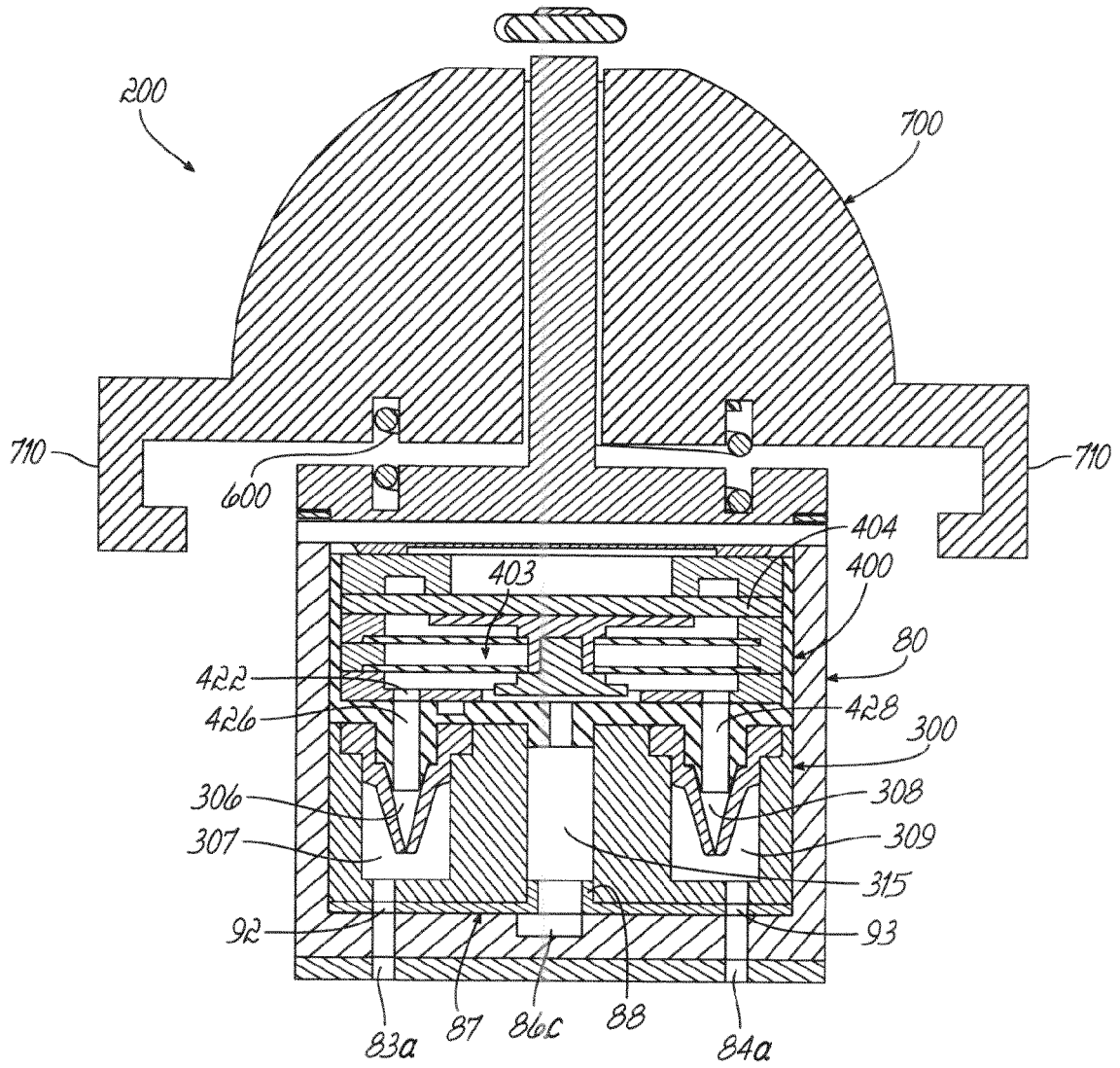

FIG. 12

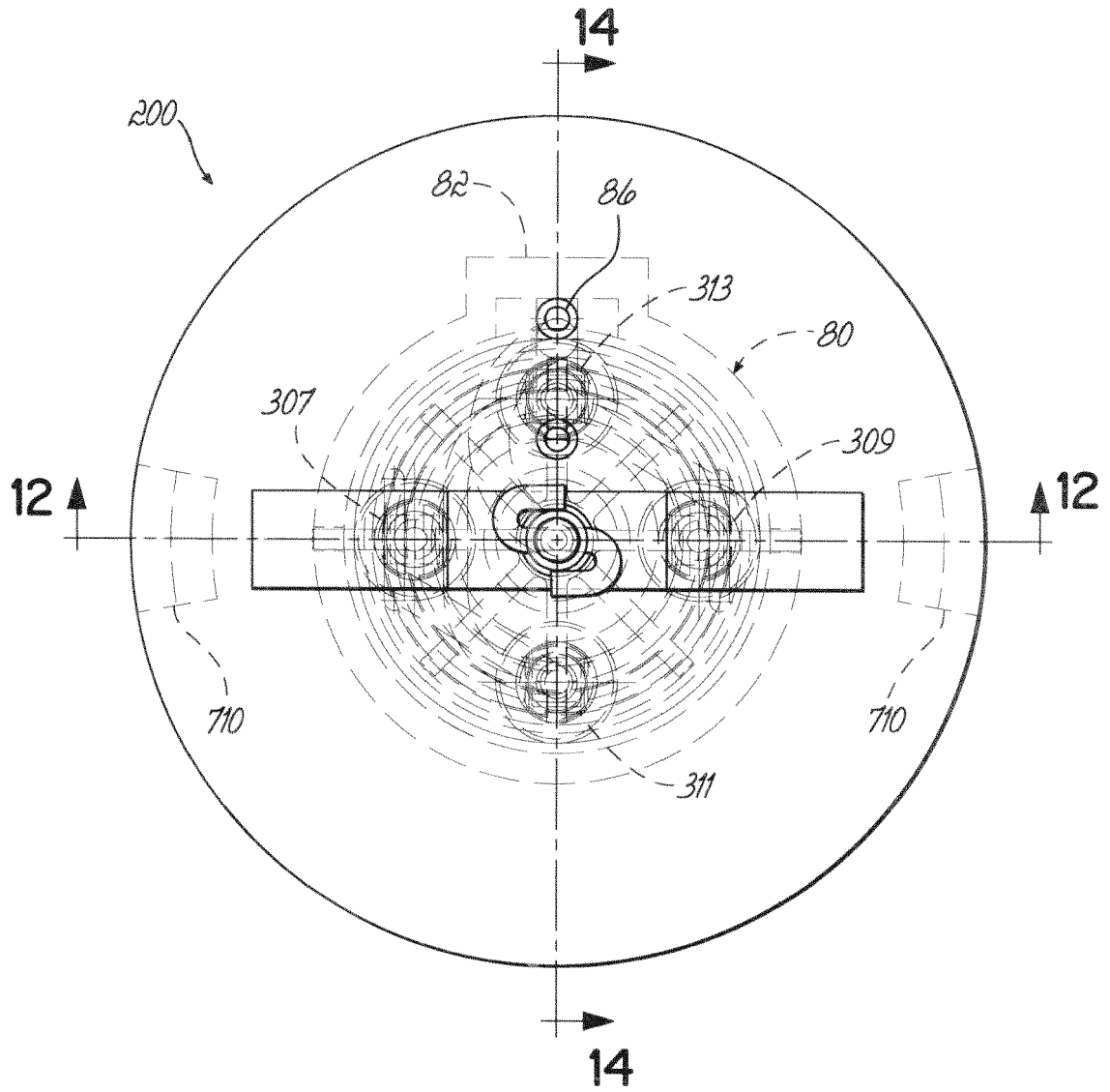

FIG. 13

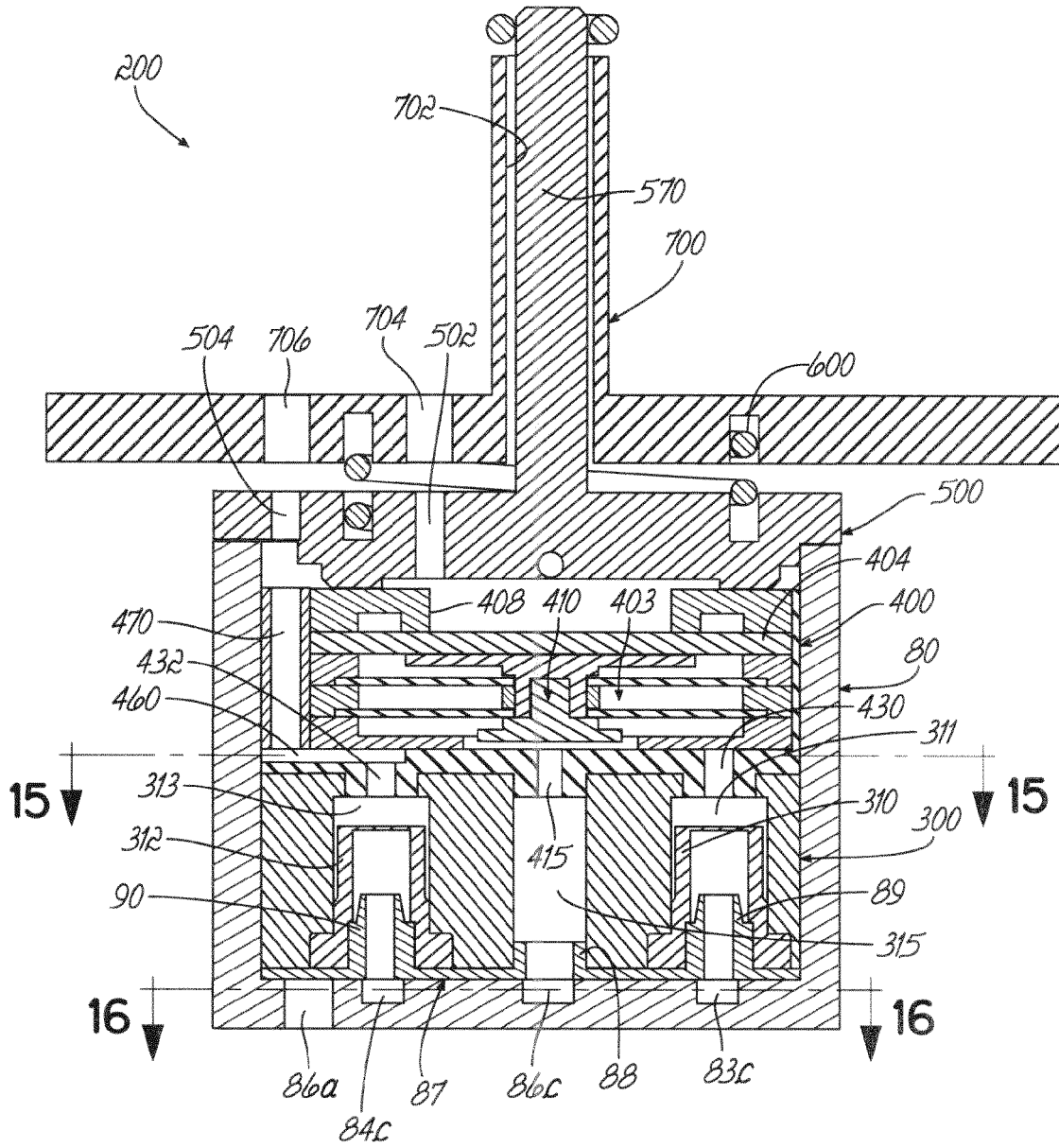

FIG. 14

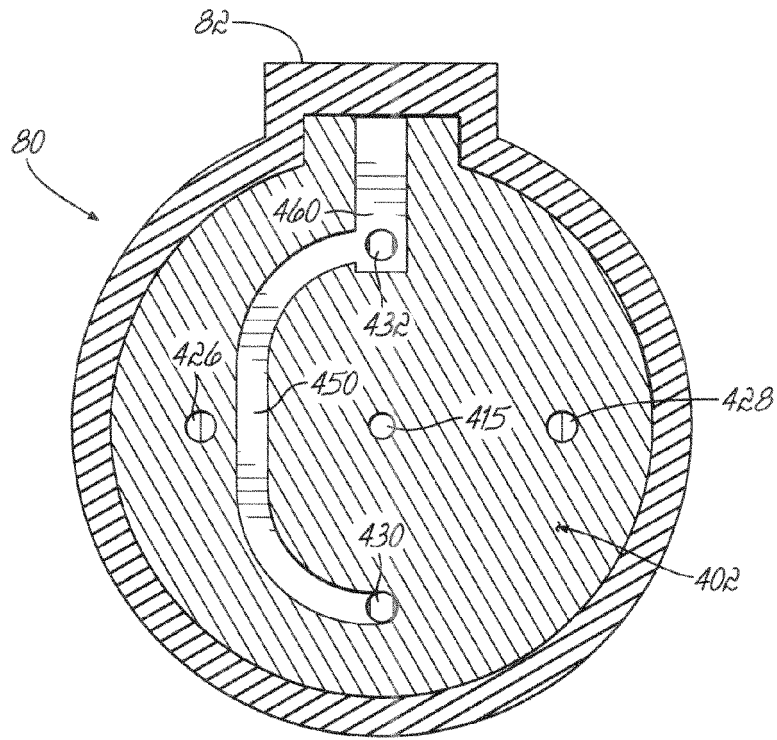

FIG. 15

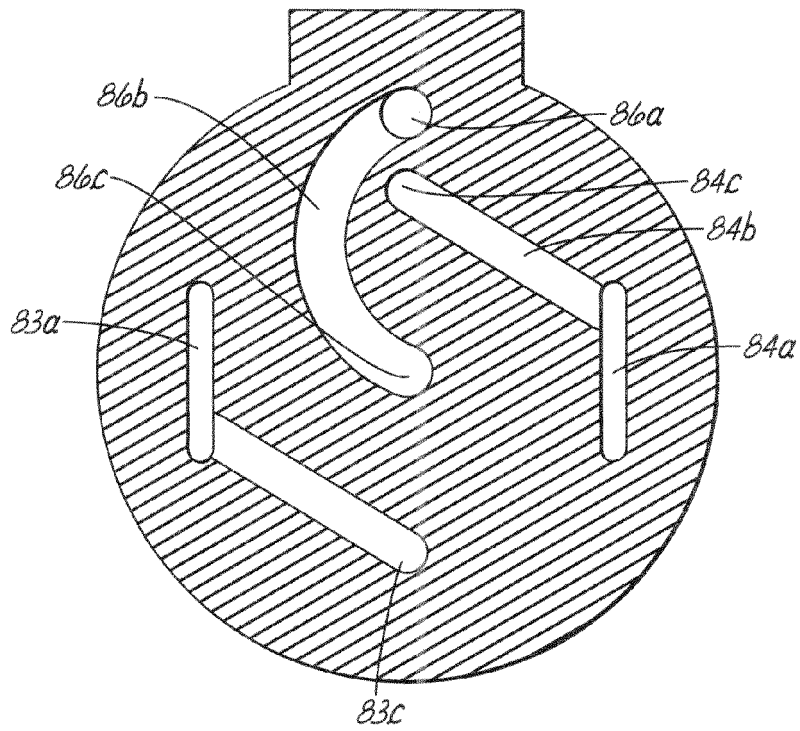

FIG. 16

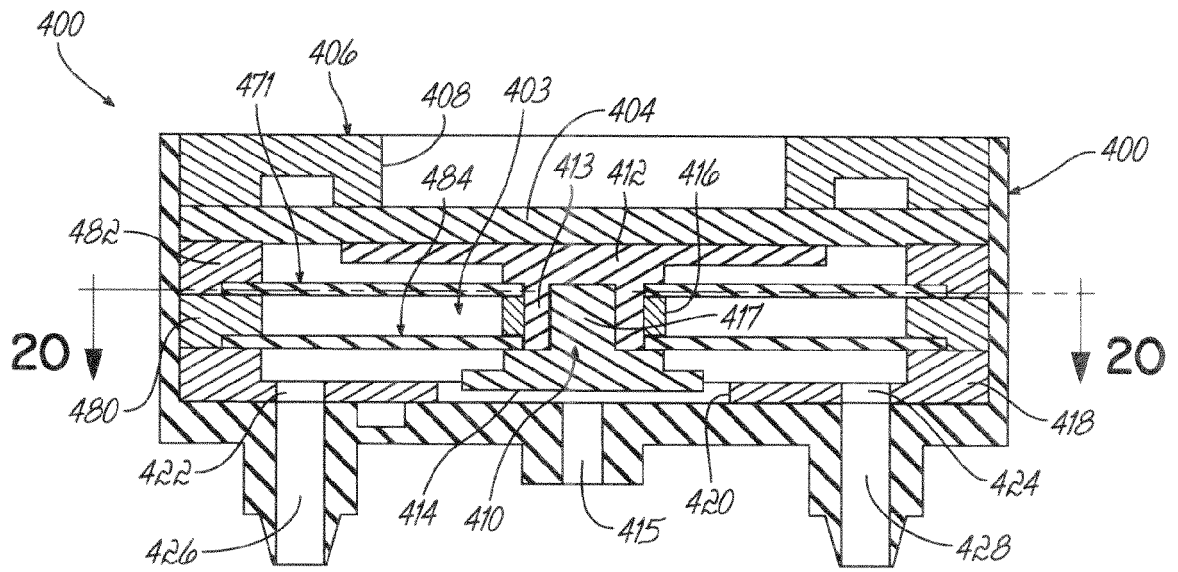

FIG. 17

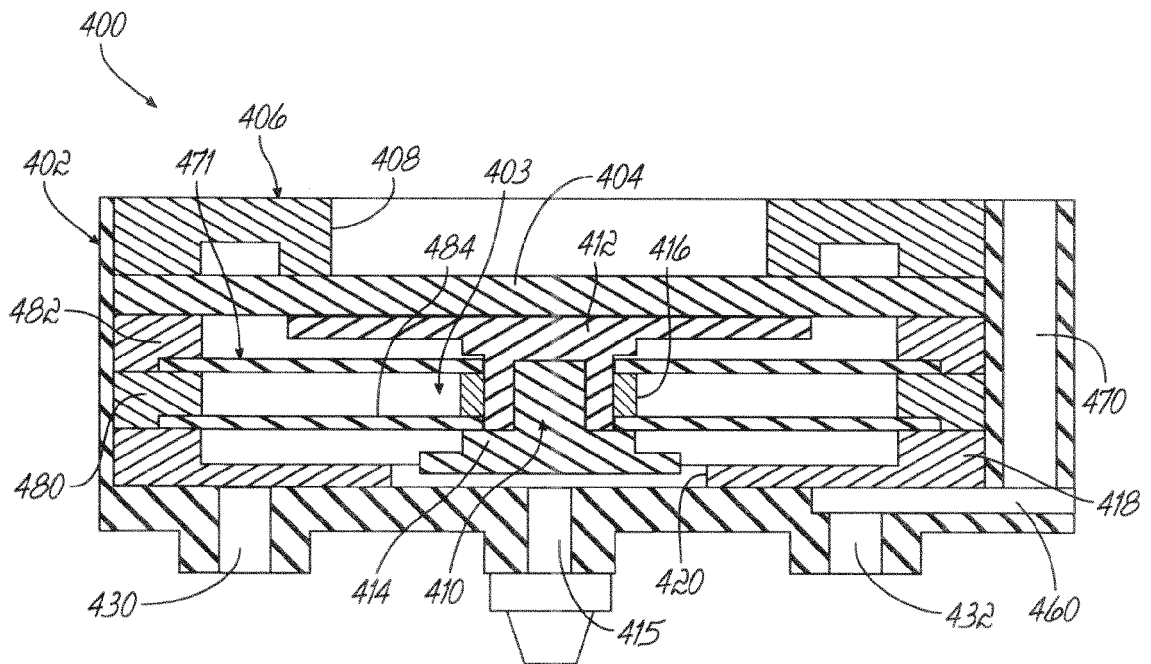

FIG. 18

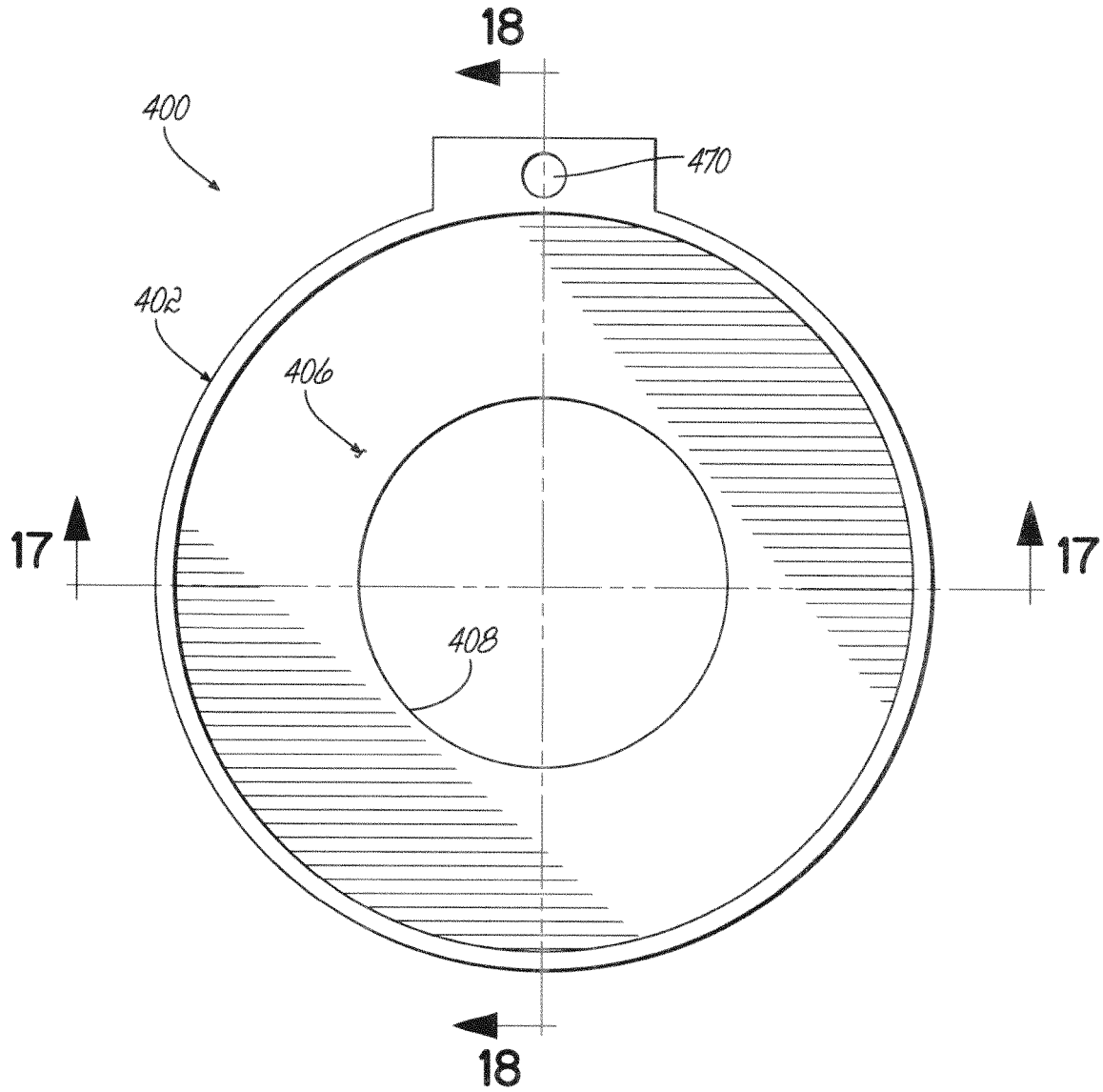

FIG. 19

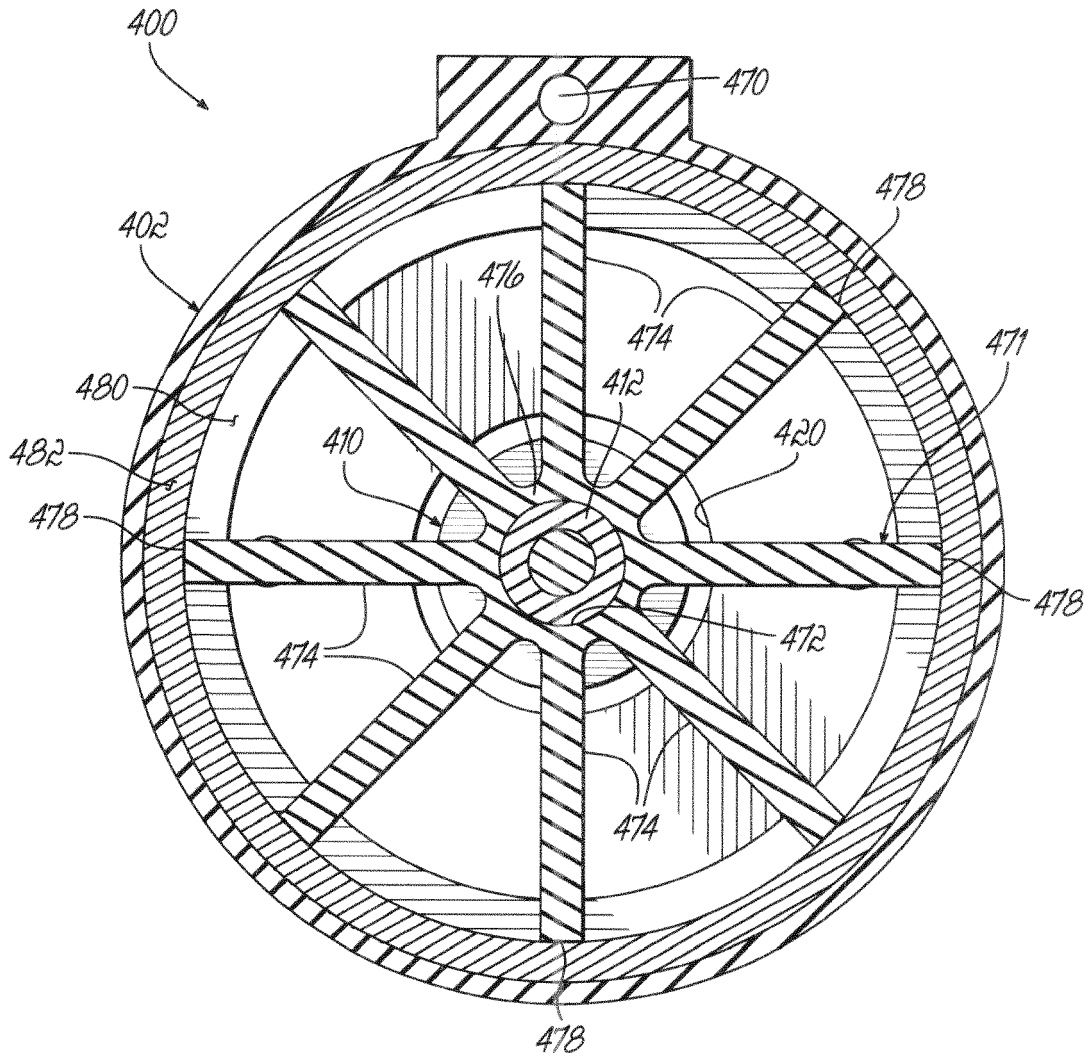

FIG. 20

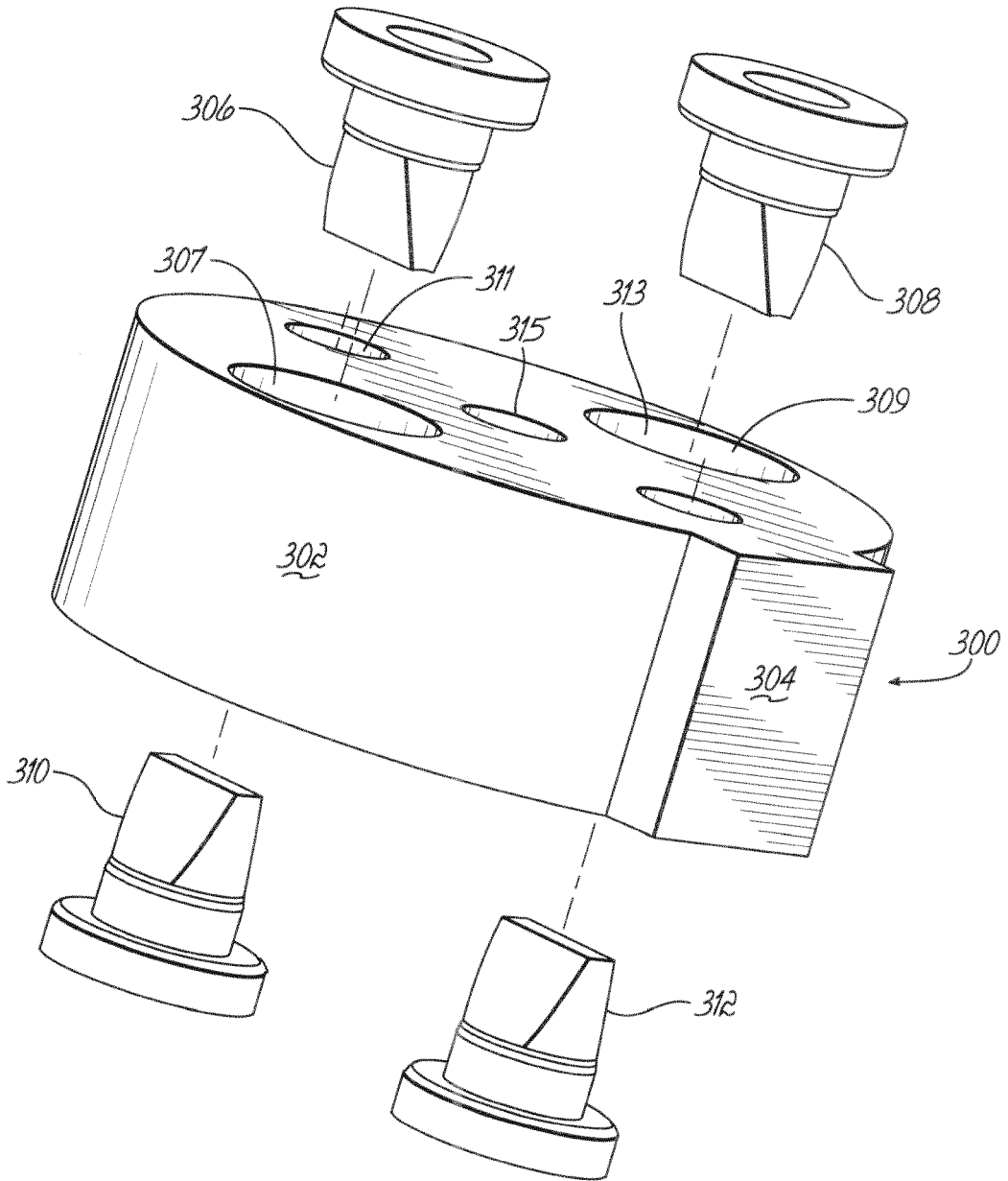

FIG. 21

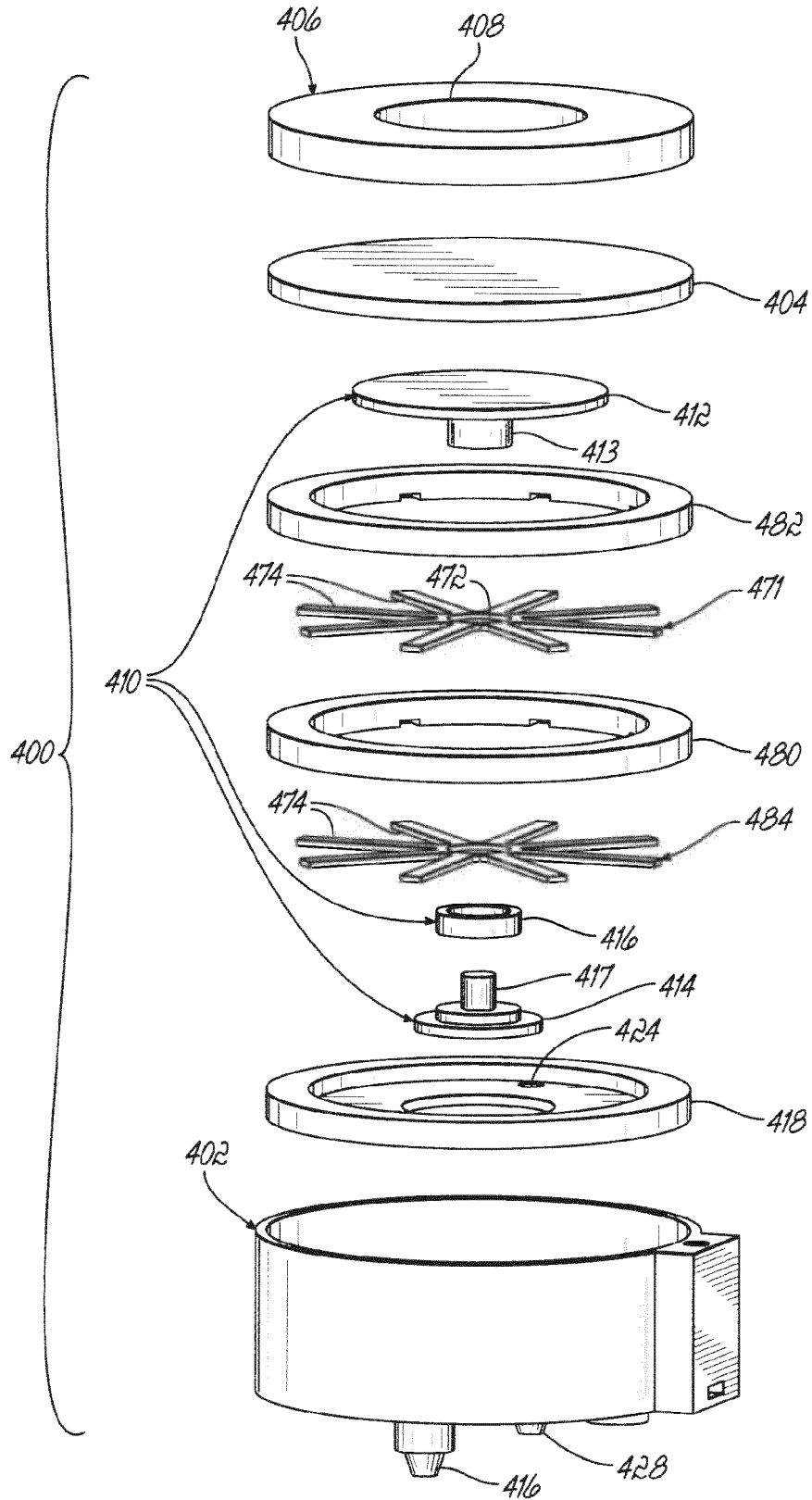

FIG. 22



EUROPEAN SEARCH REPORT

Application Number
EP 14 18 2070

5

10

15

20

25

30

35

40

45

50

55

DOCUMENTS CONSIDERED TO BE RELEVANT			
Category	Citation of document with indication, where appropriate, of relevant passages	Relevant to claim	CLASSIFICATION OF THE APPLICATION (IPC)
X, P	EP 2 746 073 A2 (GOODYEAR TIRE & RUBBER [US]) 25 June 2014 (2014-06-25) * the whole document *	1-15	INV. B60C23/12
A	EP 2 565 060 A1 (GOODYEAR TIRE & RUBBER [US]) 6 March 2013 (2013-03-06) * the whole document *	1-15	
			TECHNICAL FIELDS SEARCHED (IPC)
			B60C
The present search report has been drawn up for all claims			
Place of search Munich		Date of completion of the search 22 December 2014	Examiner Billen, Karl
CATEGORY OF CITED DOCUMENTS		T : theory or principle underlying the invention E : earlier patent document, but published on, or after the filing date D : document cited in the application L : document cited for other reasons & : member of the same patent family, corresponding document	
X : particularly relevant if taken alone Y : particularly relevant if combined with another document of the same category A : technological background O : non-written disclosure P : intermediate document			

EPO FORM 1503 03.82 (P04C01)

**ANNEX TO THE EUROPEAN SEARCH REPORT
ON EUROPEAN PATENT APPLICATION NO.**

EP 14 18 2070

5

This annex lists the patent family members relating to the patent documents cited in the above-mentioned European search report. The members are as contained in the European Patent Office EDP file on The European Patent Office is in no way liable for these particulars which are merely given for the purpose of information.

22-12-2014

10

Patent document cited in search report	Publication date	Patent family member(s)	Publication date
EP 2746073 A2	25-06-2014	BR 102013032256 A2	16-09-2014
		CN 103879243 A	25-06-2014
		EP 2746073 A2	25-06-2014
		JP 2014122023 A	03-07-2014
		US 2014174619 A1	26-06-2014

EP 2565060 A1	06-03-2013	BR 102012021803 A2	12-11-2013
		CN 102963222 A	13-03-2013
		EP 2565060 A1	06-03-2013
		JP 2013049413 A	14-03-2013
		US 2013048176 A1	28-02-2013

15

20

25

30

35

40

45

50

55

EPO FORM P0459

For more details about this annex : see Official Journal of the European Patent Office, No. 12/82