

(19)



(11)

EP 2 730 437 A1

(12)

EUROPEAN PATENT APPLICATION

(43) Date of publication:
14.05.2014 Bulletin 2014/20

(51) Int Cl.:
B60C 23/12 (2006.01) B60C 23/04 (2006.01)

(21) Application number: **13191496.2**

(22) Date of filing: **05.11.2013**

(84) Designated Contracting States:
AL AT BE BG CH CY CZ DE DK EE ES FI FR GB GR HR HU IE IS IT LI LT LU LV MC MK MT NL NO PL PT RO RS SE SI SK SM TR
Designated Extension States:
BA ME

- **Peronnet-Paquin, Anne Therese**
L-2566 Luxembourg (LU)
- **Haegel, Yannick**
F-59650 Villeneuve d'Ascq (FR)
- **Bonnet, Gilles**
L-9176 Niederfeulen (LU)

(30) Priority: **09.11.2012 US 201213672737**

(74) Representative: **Kutsch, Bernd**
Goodyear S.A.
Patent Department
Avenue Gordon Smith
7750 Colmar-Berg (LU)

(71) Applicant: **The Goodyear Tire & Rubber Company**
Akron, Ohio 44316 (US)

(72) Inventors:
• **Hinque, Daniel Paul Luc Marie**
B-6720 Habay-la-Neuve (BE)

(54) Securing to a pneumatic tire

(57) A pneumatic tire assembly comprising a pneumatic tire (10) having an inner cavity (12) and an inner surface (20) at least partially defining the inner cavity (12), a structure (22) for facilitating operation of the tire assembly, and a docking base (14) for securing the structure (22) to the inner surface (20) of the inner cavity (12) is disclosed. The docking base (14) is bonded to the inner surface (20) and has a shape which is formable by a mold attached to the inner surface (20) of the inner cavity (12) during a curing of the pneumatic tire (10). Also, system for maintaining air pressure within a cavity (12) of a pneu-

matic tire (10) is disclosed. A method for securing a device (30) to a pneumatic tire (10) comprises the steps of positioning a mold and green rubber within the mold on an inner surface (20) of an inner cavity (12) of a green tire; temporarily securing the mold and green rubber to the inner surface (20); locating the green tire within a vulcanizing press; curing the green tire by the vulcanizing press; removing the cured tire from the vulcanizing press; removing the mold from the inner surface; and securing the device (30) to a docking base (14) formed integral to the inner surface (20) by the mold.

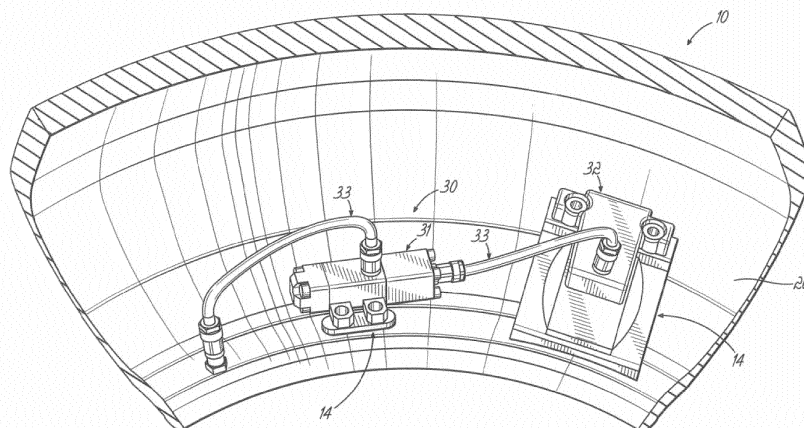

FIG. 4

EP 2 730 437 A1

Description

Field of the Invention

[0001] The invention relates generally to securing parts to a pneumatic tire and, more specifically, to securing parts of a pumping assembly to a pneumatic tire.

Background of the Invention

[0002] Normal air diffusion reduces tire pressure over time. The natural state of tires is under inflated. Accordingly, drivers must repeatedly act to maintain tire pressures or they will see reduced fuel economy, tire life and reduced vehicle braking and handling performance. Tire Pressure Monitoring Systems have been proposed to warn drivers when tire pressure is significantly low. Such systems, however, remain dependant upon the driver taking remedial action when warned to re-inflate a tire to recommended pressure. It is a desirable, therefore, to incorporate an air maintenance feature within a tire that will maintain air pressure within the tire in order to compensate for any reduction in tire pressure over time without the need for driver intervention. An air maintenance tire is described in EP-A-2 441 597

Summary of the Invention

[0003] The invention relates to a tire assembly in accordance with claim 1, to a system in accordance with claim 12, and to a method in accordance with claim 13.

[0004] Dependent claims refer to preferred embodiments of the invention.

[0005] A pneumatic tire assembly in accordance with the present invention may include a pneumatic tire having an inner cavity and an inner surface at least partially defining the inner cavity, a rigid structure for facilitating operation of the tire assembly, and a docking base for securing the rigid structure to the inner surface of the inner cavity. The docking base is preferably integrally bonded to the inner surface during curing of the pneumatic tire. The docking base has a shape formed by a mold attached to the inner surface of the inner cavity during curing of the pneumatic tire. The mold subsequently is removed thereby resulting in the docking base integrally secured to the inner surface.

[0006] According to another preferred aspect of the pneumatic tire assembly, the inner surface of the tire cavity maintains pressurized air within the inner cavity.

[0007] According to still another preferred aspect of the pneumatic tire assembly, the rigid structure is a hydraulic pump for maintaining air in the inner cavity of an air maintenance tire.

[0008] According to yet another preferred aspect of the pneumatic tire assembly, the mold is formed from silicone.

[0009] According to still another preferred aspect of the pneumatic tire assembly, the rigid structure is an elec-

tronic sensor.

[0010] According to yet another preferred aspect of the pneumatic tire assembly, the rigid structure is a balancing weight for the pneumatic tire.

[0011] According to still another preferred aspect of the pneumatic tire assembly, the rigid structure is an air compressor for maintaining air in the inner cavity of an air maintenance tire.

[0012] According to yet another preferred aspect of the pneumatic tire assembly, a second docking base may secure a second rigid structure to the inner surface of the inner cavity. The second docking base is preferably integrally bonded to the inner surface during curing of the pneumatic tire. The second docking base has a shape formed by a second mold attached to the inner surface of the inner cavity during curing of the pneumatic tire. The second mold subsequently is removed thereby resulting in the second docking base integrally secured to the inner surface.

[0013] According to still another preferred aspect of the pneumatic tire assembly, the rigid structure is a hydraulic pump for maintaining air in the inner cavity of an air maintenance tire and the second rigid structure is an air compressor for maintaining air in the inner cavity of the air maintenance tire.

[0014] According to yet another preferred aspect of the pneumatic tire assembly, the docking base includes a lever arm for facilitating operation of the rigid structure.

[0015] The method in accordance with the present invention secures a device to a pneumatic tire. The method comprises the steps of: positioning a mold and green rubber within the mold on an inner surface of an inner cavity of a green tire; securing the mold and green rubber to the inner surface; locating the green tire within a vulcanizing press; curing the green tire by the vulcanizing press; removing the cured tire from the vulcanizing press; removing the mold from the inner surface; and securing the device to a docking base formed integral to the inner surface by the mold.

[0016] According to a preferred aspect of the method, another step comprises filling the mold with green rubber.

[0017] According to another preferred aspect of the method, another step comprises applying heat and pressure by a bladder to the mold and surrounding green rubber thereby molding the rubber of the green tire and the green rubber within the mold together with an appropriate shape.

[0018] According to yet another preferred aspect of the method, another step comprises shaping the green rubber of the mold into a lever arm for facilitating operation of the device.

[0019] According to still another preferred aspect of the method, further steps include: securing a second mold and more green rubber to the inner surface prior to curing the green tire; removing the second mold from the inner surface subsequent to removing the cured tire from the vulcanizing press; and securing a second device to a second docking base formed integral to the inner sur-

face by the second mold.

[0020] A system in accordance with the present invention maintains air pressure within a cavity of a pneumatic tire. Preferably, the system includes a structure for facilitating operation of the system and a docking base for securing the structure to an inner surface of the cavity. The docking base is integrated to the inner surface during curing of the pneumatic tire. The docking base has a shape formed by a mold attached to the inner surface of the cavity during curing of the pneumatic tire. The mold subsequently is removed thereby resulting in the docking base integral to the inner surface.

[0021] According to a preferred aspect of the system or assembly, the docking base is shaped inverse correspondingly to the structure.

[0022] According to still another preferred aspect of the system or assembly, a second docking base for a second structure facilitates operation of the system.

[0023] According to yet another preferred aspect of the system or assembly, the structure is a hydraulic pump secured to the pneumatic tire by the docking base.

[0024] According to still another preferred aspect of the system or assembly, the second structure is an air compressor secured to the pneumatic tire by a second docking base.

[0025] A pneumatic tire assembly for use with the present invention preferably comprises: a tire having a pneumatic cavity; a rigid structure for facilitating operation of the tire assembly, the rigid structure being bonded to the tire by a layered thermoplastic material such that a stiffness gradient is created between the structure and the tire; first and second sidewalls extending respectively from first and second tire bead regions to a tire tread region, the first sidewall having at least one bending region operatively bending when radially within a rolling tire footprint; and a sidewall groove defined by groove walls positioned within the bending region of the first tire sidewall, the sidewall groove deforming segment by segment between a non-deformed state and a deformed, constricted state in response to bending of the bending region of the first sidewall while radially within the rolling tire footprint. An air passageway is defined by the sidewall groove and deforms segment by segment between an expanded condition and an at least partially collapsed condition in response to respective segment by segment deformation of the sidewall groove when radially within the rolling tire footprint.

[0026] According to another preferred aspect for use with the present invention, the thermoplastic material is selected from the group consisting of polyethylene, polypropylene, polyamide, polyester, polyphenylene ether, and polyphthalamide.

[0027] According to still another preferred aspect for use with the present invention, the thermoplastic material is polyethylene.

[0028] According to yet another preferred aspect for use with the present invention, the rigid structure further comprises an adhesive selected from the group consist-

ing of an RFL adhesive and an epoxy-based adhesive.

[0029] According to still another preferred aspect for use with the present invention, the thermoplastic material comprises a plurality of thermoplastic layers.

5 **[0030]** According to yet another preferred aspect for use with the present invention, the thermoplastic material comprises a plurality of thermoplastic layers wherein the thermoplastic layers have a layer thickness ranging from 0.1 to 1 mm.

10 **[0031]** According to still another preferred aspect for use with the present invention, the thermoplastic material comprises at least ten thermoplastic layers.

[0032] According to yet another preferred aspect for use with the present invention, the thermoplastic material comprises a plurality of thermoplastic layers with an adhesive disposed between the thermoplastic layers.

[0033] According to still another preferred aspect for use with the present invention, the thermoplastic material comprises at least ten thermoplastic layers with an adhesive disposed between the thermoplastic layers.

20 **[0034]** According to yet another preferred aspect for use with the present invention, the rigid structure is constructed of ultra high molecular weight polyethylene.

[0035] According to still another preferred aspect for use with the present invention, the rigid structure and the tire define a built-in tube-like cavity.

[0036] According to yet another preferred aspect for use with the present invention, the rigid structure and the tire reroute pressurized air to a pump assembly, and from there, into the pneumatic cavity.

30 **[0037]** According to still another preferred aspect for use with the present invention, a separate tube is disposed within the sidewall groove, the separate tube defining a circular air passageway.

35 **[0038]** According to yet another preferred aspect for use with the present invention, the separate tube has an outer profile corresponding to an inner profile of the sidewall groove.

[0039] According to still another preferred aspect for use with the present invention, the rigid structure comprises a plurality of check valves disposed at multiple arcuate positions about the sidewall groove.

40 **[0040]** According to yet another preferred aspect for use with the present invention, the rigid structure and the tire define a built-in tube-like cavity; and the rigid structure and the tire reroute pressurized air to a pump assembly, and from there, into the pneumatic cavity.

[0041] According to still another preferred aspect for use with the present invention, a subcoat is applied to a bare surface of the rigid structure; and a topcoat applied to the subcoat.

[0042] According to yet another preferred aspect for use with the present invention, the compound cement is applied to the topcoat.

55 **[0043]** According to still another preferred aspect for use with the present invention, the subcoat is dried to the bare surface of the rigid structure at 180°C for 8 min for instance.

Definitions

[0044] "Axial" and "axially" means lines or directions that are parallel to the axis of rotation of the tire.

[0045] "Circumferential" means lines or directions extending along the perimeter of the surface of the annular tread perpendicular to the axial direction.

[0046] "Equatorial Centerplane (CP)" means the plane perpendicular to the tire's axis of rotation and passing through the center of the tread.

[0047] "Footprint" means the contact patch or area of contact of the tire tread with a flat surface at zero speed and under normal load and pressure.

[0048] "Lateral" means an axial direction.

[0049] "Peristaltic" means operating by means of wave-like contractions that propel contained matter, such as air, along tubular pathways.

[0050] "Radial" and "radially" means directions radially toward or away from the axis of rotation of the tire.

Brief Description of the Drawings

[0051] The invention will be described by way of example and with reference to the accompanying drawings

Fig-1: Schematic perspective view of part of an example assembly in accordance with the present invention.

Fig-2: Schematic perspective view of another part of an example assembly in accordance with the present invention.

Fig-3: Schematic perspective view of part of another example assembly in accordance with the present invention.

Detailed Description of Examples of the Present Invention

[0052] An example tire assembly may include a tire, a peristaltic pump assembly, and a tire rim. The tire may mount in conventional fashion to a pair of rim mounting surfaces adjacent outer rim flanges. The rim flanges may each have a radially outward facing flange end. A rim body may support the tire assembly. The tire may be of conventional construction, having a pair of sidewalls extending from opposite bead areas to a crown or tire tread region. The tire and rim enclose a tire cavity.

[0053] The example peristaltic pump assembly may include an annular air tube that encloses an annular passageway. The tube may be formed of a resilient, flexible material such as plastic or rubber compounds that are capable of withstanding repeated deformation cycles of a flattened condition subject to external force and, upon removal of such force, returned to an original condition generally circular in cross-section. The tube may have a diameter sufficient to operatively pass a volume of air for purposes described herein and allowing a positioning of the tube in an operable location within the tire assembly.

In one example configuration, the tube may be an elongate, generally elliptical shape in cross-section, having opposite tube sidewalls extending from a flat (closed) trailing tube end to a radiused (open) leading tube end.

5 The tube may have a longitudinal outwardly projecting pair of locking detent ribs of generally semi-circular cross-section and each rib extending along outward surfaces of the sidewalls, respectively.

10 **[0054]** The example tube may have a length within a range of 3.65 mm to 3.80 mm; a width within a range of 2.2 mm to 3.8 mm; and a trailing end width within a range of 0.8 mm to 1.0 mm. The protruding detent ribs may each have a radius of curvature within a range of 0.2 mm to 0.5 mm and each rib may be located at a position
15 distance within a range of 1.8 mm to 2.0 mm of the trailing tube end. The leading end of the tube may have a radius within a range of 1.1 mm to 1.9 mm. The air passageway within the tube may likewise be generally elliptical with a length within a range of 2.2 mm to 2.3 mm; and a width
20 within a range of 0.5 mm to 0.9 mm.

[0055] The tube may be profiled and geometrically configured for insertion into a groove. The groove may have an elongate, generally elliptical configuration with a length within a range of 3.65 mm to 3.80 mm complementary to the elliptical shape of the tube. The groove
25 may include a restricted narrower entryway having a nominal cross-sectional width within a range of 0.8 mm to 1.0 mm. A pair of groove-rib receiving axial detent channels of semi-circular configuration may be formed within opposite sides of the groove for corresponding receipt
30 of the tube locking ribs. The channels may be spaced approximately a distance within a range of 1.8 mm to 2.0 mm of the groove entryway. Detent channels may each have a radius of curvature within a range of 0.2 mm to 0.5 mm. An inward detent groove portion may be formed with a radius of curvature within a range of 1.1 mm to 1.9 mm and a cross-sectional nominal width within
35 a range of 2.2 mm to 3.8 mm.

[0056] The tire may further form one or more compression ribs extending the circumference of, and projecting into, the groove. The ribs may form a pattern of ribs of prescribed pitch, frequency, and location. The ribs may be formed in a sequence and pitch pattern in order to optimize the pumping of air through the tube passageway. The ribs may each have a unique and predetermined height and placement within the pattern and project outward into the groove at a radius within a range
40 of 0.95 mm to 1.60 mm.

[0057] The peristaltic pump assembly may further include an inlet device and an outlet device are preferably spaced apart approximately 180 degrees at respective locations along the circumferential air tube. The example outlet device may have a T-shaped configuration in which conduits direct air to, and from, the tire cavity. An outlet
45 device housing may contain conduit arms that integrally extend from respective conduits. Each of the conduit arms may have external coupling ribs for retaining the conduits within disconnected ends of the air tube in the

assembled condition. The housing may be formed having an external geometry that complements the groove and includes a flat end, a radiused generally oblong body, and outwardly projecting longitudinal detent ribs. The housing may thus be capable of close receipt into the groove at its intended location with the ribs registering within the groove.

[0058] The inlet device may include an elongate outward sleeve body joining an elongate inward sleeve body at a narrow sleeve neck. The outward sleeve body may be generally triangular in section. The inward sleeve body may have an oblong external geometry complementary to the groove and may include a pair of detent ribs extending longitudinally along the inward sleeve body. An elongate air entry tube may be positioned within the inward sleeve body and may include opposite tube ends and a pattern of entry apertures extending into a central tube passageway. External ribs may secure the tube ends in the air tube opposite the outlet device.

[0059] The pump assembly may comprise the air tube and inlet and outlet devices affixed in-line to the air tube at respective locations preferably 180 degrees apart when inserted into the groove. The groove may be located at a lower sidewall region of the tire that, when the tire is mounted to the rim, positions the air tube above the rim flange ends. Upon full insertion, the ribs may register within the groove channels and the flat outer end of the tube may be generally coplanar with the outer surface of the sidewall of the tire. Once fully inserted, the air passageway of the tube may elastically restore itself into an open condition to allow the flow of air along the tube during operation of the pump.

[0060] The inlet device and the outlet device may be positioned within the circumference of the circular air tube generally 180 degrees apart. The tire with the tube positioned within the groove rotates in a direction of rotation, causing a footprint to be formed against the ground surface. A compressive force is directed into the tire from the footprint and acts to flatten a segment of the air tube passageway adjacent the footprint. Flattening of a segment of the passageway forces air from the segment along the tube passageway in a direction toward the outlet device.

[0061] As the tire continues to rotate along the ground surface, the tube may be sequentially flattened or squeezed adjacent the tire footprint, segment by segment, in a direction opposite to the direction rotation. A sequential flattening of the tube passageway, segment by segment, may cause evacuated air from the flattened segments to be pumped in the direction of rotation within the tube passageway toward the outlet device. Air may flow through the outlet device and to the tire cavity. Air exiting the outlet device may be routed to the tire cavity and serve to reinflate and/or sustain the tire at a desired pressure level. A valve system to regulate the flow of air to the cavity, when the air pressure within the cavity falls to a prescribed level, is shown and described in US-A-2011/0272073, Patent Applicant Serial No. 13/561,155,

filed July 30, 2012.

[0062] With the tire rotates, flattened tube segments may be sequentially refilled by air flowing into the inlet device. The inflow of air into the inlet device, and then into the tube passageway, may continue until the outlet device, rotating in a counterclockwise direction, moves away from or passes the tire footprint. The tube may continue to be sequentially flattened, segment by segment, adjacent the tire footprint by a compressive force of the vehicle load. Air may be pumped in the clockwise direction to the inlet device and evacuated or exhausted external to the tire. Passage of exhaust air from the inlet device may occur through a filter sleeve exemplarily formed of a cellular or porous material or composite. Flow of air through the filter sleeve and into the tube may thus cleanse debris or particulates from the inlet air. In an exhaust or reverse flow of air direction, the filter sleeve may be cleansed of trapped accumulated debris or particles within the porous medium. With the evacuation of pumped air out of the inlet device, the outlet device may be in a closed position preventing air flow to the tire cavity. When the tire rotates further in a counterclockwise direction until the inlet device moves toward the tire footprint, the airflow may resume to the outlet device and cause the pumped air to flow into the tire cavity. Air pressure within the tire cavity may thus be maintained at a desired level.

[0063] The tube may be flattened, segment by segment, as the tire rotates. A flattened segment may move counterclockwise as it is rotated away from the tire footprint while an adjacent segment moves adjacent the tire footprint and is flattened. Accordingly, the progression of squeezed or flattened or closed tube segments may move air toward the outlet device or the inlet device depending on the rotational position of the tire relative to these devices. As each segment is moved by tire rotation away from the tire footprint, the compression forces within the tire from the footprint region may be eliminated and the segment may resiliently reconfigure into an unsqueezed or unflattened or open condition as the segment refills with air from the passageway. In the original non-flattened configuration, segments of the tube may resume the exemplary oblong generally elliptical cross-sectional shape.

[0064] The above-described cycle may repeat for each tire revolution, with half of each rotation resulting in pumped air to the tire cavity and half of each rotation resulting in pumped air moving back out the filter sleeve of the inlet device for selfcleaning of the filter. It may be appreciated that while the direction of rotation of the tire may be counterclockwise, the example tire assembly and its peristaltic pump assembly may function in a like manner in a clockwise direction of rotation as well. The peristaltic pump assembly may accordingly be bi-directional and equally functional with the tire and vehicle moving in a forward or reverse direction of rotation and forward or reverse direction of the vehicle.

[0065] The tube may be located within the groove in a

lower region of the sidewall of the tire. The passageway of the tube may close by compression strain bending of the sidewall groove within or adjacent the rolling tire footprint. The location of the tube in the sidewall may provide freedom of placement thereby avoiding contact between the tube and the rim. Higher placement of the tube in the sidewall groove may use high deformation characteristics of this region of the sidewall as it passes through or adjacent the tire footprint to close the tube.

[0066] The configuration and operation may be a variable pressure pump compression of the tube by operation of ridges or compression ribs within the groove. The groove may be uniform width circumferentially along the side of the tire with the molded ridges/ribs formed to project into the groove in a preselected sequence, pattern, or array. The ridges may retain the tube in a predetermined orientation within the groove and also may apply a variable sequential constriction/closing force to the tube.

[0067] The uniformly dimensioned pump tube may be positioned within the groove by mechanically spreading the entryway of the groove apart. The tube may then be inserted into the enlarged entryway of the groove. The entryway of the groove may thereafter be released to return to close into its original spacing thereby capturing the tube inside the groove. Longitudinal locking ribs of the tube may thus be capture/lock the tube into the longitudinal groove. The locking ribs resultingly operate to lock the tube inside the groove and prevent ejection of the tube from the groove during tire operation/rotation. Alternatively, the tube may be pressed into the groove.

[0068] The tube, being of uniform width dimensions and geometry, may be manufactured in large quantities. Moreover, a uniform dimensioned pump tube may reduce overall assembly time, material cost, and non-uniformity of tube inventory. From a uniformity perspective, this results in less scrap.

[0069] The circumferential ridges projecting into the groove may increase in frequency (number of ridges per axial groove unit of length) toward the inlet passage of the tube, adjacent the outlet device. Each of the ridges may have a common radius dimension within a range of 0.15 mm to 0.30 mm. The spacing between ridges may be largest, the spacing between the next largest, and so on until the spacing between ridges is nominally eliminated. More or fewer ridges may be deployed at various frequencies along the groove.

[0070] The projection of the ridges into the groove by a radius may serve a twofold purpose. First, the ridges may engage the tube and prevent the tube from migrating, or "walking", along the groove during tire operation/rotation from the intended location of the tube. Secondly, the ridges may compress the segment of the tube opposite each ridge to a greater extent as the tire rotates through its rotary pumping cycle. The flexing of the sidewall may manifest a compression force through each ridge and may constrict/close the tube segment adjacent such ridge to a greater extent than otherwise would occur

in tube segments adjacent non-ridged portions of the groove. As the frequency of the ridges increases in the direction of air flow, a pinching of the tube passageway may progressively occur until the passageway constricts, gradually reducing the air volume and increasing the air pressure.

[0071] As a result, with the presence of the ridges, the groove may provide variable pumping pressure within the tube configured to have a uniform dimension therealong. As such, the sidewall groove may be a variable pressure pump groove functioning to apply a variable pressure to a tube situated within the groove. It will be appreciated that the degree of pumping pressure variation may be determined by the pitch or ridge frequency within the groove and the amplitude of the ridges deployed relative to the diametric dimensions of the tube passageway. The greater the ridge amplitude relative to the diameter, the more air volume may be reduced in the tube segment adjacent the ridge and pressure increased, and vice versa.

[0072] From the forgoing, it will be appreciated that the example assembly may comprise a bi-directionally peristaltic pump assembly for air maintenance of a tire. The circular air tube may flatten, segment by segment, and close when adjacent the tire footprint. The air inlet device may include an outer filter sleeve formed of porous cellular material and thereby render the air inlet device self-cleaning. The outlet device may employ a valve unit. The peristaltic pump assembly may pump air through rotation of the tire in either direction, one half of a revolution pumping air to the tire cavity and the other half of a revolution pumping air back out of the inlet device. The peristaltic pump assembly may be used with a secondary tire pressure monitoring system (TPMS) (not shown) that may serve as a system fault detector. The TPMS may be used to detect any fault in the self-inflation system of the tire assembly and alert the user of such a condition.

[0073] The tire air maintenance system may further incorporate a variable pressure pump groove with one or more inwardly directed ridges or ribs engaging and compressing a segment of the air tube adjacent such rib(s). The pitch or frequency of the ribs may increase toward the outlet device for gradually reducing air volume within the passageway by compressing the tube. The reduction in air volume may increase air pressure within the passageway and thereby facilitate a more efficient air flow from the tube into the tire cavity. The increase in tube pressure may be achieved by engagement by the ribs of the groove and the tube having uniform dimensions along the tube length. The tube may thus be made of uniform dimension and of relatively smaller size without compromising the flow pressure of air to the tire cavity for maintaining air pressure. The pitch and amplitude of the ridges may both be varied to better achieve the desired pressure increase within the passageway.

[0074] Structures in a pneumatic tire may require the attaching or securing of certain parts, functional devices, and/or connectors to a rubber part of the tire (e.g., the

innerliner). For example, the structures of the example air maintenance tire described above may require attaching to the tire within the tire cavity. Such structures typically encounter high stresses during operating conditions of the tire. Thus, strong attachment of such structures is desired since a bond break at the structure's surface will likely lead to destruction of the assembly and/or the integrity of the tire as a whole.

[0075] A method in accordance with the present invention molds a shape on the inside surface/innerliner of a tire cavity. The method may include the step of filling a silicone mold/patch with green rubber and place it on the inside of the tire cavity of the green tire. The inner surface of the mold may be shaped correspondingly to the object to be secured/molded to the inside surface/innerliner of the pneumatic tire. After the installation of the silicone mold containing the green rubber on the surface of the green tire, the green tire and silicone mold are cured in a vulcanizing press.

[0076] The bladder of the vulcanizing press may apply pressure and heat to the silicone mold and surrounding green rubber thereby molding the rubber of the green tire with the appropriate shape and curing/vulcanizing/stabilizing the rubber around the silicone mold. The silicone mold may then be removed after the tire is removed from the press. Such a method may form a docking base for the hydraulic pump (AMT) described above. Further, the method may create any fixation system inside the cured pneumatic tire (e.g., for an electronic or other sensor, a balancing weight, an air compressor, etc). Additionally, the silicone mold may shape the rubber of the green tire into a functioning device such as a lever arm for facilitating actuation of a hydraulic pump.

[0077] Such a method is illustrated in FIGS. 1-3. A method in accordance with the present invention may mold a shape for mounting on the inside surface such as an innerliner 20 of a tire cavity 12 of a pneumatic tire 10. The method may fill a silicone mold or a patch 16 with green rubber and place it on the inside of the tire cavity 12 of the green tire. The inner surface of the mold or patch 16 may be shaped inverse correspondingly to the object 22 to be secured/molded to the inside surface/innerliner 20 of the pneumatic tire 10 (FIGS. 2-3). After temporary installation of the mold/patch 16 (such as a silicone mold) containing the green rubber on the surface 20 of the green tire, the green tire and mold/patch 16 may be cured in a vulcanizing press. The mold/green rubber may be temporarily secured to the green tire by any suitable method.

[0078] The bladder of the vulcanizing press may apply pressure and heat to the silicone mold 16 and surrounding green rubber thereby molding the rubber of the green tire with the appropriate shape and curing/vulcanizing/stabilizing the rubber within and around the silicone mold thereby forming a docking base 14 integral to the inner surface 20 of the pneumatic tire 10 (FIG. 1). The silicone mold 16 may then be removed after the pneumatic tire 10 is removed from the press. Such a method

may form a docking base 14 for the hydraulic pump (AMT) 22 described above (FIG. 2). Further, the method may create any fixation system inside the cured pneumatic tire 10 (e.g., for a sensor, a balance weight, an air compressor, etc). Additionally, the silicone mold 16 may shape the rubber of the green tire into a functioning device such as a lever arm 18 for facilitating actuation of a hydraulic pump 22 (FIG. 3). In operation, the inner surface/innerliner/sidewall 20 of the pneumatic tire 10 may flex when adjacent the tire footprint thereby flexing the docking base 14 and lever arm 18. The docking base 14 and lever arm 18 may thus actuate/deform the hydraulic pump 22 periodically or once every rotation of the pneumatic tire 10.

[0079] FIG. 4 shows another device 30, such as a two piece hydraulic pump, installed using the method in accordance with the present invention. The device 30 may include two pieces 31, 32 mounted to the innerliner/sidewall 20 and interconnected by tubing 33. Each piece 31, 32 may be attached to the innerliner/sidewall 20 with its own docking base 14.

Claims

1. A pneumatic tire assembly comprising a pneumatic tire (10) having an inner cavity (12) and an inner surface (20) at least partially defining the inner cavity (12), a structure (22) for facilitating operation of the tire assembly, and a docking base (14) for securing the structure (22) to the inner surface (20) of the inner cavity (12), wherein the docking base (14) is bonded to the inner surface (20) and has a shape which is formable by a mold attached to the inner surface (20) of the inner cavity (12) during a curing of the pneumatic tire (10).
2. The pneumatic tire assembly as set forth in claim 1 wherein the inner surface (20) of the inner cavity (12) is for maintaining pressurized air within the inner cavity (12).
3. The pneumatic tire assembly as set forth in claim 1 or 2 wherein the structure (22) is a hydraulic pump for maintaining air in an inner cavity (12) of an air maintenance tire, wherein the structure (22) is an electronic sensor, wherein the structure (22) is a balancing weight for the pneumatic tire (10), or wherein the structure (22) is an air compressor for maintaining air in an inner cavity (12) of an air maintenance tire.
4. The pneumatic tire assembly as set forth in claim 1, 2 or 3 wherein the structure (22) is secured to the pneumatic tire (10) by the docking base (14).
5. The pneumatic tire assembly as set forth in at least one of the previous claims further including a second

docking base for securing a second structure to the inner surface (10) of the inner cavity (12) or for facilitating operation of the pneumatic tire assembly.

6. The pneumatic tire assembly as set forth in claim 5 wherein the second docking base is bonded to the inner surface (20) and has a shape which is formable by a mold attached to the inner surface (20) of the inner cavity (12) during a curing of the pneumatic tire (10). 5
7. The pneumatic tire assembly as set forth in claim 5 or 6 wherein the structure (20) is a hydraulic pump for maintaining air in an inner cavity of an air maintenance tire and the second structure is an air compressor for maintaining air in the inner cavity of the air maintenance tire. 10
8. The pneumatic tire assembly as set forth in at least one of the previous claims wherein the docking base (14) includes a lever arm (18) for facilitating operation of the structure (22) during a rotation of the pneumatic tire (10) under a load. 15
9. The pneumatic tire assembly system as set forth in at least one of the previous claims wherein the docking base (14) is shaped inverse correspondingly to the structure (22) and/or wherein the second docking base is shaped inverse correspondingly to the second structure. 20
10. The system as set forth in at least one of the previous claims wherein the second structure is an air compressor secured to the pneumatic tire (10) by the second docking base. 25
11. The pneumatic tire assembly as set forth in at least one of the previous claims wherein the structure (20) and/or the second structure is a rigid structure. 30
12. A system for maintaining air pressure within a cavity (12) of a pneumatic tire (10), the system comprising a pneumatic tire assembly in accordance with at least one of the previous claims. 35
13. A method for securing a device (30) to a pneumatic tire (10), the method comprising the steps of: 40

positioning a mold and green rubber within the mold on an inner surface (20) of an inner cavity (12) of a green tire; 50

temporarily securing the mold and green rubber to the inner surface (20);

locating the green tire within a vulcanizing press;

curing the green tire by the vulcanizing press; 55

removing the cured tire from the vulcanizing press;

removing the mold from the inner surface; and

securing the device (30) to a docking base (14) formed integral to the inner surface (20) by the mold.

14. The method as set forth in claim 13 further including the step of applying heat and pressure by a bladder to the mold and surrounding green rubber thereby molding the rubber of the green tire and the green rubber within the mold together with an appropriate shape; and/or further including the step of shaping the green rubber of the mold into a lever arm for facilitating operation of the device (30) during rotation of the pneumatic tire (10) under a load. 10
15. The method as set forth in claim 13 or 14 further including the steps of: 15

temporarily securing a second mold and more green rubber to the inner surface (20) prior to curing the green tire;

removing the second mold from the inner surface subsequent to removing the cured tire from the vulcanizing press; and

securing a second device to a second docking base formed integral to the inner surface by the second mold. 20

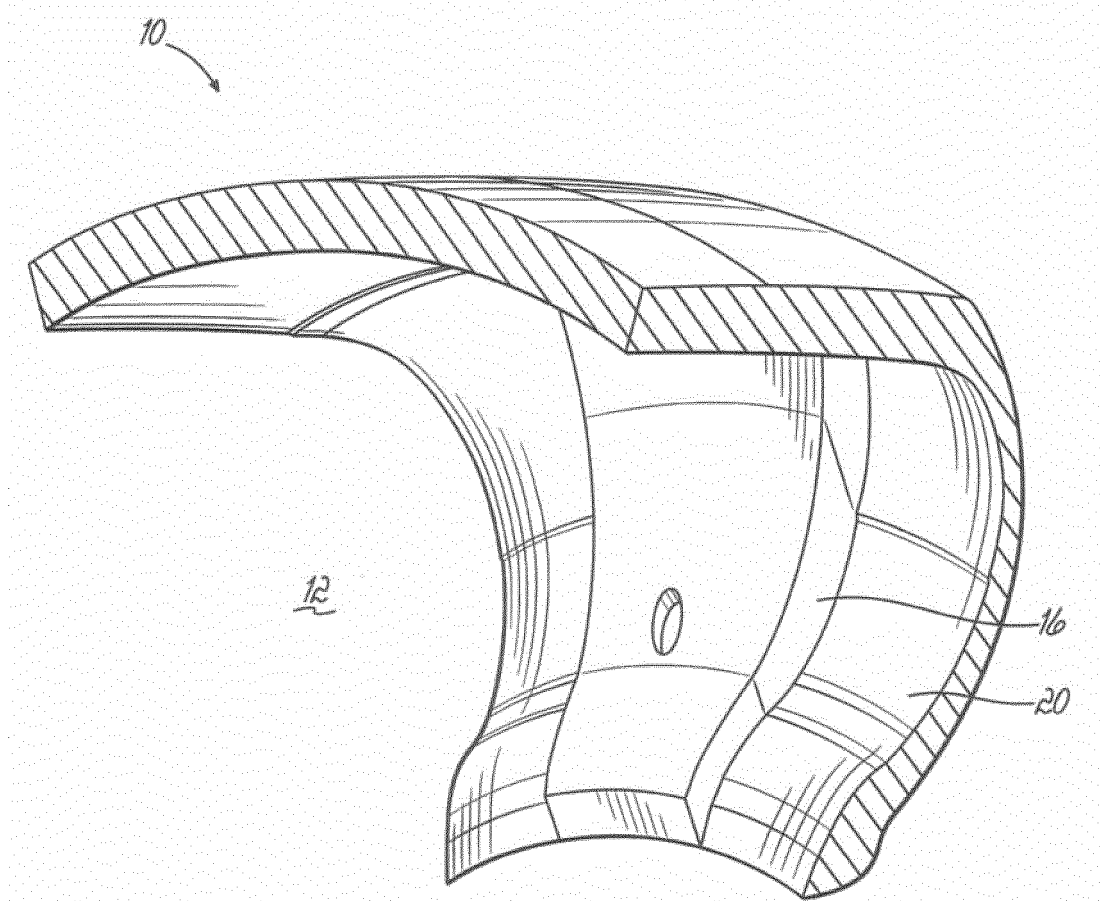
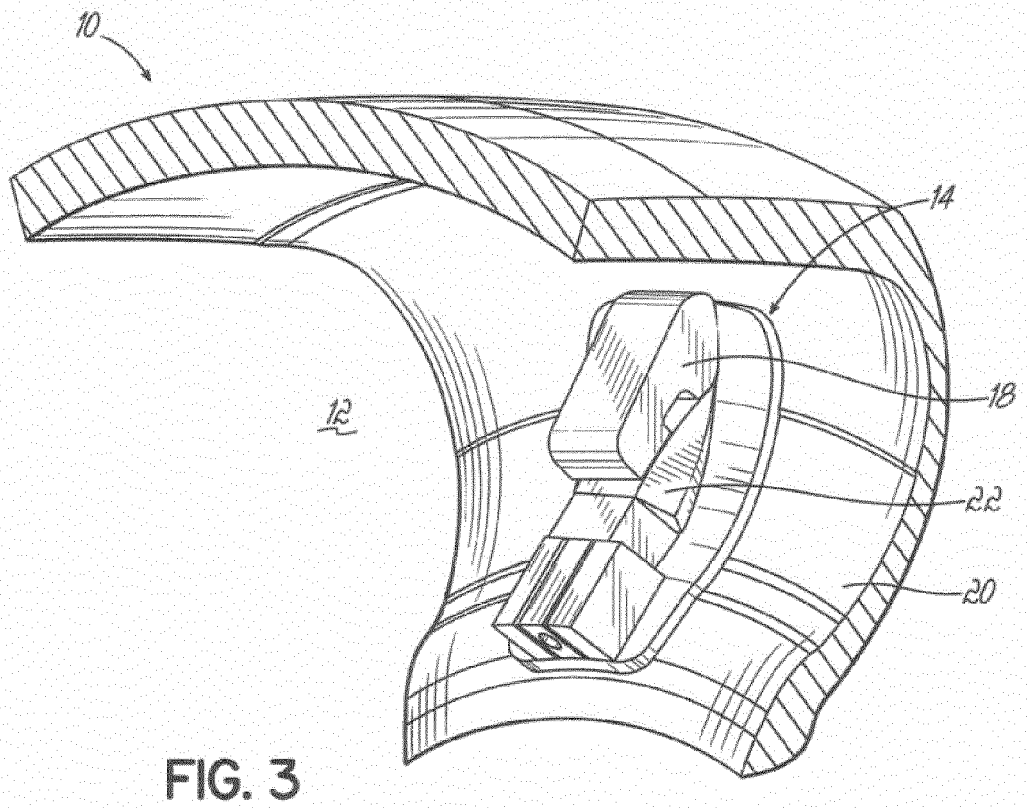
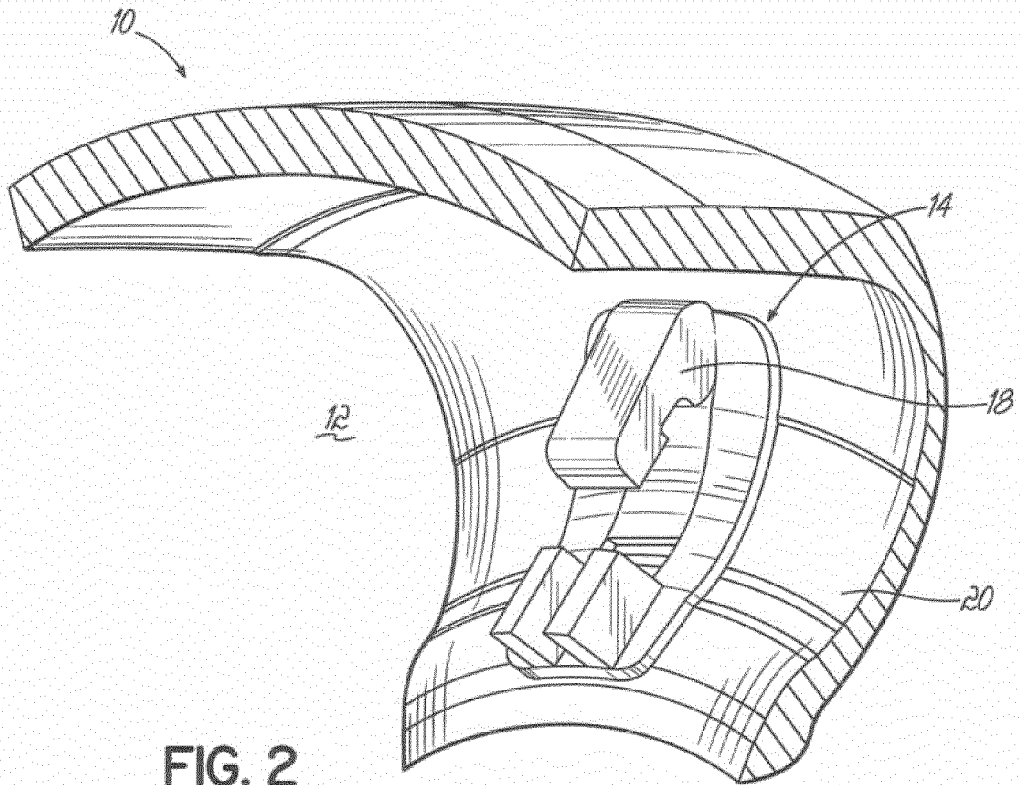

FIG. 1



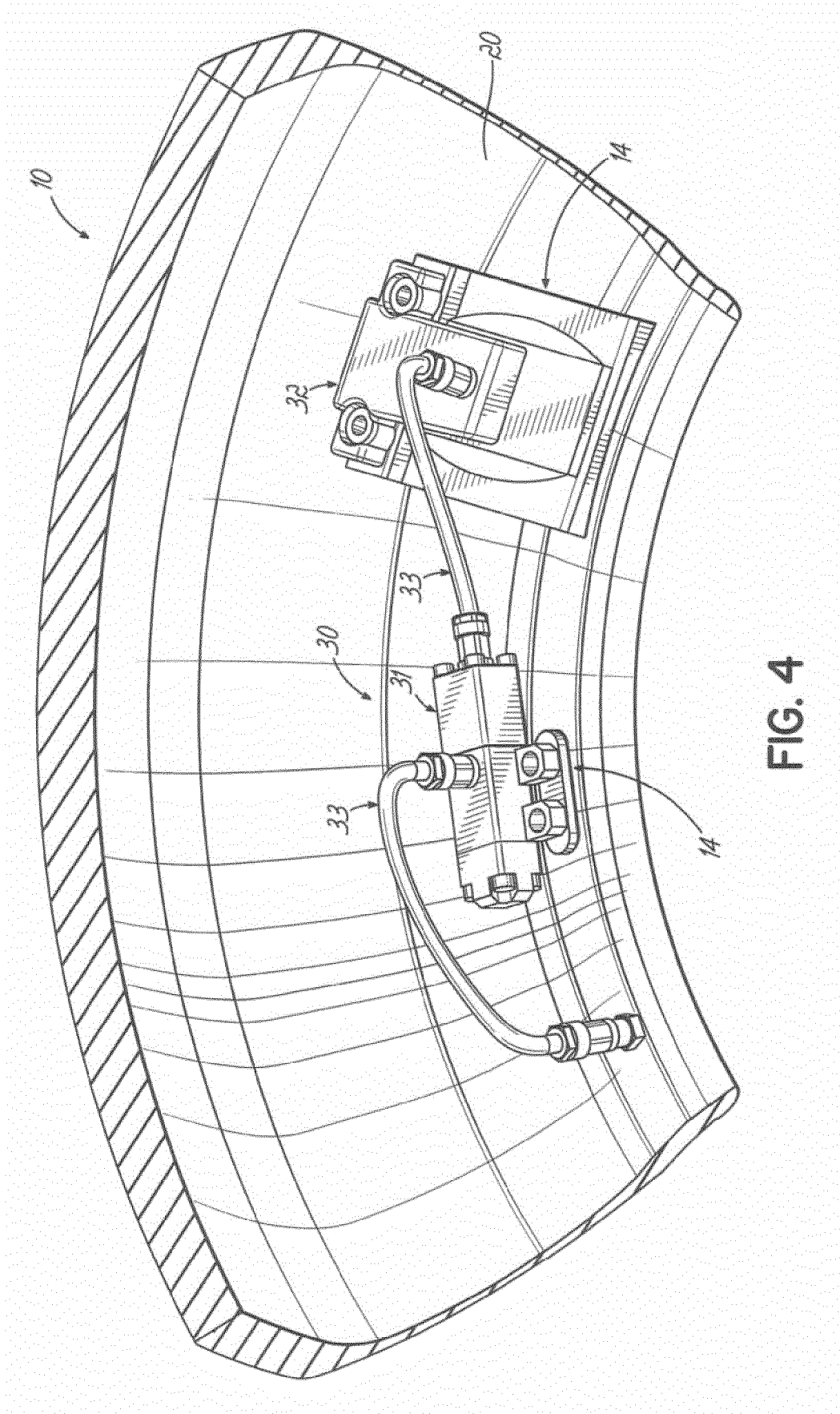

FIG. 4



EUROPEAN SEARCH REPORT

Application Number
EP 13 19 1496

DOCUMENTS CONSIDERED TO BE RELEVANT			
Category	Citation of document with indication, where appropriate, of relevant passages	Relevant to claim	CLASSIFICATION OF THE APPLICATION (IPC)
X	EP 1 721 760 A1 (BRIDGESTONE CORP [JP]) 15 November 2006 (2006-11-15)	1-6,9, 11-15	INV. B60C23/12 B60C23/04
Y	* paragraph [0028] - paragraph [0054] *	8	
A	* paragraph [0051] - paragraph [0054] * * figures 1-11 *	7,10	
Y	----- US 5 562 787 A (KOCH RUSSELL W [US] ET AL) 8 October 1996 (1996-10-08) * figures 11,12 * -----	8	
			TECHNICAL FIELDS SEARCHED (IPC)
			B60C B29D
The present search report has been drawn up for all claims			
Place of search Munich		Date of completion of the search 4 February 2014	Examiner Billen, Karl
CATEGORY OF CITED DOCUMENTS X : particularly relevant if taken alone Y : particularly relevant if combined with another document of the same category A : technological background O : non-written disclosure P : intermediate document		T : theory or principle underlying the invention E : earlier patent document, but published on, or after the filing date D : document cited in the application L : document cited for other reasons & : member of the same patent family, corresponding document	

1
EPO FORM 1503 03/02 (P04C01)

ANNEX TO THE EUROPEAN SEARCH REPORT
ON EUROPEAN PATENT APPLICATION NO.

EP 13 19 1496

This annex lists the patent family members relating to the patent documents cited in the above-mentioned European search report.
The members are as contained in the European Patent Office EDP file on
The European Patent Office is in no way liable for these particulars which are merely given for the purpose of information.

04-02-2014

Patent document cited in search report	Publication date	Patent family member(s)	Publication date
EP 1721760 A1	15-11-2006	EP 1721760 A1	15-11-2006
		JP 4573831 B2	04-11-2010
		US 2007169865 A1	26-07-2007
		WO 2005082644 A1	09-09-2005

US 5562787 A	08-10-1996	AU 694200 B2	16-07-1998
		AU 2030295 A	14-12-1995
		AU 6596998 A	16-07-1998
		BR 9502667 A	02-01-1996
		CA 2150865 A1	04-12-1995
		DE 69509305 D1	02-06-1999
		DE 69509305 T2	02-09-1999
		EP 0689950 A2	03-01-1996
		ES 2130524 T3	01-07-1999
		JP 3683008 B2	17-08-2005
		JP 4034316 B2	16-01-2008
		JP H0867117 A	12-03-1996
		JP 2005233968 A	02-09-2005
		NZ 272255 A	26-06-1998
		US 5500065 A	19-03-1996
		US 5562787 A	08-10-1996
		US 5573610 A	12-11-1996
US 5573611 A	12-11-1996		
ZA 9504299 A	24-01-1996		

REFERENCES CITED IN THE DESCRIPTION

This list of references cited by the applicant is for the reader's convenience only. It does not form part of the European patent document. Even though great care has been taken in compiling the references, errors or omissions cannot be excluded and the EPO disclaims all liability in this regard.

Patent documents cited in the description

- EP 2441597 A [0002]
- US 20110272073 A [0061]
- US 13561155 B [0061]