



(11) **EP 2 502 760 A1**

(12) **EUROPEAN PATENT APPLICATION**

(43) Date of publication:
26.09.2012 Bulletin 2012/39

(51) Int Cl.:
B60C 23/12 (2006.01)

(21) Application number: **12160852.5**

(22) Date of filing: **22.03.2012**

(84) Designated Contracting States:
AL AT BE BG CH CY CZ DE DK EE ES FI FR GB GR HR HU IE IS IT LI LT LU LV MC MK MT NL NO PL PT RO RS SE SI SK SM TR
Designated Extension States:
BA ME

(72) Inventors:
• **Hinque, Daniel Paul Luc Marie**
B-6720 Habay-la-Neuve (BE)
• **Haegel, Yannick**
F-59650 Villeneuve d'Ascq (FR)

(30) Priority: **23.03.2011 US 201113069496**

(74) Representative: **Kutsch, Bernd**
Goodyear SA
Patent Department
Avenue Gordon Smith
7750 Colmar-Berg (LU)

(71) Applicant: **The Goodyear Tire & Rubber Company**
Akron, OH 44316-0001 (US)

(54) **Tire system and method of maintaining air in a tire**

(57) A tire system and a method of maintaining air in a pneumatic tire is disclosed. The system comprises a tire having a tire carcass comprising a tire cavity defined by a tire inner liner, and first and second sidewalls extending respectively from first and second tire bead regions to a tire tread region; compression actuator means (19) mounted to the tire carcass configured for operative actuation by tire deformation during a tire revolution; and a pump assembly (20) affixed to the tire carcass and comprising a compressor body (62) affixed to the compression actuator means and having an internal air chamber (64). The internal air chamber has an inlet opening (66) for admitting air into the internal air chamber and an outlet opening (70) for conducting air from the internal air chamber to the tire cavity. The compressor body (62) further comprises a piston valve member (74) operationally moving within the internal air chamber responsive to actuation by or contacting engagement with the compression actuator means (19) to compress air within the internal air chamber (64).

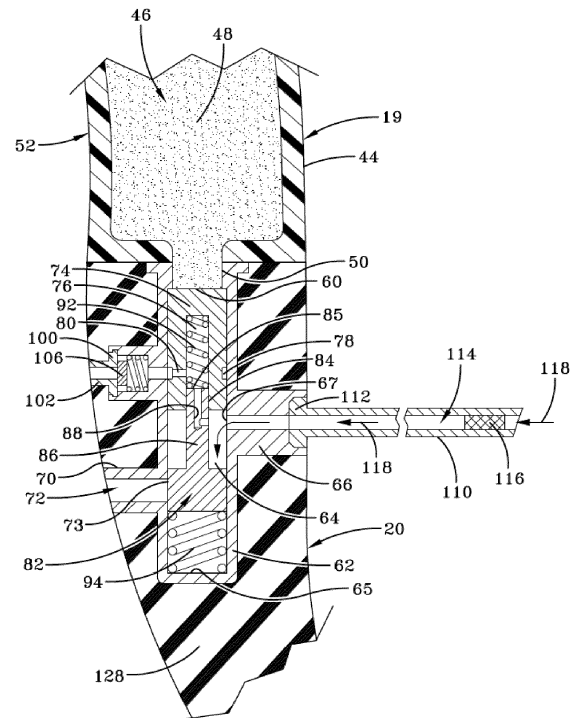

FIG-6A

EP 2 502 760 A1

Description

Field of the Invention

[0001] The invention relates generally to a tire system and a method of maintaining air in a tire and more specifically to an air maintenance tire and to a tire having an integrated air pumping system.

Background of the Invention

[0002] Normal air diffusion reduces tire pressure over time. The natural state of tires is under inflated. Accordingly, drivers must repeatedly act to maintain tire pressures or they will see reduced fuel economy, tire life and reduced vehicle braking and handling performance. Tire Pressure Monitoring Systems (TPMS) have been proposed to warn drivers when tire pressure is significantly low. Such systems, however, remain dependant upon the driver taking remedial action when warned to re-inflate a tire to recommended pressure. It is a desirable, therefore, to incorporate an air maintenance feature within a tire that will auto-maintain air pressure within the tire.

Summary of the Invention

[0003] The invention relates to a tire system in accordance with claim 1 and to a method in accordance with claim 13.

[0004] Dependent claims refer to preferred embodiments of the invention.

[0005] In one preferred aspect of the invention, an air-maintenance tire system includes a compression actuator mounted to the tire carcass configured for operative actuation by tire deformation during a tire revolution, a pump assembly affixed to the tire carcass and including a compressor body affixed to the compression actuator and having an internal air chamber, the air chamber having an inlet opening for admitting air into the internal air chamber and an outlet opening for conducting air from the internal air chamber to the tire cavity. The air compressor body further includes a piston valve member and an outlet valve member located within and at opposite respective ends of the internal air chamber, the piston valve member and the outlet valve member moving within the internal air chamber responsive to actuation by the compression actuator between respective open and closed positions, whereby cyclically opening and closing the inlet and the outlet openings during an air compression cycle.

[0006] In another preferred aspect, the piston valve member in the open position relative to the inlet opening permits air flow from the inlet opening into the air chamber and in the closed position relative to the inlet opening obstructs air flow from the inlet opening into the air chamber, and wherein the piston valve member during movement between the open and closed positions operatively compresses a volume of air within the air chamber.

[0007] According to a preferred further aspect, the outlet valve member in the closed position relative to the outlet opening is operative to move to the open position responsive to air pressure within the air chamber reaching a preset threshold wherein permitting air flow from the air chamber into the outlet opening.

[0008] In accordance with a preferred aspect of the invention, the compression actuator is a hollow containment body formed from a resilient deformable material composition and containing a quantity of a non-compressible medium. The containment body is preferably affixed to a relatively high flex-deformation region of the tire carcass and reciprocally transforms between a deformed state and a non-deformed state responsive to deformation and recovery of the tire high flex-deformation region in a rolling tire. The actuator containment body in the deformed state displaces a pressurized displaced quantity of the non-compressible medium which generates a compression force against a piston valve member surface to move the piston valve between the open and closed positions within the air chamber.

Definitions

[0009] "Aspect ratio" of the tire means the ratio of its section height (SH) to its section width (SW) multiplied by 100 percent for expression as a percentage.

[0010] "Axial" and "axially" means lines or directions that are parallel to the axis of rotation of the tire.

[0011] "Circumferential" means lines or directions extending along the perimeter of the surface of the annular tread perpendicular to the axial direction.

[0012] "Footprint" means the contact patch or area of contact of the tire tread with a flat surface at zero speed and under normal load and pressure.

[0013] "Peristaltic" means operating by means of wave-like contractions that propel contained matter, such as air, along tubular pathways.

[0014] "Radial" and "radially" means directions radially toward or away from the axis of rotation of the tire.

Brief Description of the Drawings

[0015] The invention will be described by way of example and with reference to the accompanying drawings in which:

FIG. 1 is a perspective view of the tire system showing pump location (1st embodiment).

FIG. 2A is a perspective cut away of the tire showing (2) part pump before assembly, and the phantom box shown to illustrate the glue area on inner wall. FIG. 2B is a perspective cut away of tire showing (2) part pump assembled with tube inserted through tire wall.

FIG. 3A is a side view showing pump location in non-compressed area of tire.

FIG. 3B is a side view showing pump location in a

compressed area of tire.

FIG. 4 is a sectioned view taken from 4-4 of FIG.3A.

FIG. 5 is a sectioned view taken from 5-5 of FIG.3B.

FIG. 6A is an enlarged view of the pump showing piston locations at rest

FIG. 6B is an enlarged view of the pump showing viscoelastic material moving the upper piston downward and compressing air between the pistons.

FIG. 6C is an enlarged view of the pump showing the upper and lower pistons moving and releasing compressed air into tire cavity.

FIG. 6D is an enlarged view of the pump showing the pistons at rest and the relief valve releasing cavity over pressure to atmosphere.

FIG. 7 is an exploded cross section of the pump body.

FIG. 8 is a perspective view of a tire showing the pump location in a second embodiment.

FIG. 9A is a perspective view of exploded 2-part pump of the second embodiment.

FIG. 9B is a perspective view of the assembled pump.

FIG. 10A is a side view showing pump location in non-compressed area of a tire.

FIG. 10B is a side view showing pump location in a compressed area of tire.

FIG. 11A is a sectioned view taken from 11A-11A of FIG.10A.

FIG. 11B is an enlarged view of the pump taken from FIG.11A.

FIG. 12A is a sectioned view taken from 12A-12A of FIG.10B.

FIG. 12B is an enlarged view of the pump taken from FIG.12A.

FIG. 13A is a sectioned view taken from 13A-13A of FIG.11B with the pump shown at rest.

FIG. 13B is a sectioned view taken from 13B-13B of FIG. 12B, with viscoelastic material filling the chamber and pushing air through a second one-way valve into the tire cavity.

FIG. 13C is a sectioned view showing viscoelastic material returning to the upper housing and pulling outside air through the first one-way valve and filling the inner chamber.

FIG. 13D is a sectioned view showing the relief valve releasing cavity over pressure to the atmosphere.

FIG. 14A is a perspective view of the pump body insert.

FIG. 14B is a perspective cross section view of the pump body insert.

FIG. 14C is a perspective exploded cross section view of the pump body insert.

FIG 15 is a sectioned view showing a modified version of a piston pump and compression actuator assembly attached to a tire inner liner.

FIG. 16 is a bottom perspective view of the piston pump assembly.

FIG. 17A is an enlarged section view of the piston pump taken from FIG. 16 showing the pump at rest

with outside air entering the inlet chamber.

FIG. 17 B is a view subsequent to FIG. 17A, showing viscoelastic material filling the pump housing chamber and pushing the piston valve member inward and sealing off the inlet, and the pressurized air forcing the valve member downward to open the outlet and release air to cavity.

FIG. 18A is a sectioned isometric view of the pump assembly shown in FIG. 17A.

FIG. 18B is an exploded view of FIG. 18A.

FIG. 19A is a schematic view of a rolling tire showing sequential positionment of the pumping assembly as the tire rotates.

FIG. 19B is a diagrammatic view showing the pump operation at the sequential positions of FIG 19A.

FIG. 20 is a graph of pumping air pressure over a time interval as a tire rotates.

Detailed Description of the Invention

[0016] Referring to FIGS. 1, 2A, 2B, 3A, 3B, and 4, the subject Self-Inflating Tire System 10 is shown to include a tire carcass of generally conventional construction having a pair of sidewalls 14, a pair of beads 16, and a tread 18. The tire 12 is configured to be self-inflating by inclusion of a pump assembly 20 and coupled compression actuator assembly 19, both of which being attached to the tire in a post-cure assembly procedure. As shown in FIG. 2A, the assembly 19 may be mounted to a sidewall 14 by application of adhesive as shown in phantom as adhesive area 21. The tire 12 mounts conventionally to a rim 22 having a tire mounting surface 26 and an outer rim flange 24 extending from surface 26. The tire 12 is further formed to provide an inner liner component 28 which defines and encloses an internal tire air cavity 30. Adhesive is applied to the sidewall region of the inner liner 28 as depicted by area 21. The tire 12 is formed to further provide a lower sidewall region 32 proximate to the bead areas 16 of the tire.

[0017] The tire assembly 10 mounts to a vehicle and engages a ground surface 34. Contact area between the tire 12 and the ground surface 34 represents the tire footprint 38. The compression actuator assembly 19 mounts to a sidewall region 42 of the tire 12 having a relatively high flex-deformation as the tire rotates in direction 40 against ground surface 34 as shown in FIGS. 3A and 3B. As the tire rotates, the compression actuator assembly 19 and pump assembly 20 will rotate with the tire. The compression actuator assembly 19 will be subjected to compression forces resulting from the sidewall flexing or bending when the assembly 19 is opposite the tire footprint 38 for a purpose explained below. FIG. 3A and section view FIG. 4 show the compression actuator assembly 19 and pump assembly 20 location in a non-compressed area of the tire 12 while FIG. 3B and section view FIG. 5 show the assemblies 19 and 20 in a compressed area of the tire 12. In the position of FIG. 5, the compression actuator assembly 19 will be subjected to

the compression forces 36 generated within tire footprint 38. The tire rotates in direction 40 and in the opposite direction during normal operation of a vehicle. As such, the coupled assemblies 19, 20 rotate with the tire in both directions and are subjected to compression forces generated within the sidewall 14 in both forward and reverse tire rotational directions.

[0018] In reference to FIGS. 2A, 2B, 4, 5, 6A, 6B, 6C, 6D, and FIG. 7, the compression actuator assembly 19 includes an elongate hollow containment body 44 formed from a resilient deformable material composition such as thermoplastic resin and/or rubber compound. The body 44 so composed is thus capable of reciprocally and resiliently undergoing a cyclic deformation into a deformed state and recovery into an original non-deformed state when subjected to bending force. The elongate body 44 as shown in FIG. 2A, 4, is sized and shaped to generally follow the inner contour of the tire sidewall 14 from the tread region 18 to the bead area 16. The hollow, elongate form of the containment body 44 may be affixed to the inner liner 28 of the tire at adhesive region 21 or modified in form for incorporation into the tire sidewall as will be explained.

[0019] The containment body 44 includes an enclosed central reservoir cavity 46 filled with a volume of non-compressible medium 48. The medium may be in either foam or fluid form. Medium suitable for use in the subject application may include, but is not limited to water with an antifreeze additive. The medium 48 is enclosed by the body 44 within the cavity 46 and generally fills the cavity 46. An outlet conduit 50 is provided to the body 44, the conduit 50 extending generally axially from the body 44 and containing an inner outlet conduit bore 51 through which a displaced quantity of medium 48 may travel in reciprocal directions. The conduit 50 extends to a leading end surface 60.

[0020] Positioned as shown in FIGS. 2A, 2B, 4, 5, the containment body 44 is subjected to bending forces from the tire sidewall 14 as the region of the sidewall to which body 44 attaches passes proximate to the tire footprint and is compressed by forces 36 on the tread 18 (FIGS. 3B, 5). Bending forces 36 applied to bend the sidewall region 14 serve to cause a commensurate bending deformation 52 of the medium containment body 44 as shown in FIGS. 6A, 6B, 6C and 6D. The deformation 52 introduced into the body 44 by bending tire sidewall 14 proximate to the tire footprint 38 causes displacement of a quantity 54 of the medium 48 along the outlet conduit 50 in the direction shown at arrow 56 of FIG. 6B. Pressure from the displaced medium quantity 54 acts as a pressure actuator to the pumping assembly 20 as will be explained. When the tire sidewall region to which body 44 attaches leaves a proximal position to the tire footprint 38, such as the position opposite the tire footprint as depicted in FIG. 6A, the compression force in the sidewall is removed/lessened, causing a commensurate removal/lessening of bending force into the containment body 44. Removal of bending force in the containment body 44

causes the body 44 to resume its original, non-deformed state as shown in FIG. 4 and the medium 48 to recede within the conduit 50 in direction indicated at arrow 58. The cycle of sidewall bending and unbending translates into a cyclic deformation, restoration of the containment body 44 as the tire rotates in either a forward or reverse direction and generates a cyclic compression force from displaced medium volume 54 along the conduit 50. The compression force from the displaced medium quantity 54 is in the direction 56 and is proportionate to the pressure generated by the displaced quantity of the non-compressible medium 48.

[0021] Referring to FIGS. 6A through D and 7, the pump assembly 20 is affixed to the tire carcass 12 at a location adjacent the compression actuating assembly 19, preferably in an inward radial direction relative to assembly 19. The pumping assembly 20 includes a hollow compressor body 62 of generally tubular form having an internal axially oriented air chamber 64 which extends to a lower chamber end 65. The air chamber 64 is accessible through an inlet conduit 66 which intersects the air chamber 64 at an inlet opening 67. The body 62 and conduit 66 are formed of a rigid material such as metal or plastic. Conduit 66 is generally elongate and tubular having an internal axial passageway 68 communicating with the air chamber 64 via opening 67. On the opposite side of the body 62 an outlet conduit 70 of generally tubular form having an axial passageway 72 extending there through and communicating with the air chamber 64 at outlet opening 73. The inlet conduit 66 and the outlet conduit 70 are axially offset, with conduit 66 closest to the actuating assembly 19 and conduit 70 farthest away from assembly 19.

[0022] A first cylindrical piston member 74 is sized for sliding position within an upper end of the axial air chamber 64 of the compressor body 62 and includes a blind axial bore 76 extending into an inward piston end surface 75. A recess 78 extends through an outward facing piston side and functions as a collector for the air which will come out of the valve (assembly 96). It will connect the valve and the canal inside the piston whatever is the angular position of the piston. Extending into a piston side opposite the recess 78 is a relief valve intake channel 80 that communicates with the blind bore 76.

[0023] A second cylindrical piston member 82 is sized for sliding receipt within a lower end of the axial air chamber 64 of the compressor body 62. The second piston 82 includes a cylindrical body 84 and an outward spring-compressing post arm 86 extending from the body 84 to an outward end 85. A blind bore 88 extends into the end surface 85 of the post arm. A transversely oriented inlet channel 90 extends through a side of the post arm 86 to communicate with the blind bore 88. A large coil spring 94 is provided sized to fit within the lower end 65 of the air chamber 64 within the compressor body 62. A smaller coil spring 92 is further provided and seats against surface 77 within the blind bore 76 of the first piston 74. A pressure regulating relief valve assembly 96 mounts

within an inlet chamber 99 of an inlet tubular sleeve 98 extending from the compressor body 62. The sleeve 98 includes an inlet axial passageway 97 extending from the chamber 99 to the air channel 64 of the compressor body 62. The assembly 86 includes a circular body 100 having a tubular entry conduit 102 extending outward. A through bore 104 extends through the conduit 102 and body 100. A disk-shaped seal component 106 is positioned within the chamber 99 inward of the circular body 100 and is outwardly biased against the circular body 100 by a coil spring 108 seated within the chamber 99.

[0024] At the opposite side of the compressor body and affixed to the inlet conduit 66 is an inlet tube 110 having an annular abutment flange 112 at an inward end and an axial passageway 114 extending from an outward tube end 115 through the tube 110 to the inlet opening 67 of the compressor body 62. Seated within the tube passageway 114 proximate the outward tube end 115 is a porous filter component 116 that functions to filter out particulates from entering the tube passageway 114. The pumping assembly 20 is enclosed within an outer sheath or casement 128 that is shaped to complement a radially lower region of the sidewall 14 and extends from the compression actuating body 44 to a location opposite to a tire bead region. The casement 128 is formed from a protective material that is suitable for attachment to the tire innerliner by adhesive such as a rubber matrix.

[0025] With respect to FIGS. 4, 5, 6A, and 7, the compression actuation assembly 19 and the pump assembly 20 are connected together as shown for incorporation into the tire carcass 12. The actuation assembly 19 is incorporated into a region of the sidewall 14 of the tire carcass 12 that experiences a high bending load as the tire rotates. The assembly 19 may either be incorporated within the sidewall 14 or affixed to the sidewall 14 by adhesive as shown. In the externally mounted assembly approach shown, the containment body 44 is complementarily shaped and curved as the sidewall region to which it attaches and extends generally from a radially outward end 130 proximate the tread region 18 radially inward along the sidewall attachment region to a radially inward end 132 proximate a bead region. The pumping assembly 20 attaches to the inward end 132 of the assembly 19 by adhesive or other suitable attachment means. The pumping assembly 20 is sheathed within an outer casing 128 composed of a tire compatible material such as rubber. The coupled compression actuation assembly 19 and pumping assembly 20 mount by adhesive attachment to the inner liner 28 of the tire carcass 12 with the assembly 20 proximate to the carcass bead/lower sidewall region 32. So positioned, the inlet tube 110 to the assembly 20 projects in an axial direction through the tire sidewall 14 to an external air-accessible outer tire sidewall side location. Positionment of the tube 110 is preferred above the rim flange 24 so that the rim flange 24 will not interfere with intake air entering the tube 110 of the pumping assembly 20.

[0026] As will be appreciated, the outlet conduit 50 of

the compression assembly 19 couples into the upper end of the compressor body 62 as the outlet conduit 50 of actuator body 44 is received in sealing engagement with the upper end of the compressor body 62. The compressor body 44 abuts against the casing 128 containing the pumping assembly 20. Once the assemblies 19 and 20 are attached together, they may be attached to a region of the tire sidewall 14 as shown in FIGS. 2A and 4 and described previously. The first and second pistons 74, 82 are mechanically coupled as the post projection 86 from the second piston 82 projects into the bore 76 and against the spring 92 seated within bore 76. Axial movement of the pistons 74, 82 are thus synchronous within the air chamber 44 in both radial directions.

[0027] FIGS. 6A through D depict the operation in sequence of the pump assembly 20 and compression actuator assembly 19. FIG. 6A shows the pump assembly 20 with the pistons 74, 82 in the at rest positions. The position shown correlates with a position of the assemblies 19, 20 mounted to a rolling tire as shown in FIG. 3A at a rotational position opposite to the tire footprint. The sidewall 14 area supporting assemblies 19, 20 when opposite the tire footprint (FIG. 6A) is not flexed or bent from the tire contact with ground surface. Accordingly, the compression actuator body 44 has a bending deformation 52 that generally correlates with the curvature of the unbent sidewall 14. The medium 48 enclosed within the body 44 is generally at rest and contacts the leading medium surface 60 within conduit 50 against the end of piston 74. The outer piston 74 is retracted toward the outer end of the air chamber 64 under spring bias from coil spring 92.

[0028] In the "at rest" position of FIG. 6A, the piston 74 is axially above the intake opening 67 if the inlet conduit 66. As a result, air from outside of the tire is admitted through the filter 116 and into the bore 114 of the inlet conduit 110 from which it channels through the opening 67 of the inlet conduit 66 and into the air chamber 64. Arrows 118 show the path of inlet air travel. The piston 82 is in an axially raised position within the body air chamber 64 and blocks off the outlet opening 73 of the outlet conduit 70. Springs 92, 94 are in respective uncompressed conditions. The relief valve assembly 96 is generally in a closed position so long as the pressure within the tire cavity remains below a preset recommended inflation pressure. In the closed position, the spring 108 biases the stop disk head 106 against the opening 102 through conduit body 100. Should the pressure within the tire cavity exceed a pressure threshold, the air pressure from the cavity will force the stop 106 away from the conduit opening 102 and allow air to escape from the tire cavity.

[0029] As the region of the sidewall 14 carrying the assemblies 19, 20 rotates into opposition to the tire footprint, the sidewall 14 flexes and bends, causing a commensurate flexing of the compression actuator body 44 as shown at numeral 52 of FIG. 6B. FIG. 6B shows that the viscoelastic material 48, having non-compressible

material properties, in response to the bending of body 44 is forced lower within the outlet conduit 50 and exerts a downward pressure on the first piston 74 as indicated by arrow 56. The leading end surface 60 of the medium 48 bears against the outward surface of the piston 74 and overcomes the resistance of coil spring 92 by compression of spring 92 to allow piston 74 to move lower into the air chamber 64. In so doing, the piston 74 moves into a position blocking air intake into the chamber 64 through the intake tube 110 and compresses the volume of air within the chamber 64. Increased pressure of air within the chamber 64 forces the second piston 82 lower within the air chamber 64 and compresses the coil spring 94.

[0030] When the piston 82 has moved a sufficient axial distance within the air chamber 64, the outlet opening 73 into the outlet conduit channel 72 ceases to be obstructed by the piston 82 as shown in FIG. 6C and FIG. 5 Pressurized air from the chamber 64 is thus forced through the channel 72 and into the tire cavity in the direction indicated by arrow 126. When the pumping of air is complete and pressure within chamber 64 against the second piston 82 is discontinued, the piston 82 is forced axially upward and back into the at-rest position shown both in FIG. 6D and FIG. 6A.

[0031] As seen from FIG. 6D, once removal of the quantity of pressurized air within the chamber 44 into the tire cavity is complete, with further rotation of the tire the assemblies 19, 20 with the attachment region of sidewall 14 leave the high stress position opposite the tire footprint and the tire sidewall region resumes an unstressed curvature as shown in FIG. 2A and 3A. The return of the sidewall 14 to an original curvature configuration outside of the tire footprint is accompanied by and synchronous with a return of the actuator body 44 to an unbent configuration. As the actuator body 44 resumes its original curvature, and commensurate with the end of the pumping cycle of air from air chamber 64, piston 82 moves axially upward under the influence of spring 94 which forces the piston 74 in a radial upward movement. The viscoelastic medium 48 recedes into the original containment form of the body 44 and the pumping of air into the tire cavity is discontinued until the assemblies 19, 20 rotate with the tire back into alignment opposite the tire footprint. With each revolution, the pumping of air from chamber 64 into the tire cavity occurs in cyclic fashion. It will be appreciated that the operation of the air pumping action is independent of the direction of tire revolution and will occur in either a forward or reverse tire travel.

[0032] FIG. 6D also depicts view of the pump assembly 20 wherein pistons 74, 82 are in the at-rest position while the relief valve assembly 96 functions to vent tire cavity over-pressure air to the atmosphere. The relief valve assembly 96 is generally in the closed position shown in FIGS. 6A through 6C and only opens when the air pressure within the tire cavity exceeds a recommended upper threshold. In such an event, the stop body 106 is forced laterally out of sealing engagement against with conduit

flange 100 and overcoming biased resistance from the coil spring 108. The passageway 104 is thus opened to allow over-pressure air from the tire cavity through the conduit 102 and the relief channel 80 within piston 74 as indicated by directional arrow 124. The pressurized air follows a path through the blind bore 76 of piston 74, through the blind bore 88 within the coupling post 86 of piston 82, and into the bore 114 of tube 110 as indicated by directional arrow 122. The expelled over-pressure air exhausts to the atmosphere through filter unit 116 and out of tube end 115. The exhaust of air through filter 116 operates to clean particulates from the filter as well as correcting the over-pressure within the tire cavity. Once the tire cavity pressure is reduced below the threshold recommended pressure, spring 108 will uncoil and pressure the stop body 106 against the conduit flange end 100 and thus close off the tire cavity until over-pressure exhausting of air from the tire cavity is necessary.

[0033] Referring to FIGS. 9A, 9B, 10A, 10B, 11A, 11B, 12A, 12B, 13A through 13D, 14A through 14C, inclusive, an alternative embodiment of a pump and compression actuating assembly 134 is shown including a compression actuating assembly 136 coupled to a pump assembly 138 to form an L-shaped insert body 140. The body 140 mounts to a lower sidewall region of a tire carcass 12 proximate to a bead region 16 as shown in FIGS. 10A, 10B. The compression actuating assembly 136 has a deformable hollow body 142 forming a containment chamber 144 communicating with an outlet portal 146. The hollow body 142 is configured at ninety degrees into an L-shape having upright body portion 148 extending from horizontal body portion 150. A viscoelastic medium on non-compressible material 152 fills the containment chamber 144 as previously described in reference to the first embodiment.

[0034] The pump assembly 138 likewise forms an L-shaped encapsulation sheath body 154 affixed to the L-shaped compression actuating body 142. Body 154 includes an upright body portion 158 extending from horizontal body portion 156. An outlet orifice 160 is positioned within the horizontal portion 156 and an inlet orifice 162 in a side facing region of the portion 156. An outlet conduit 168 is attached to the outlet orifice 160 and includes an axial passage 170 extending to a remote end 170.

[0035] FIGS. 10A and 10B show the mounting of the L-shaped pump assembly 134 to a tire at a lower sidewall region proximate to a tire bead location. As with the embodiment previously described, the pump assembly 134 rotates with the tire from a location outside of proximity to the tire footprint (FIG. 10A) into a position opposite the tire footprint (FIG. 10B) with each tire revolution. As with the first embodiment, the assembly 134 body 140 is bent by stress induced from a bending of the tire sidewall as the rotational position of assembly aligns opposite the tire footprint (FIG. 10B). FIGS. 11A and 11B show the relative position of the assembly 134 within the lower region of sidewall 14 where the assembly body 140 is subjected to high bending forces as the tire rotates. The

outlet end 172 of the outlet conduit 168 extends through the tire wall to the cavity 30 of the tire. Compressed air from the compressor body 174 travels along passage 170 and into the tire cavity to keep the inflation pressure of the tire at a desired level.

[0036] FIG. 11A is a sectioned view taken from a pump location in a non-compressed area of the tire as shown in FIG. 10A. FIG. 11B is an enlarged view of the pump assembly 134 of FIG. 11A. FIG. 12A is a sectioned view taken from a pump location in a compressed area of the tire as shown in FIG. 10B. FIG. 12B is an enlarged view of the pump assembly 134 as depicted in FIG. 12.

[0037] With reference to FIGS. 13A through 13D and 14A through 14C, the compression body 174 has an internal elongate compression chamber 176 and a pair of one-way ball valves 178, 180 positioned at opposite ends of the chamber 176. Each of the valves 178, 180 is of a type commercially available and each includes a stop ball component 182 biased by a coil spring against a seat 186. In addition, a relief pressure by-pass passage 188 is provided within the compression body 174 in parallel to the chamber 176. Seated within the passage 188 is a one-way ball valve 190 of similar configuration as the ball valves 178, 180. The passageway 188 and the chamber 176 extend in parallel between the outlet conduit 168 at one end of the body 174 and the inlet opening 162 at an opposite end.

[0038] Operation of the first alternative form of the pumping assembly 138 proceeds as follows. The L-shaped body 136 is embedded or affixed to the tire carcass in the position shown generally by FIGS. 10A and 10B. So positioned, as the tire sidewall to which the assembly 138 undergoes bending, the compression actuating body 142 will likewise undergo bending. FIGS. 13A and 13D show the pump assembly 138 in an "at-rest" status; that is, with the assembly 138 not under bending stress as the tire position of FIG. 10A represents. The ball valves 178, 180 are in a seated closed position. The valves 178, 180 are selected to open at a desired threshold pressure as will be explained.

[0039] In the at-rest position, air within the compression chamber 176 is unpressurized. The relief valve 190 is likewise seated and closed and will remain so unless the air pressure within the tire cavity 30 is over a desired pressure threshold. In an over-pressure situation, the valve 190 will open and allow air to escape the cavity 30 through passage 188 and exhausted from the inlet opening 162 to the atmosphere. The compression medium 152 is confined to the compression body chamber 176 and the inlet conduit 164 is clear.

[0040] FIG. 13B and FIG. 12B show the pump assembly 134 when the tire has rotated the assembly into a position opposite the tire footprint (FIG. 10B). The compression body 174 is then subjected to a bending force and is deformed. The bending of the body 174 forces the viscoelastic material 152 from the chamber 144 into and along the conduit 164 (direction 192) which, in turn, acts to compress air within the compression chamber 176.

Pressure from the compressed air opens the valve 180 by unseating valve ball 182 and air is channeled into the outlet conduit 168 to the tire cavity 30.

[0041] FIG. 13C represents the pump assembly 134 after further rotation of the tire occurs, positioning the pump assembly away from the tire footprint such as the position shown in FIG. 10A. The removal of bending force to the body 174 allows the resilient body to return to its original configuration and chamber 176 into a form allowing the medium 152 to recede back from the conduit 164. The transfer of pressurized air from the chamber 176 draws air into the chamber 176 from the atmosphere through the unseating of one-way valve 178 from its seat 186. Air drawn into the chamber 176 forces the medium 152 back into the chamber 144 as shown at arrow 194. Valve 180 has reseated itself and blocks off air from exiting the chamber 176. A filter member 198 within the inlet end of the chamber 176 keeps particulates from entering the chamber 176.

[0042] FIG. 14D shows the assembly 134 back into its original at-rest position. In the event that an over-pressure situation arises within the tire cavity, the tire air pressure will cause the one-way valve 190 to open and air to flow in direction 196 back through the passage 188 for exhaust through filter 198 and into the atmosphere. The back flow of air through filter 198 helps to keep the filter clean. As with the first embodiment, the pump assembly 134 operates in either direction of tire rotation and pumps air into the tire during each cycle of tire revolution.

[0043] With reference to FIGS. 17A, B, 18A and B, a tank-based hydraulic pump assembly 200 is shown in a commercially viable configuration. The assembly 200 is functionally analogous to the embodiment of FIGS. 4 and 7 as previously discussed. Assembly 200 includes an air compressor body 202 having an elongate axial bore or chamber 204. The chamber 204 is subdivided into a rearwardly located piston chamber 206 at a rearward end 208 of the body 202. End 208 of the body 202 has external screw threads 210 for assembly purposes. Adjacent to the rearward piston chamber 206 is a medial air compression chamber 212. Positioned at the chamber 212 is a tubular inlet air channel 214 extending through a sidewall of the body 202 into communication with chamber 212. An external inlet sleeve 216 is an extension of the body 202 opposite the channel 214 and encloses a throughbore 218. Assembly screw threads 220 are positioned within the bore 218.

[0044] Separating chambers 206 and 212 along the bore 204 is an annular piston stop flange 222. Adjacent to the chamber 212 at an opposite end along the bore 204 is an outlet chamber 224. A tubular outlet sleeve 226 affixes to the body 202 opposite the outlet chamber 224 and contains a throughbore 228 and internal assembly screw threads 230. Separating chambers 224 and 212 is an annular stop flange 232. A head cap member 234 having an axial internal chamber 236 attaches to end 208 of the body 202. The cap member 234 includes an outer flange 238 and an annular detent channel 237 adjacent

cap flange 238. The cap member 234 has a cylindrical body portion 240 that is internally threaded by screw threads 242. Extending through a sidewall of the cap member 234 is a fill conduit 244 having a throughbore 246 and internal screw threads 248. A screw member 250 includes threads 252 that thread into the fill conduit 244.

[0045] An inlet conduit 254 has a cylindrical body 256 and a threaded end 258 that threads into the inlet sleeve 216. An enlarged head 260 is integrally joined to body 256 and a throughbore 262 extends axially through the inlet conduit 254 end to end. An end cap member 264 affixes to end 263 of the body 202 and includes internal screw threads 266 and an end wall 268. A central aperture 270 extends through the wall 268. A coil spring 272 seats within the cap member 264 against the wall 268. A cylindrical valve member 274 is positioned within the outlet chamber 224 of the axial bore 204 of body 202 against the coil spring 272. So situated, the valve member 274 slides axially within the chamber 224 in forward and reverse directions as will be explained.

[0046] A piston valve member 280 is positioned within the piston chamber 206 of the axial bore 204 of body 202. The member 280 has an enlarged circular head 282 and an annular spring retention groove 283 extending into an underside of the head 282. The member 280 further includes an elongate cylindrical body 284 extending to a forward end 286. The cylindrical body 284 is sized for insertion within the coil spring 278 with an outward end of the spring 278 seated within retention groove 283. Situated within the chamber 206, the forward end 286 of the body 284 projects forward and closely resides within the air compression chamber 212 of the axial bore 204 of body 202 as seen in FIG. 17A and 17B. The outer surface 288 of the head 282 of piston valve 280 aligns along the axial bore 204 of body 202 and with the internal axial chamber 236 of the head component 282 attached to the body 202. An outlet conduit 290 attaches by screw threads 292 into the outlet sleeve 226 and aligns a throughbore 294 with the sleeve bore 228. The conduit 290 creates an air passage extending from the outlet chamber 224 to the tire cavity when the pump assembly is mounted as intended to a tire.

[0047] As with the previously discussed embodiment of FIGS. 2A and 7, the tank-based pump assembly 200 as shown in FIGS. 17A and 17B attaches to an actuator tank or compression actuating body 296 having a forward coupling rib 298 which engages into the detent channel 239 of the head cap component 234. The compression actuating body 296 contains an internal reservoir 300 of a non-compressible medium 302 such as an anti-freeze and water mix. The outlet of the body 296 thus is in medium fluid-flow communication with the internal chamber 236 of the head component 282 and the outer surface 288 of the piston valve 280 situated within the chamber 206.

[0048] FIGS. 15, 17A, 17B, 18A illustrate the pump assembly 200 in the assembled condition with the inlet

tube 254 screw assembled into the inlet sleeve 216 of body 202; cap member 264 screw assembled over end 263 of body 202; outlet conduit 290 screw assembled into outlet sleeve 226 of body 202; head cap member 234 screw assembled over end 208 of body 202; and the screw member 250 screw assembled into fill port 244. The compression actuating body or tank 296 is attached to the rearward end of the head cap and filled with medium 302 via fill port 244 with the screw member 250 removed. Screw member 250 is removed and, subsequent to medium fill, reinserted into the fill port 244 to encapsulate the medium within the reservoir 300. In containment, the medium fills the head cap member chamber 236 and abuts against surface 288 of the piston valve 280.

[0049] The assembly 200 with the compression actuating body 296 is affixed to the inner liner 28 of a tire as shown in FIG. 15. The inlet tube 254 extends through the tire sidewall and presents the outer end of throughbore 262 to the external atmosphere. The outlet conduit 290 extends from the pump assembly into the tire cavity to direct replenishment air into the cavity as required.

[0050] FIG. 17A shows the pump assembly 200 in an at-rest condition, with outside air entering the inlet chamber. The piston valve 280 is at a rearward location within the piston chamber 206 and the coil spring 278 is in a relaxed extended condition. So positioned, the piston valve 280 does not block the inlet of air from throughbore 262 of the inlet tube 254 into the compression chamber 212 as indicated at arrow 303. In the at-rest position of FIG. 17A, the valve member 274 is positioned by coil spring 272 at a location blocking the flow of air from the compression chamber 212 into the outlet conduit 290. In the at-rest condition, accordingly, the pump assembly 200 is not pumping air into the tire cavity.

[0051] FIG. 17 B is a view subsequent to FIG. 17A, wherein a deformation of the compression actuating body 296 acts to pressure the viscoelastic material medium 302 through the cap member chamber and against surface 288 of the piston valve, and moves the piston valve forward as indicated by arrow 304. Forward movement of the piston valve 280 compresses spring 278 and positions the piston valve in a position blocking the entry of air from throughbore 262 of the inlet tube 254 into the compression chamber 212. The forward movement of piston valve 280 further acts to compress the air volume within compression chamber 212 which, in turn, moves the valve member 274 outward toward the surface 268 and compresses spring 272. Any air trapped in behind the valve member 274 is vented through aperture 270. The movement of the valve member 274 further acts to open the outlet from outlet chamber 224 into the outlet bore 294 of outlet conduit 290, whereby allowing pressurized air from the chamber 212 to be routed through the conduit 290 into the tire cavity as indicated by arrows 305. When the air pressure within the compression chamber 212 has diminished, the spring 272 uncoils and forces the valve member 274 back into the position of

FIG. 17A. Likewise, the return of the compression actuating body 296 into its underformed configuration reduces pressure on the piston valve 280. Spring 278 thus uncoils and forces the piston valve into the position of FIG. 17A.

[0052] FIGS. 17A, 17B, 19A and 19B show the operational cycle of the pump assembly 200 as a tire rotates against a road surface. The flexing of the tire sidewall causes a deformation of the compression actuating body 286 as the body 286 enters a position opposite the tire footprint. T1-T0 show the position of the pump entering and leaving the footprint vicinity. FIG. 19B shows the operation/location of the piston valve 280 and valve member 274 at each of the stages T1-T0. The pump assembly 200 accordingly cyclically alternatively closes and opens inlet and outlet ports to effect pressurized air replenishment of the tire during rotational operation of the tire. FIG. 20 shows in graphic form cyclical pressure level variance within the air compression chamber over time.

Claims

1. A tire system comprising:

a tire (12) having a tire carcass comprising a tire cavity defined by a tire inner liner (28), and first and second sidewalls (14) extending respectively from first and second tire bead regions (16) to a tire tread region (18);

compression actuator means (19) mounted to the tire carcass configured for operative actuation by tire deformation during a tire revolution; and

a pump assembly (20) affixed to the tire carcass and comprising a compressor body (62) affixed to the compression actuator means and having an internal air chamber (64), the internal air chamber having an inlet opening (66) for admitting air into the internal air chamber and an outlet opening (70) for conducting air from the internal air chamber to the tire cavity, the compressor body (62) further comprising a piston valve member (74) operationally moving within the internal air chamber responsive to actuation by or contacting engagement with the compression actuator means (19) to compress air within the internal air chamber (64).

2. The tire system of claim 1, wherein the piston valve member (74) is located within the internal air chamber (64) and operationally moves within the internal air chamber responsive to a contacting engagement with or an actuation by the compression actuator means (19) between an open position relative to the inlet opening (66) permitting air flow from the inlet opening into the air chamber and a closed position relative to the inlet opening obstructing air flow from

the inlet opening into the air chamber, the piston valve member (74) during operational movement between the open and closed positions compressing a volume of air within the air chamber (64).

5

3. The tire system of claim 1 or 2, further comprising an outlet valve member within the air chamber and for operationally moving along the air chamber responsive to air pressure within the air chamber reaching a preset threshold between an open position permitting air flow from the air chamber into the outlet opening and a closed position obstructing air flow from the air chamber into the outlet opening.

10

4. The tire system of claim 3, wherein the piston valve member (74) and the outlet valve member are positioned at opposite ends of the air chamber.

15

5. The tire system of at least one of the previous claims, in particular of claim 4, further comprising an inlet conduit extending through the tire between the inlet opening and an outward facing side of the tire.

20

6. The tire system of at least one of the previous claims, in particular of claim 5, further comprising an outlet conduit extending from the outlet opening to the tire cavity.

25

7. The tire system of at least one of the previous claims, wherein the air compressor body comprises an outlet valve member located within and at opposite respective ends of the internal air chamber, the piston valve member (74) and the outlet valve member operationally moving within the internal air chamber responsive to actuation by the compression actuator means between respective open and closed positions, whereby cyclically opening and closing the inlet and the outlet openings during an air compression cycle comprising air intake, air compression, and air discharge within the air chamber.

30

35

40

8. The tire system of at least one of the previous claims, in particular of claim 7, wherein the piston valve member (74) in the open position relative to the inlet opening permits air flow from the inlet opening into the air chamber and the piston valve member (74) in the closed position relative to the inlet opening obstructs air flow from the inlet opening into the air chamber, and wherein the piston valve member (74) during movement between the open and closed positions operationally compresses a volume of air within the air chamber.

45

50

9. The tire system of at least one of the previous claims, wherein the outlet valve member in the closed position relative to the outlet opening is operative to move to the open position responsive to air pressure within the air chamber reaching a preset threshold wherein

55

permitting air flow from the air chamber into the outlet opening.

10. The tire system of at least one of the previous claims, in particular of claim 5 or 9, wherein the compression actuator means comprises a hollow containment body formed from a resilient deformable material composition and containing a quantity of a non-compressible medium, wherein the containment body is affixed to a relatively high flex-deformation region of the tire carcass and the containment body operationally reciprocally transforms between a deformed state and a non-deformed state responsive to deformation and recovery of the tire high flex-deformation region in a rolling tire, respectively; and wherein the actuator means containment body in the deformed state operationally displaces a pressurized displaced quantity of the non-compressible medium, the pressurized displaced quantity of the non-compressible medium operationally generating a compression force against a piston valve member surface to move the piston valve member (74) between the open and closed positions within the air chamber.
11. The tire system of at least one of the previous claims, wherein the containment body operationally undergoes a cyclic transformation between the deformed state and the non-deformed state during a tire revolution against a ground surface.
12. The tire system of at least one of the previous claims, wherein the outlet valve member comprises a plug member operationally fitting within the outlet opening in the closed outlet valve member position and the plug member operationally dislodges from within the outlet opening in the open outlet valve member position.
13. A method of maintaining air in a tire, the method comprising:
- providing a tire (12) having a tire carcass comprising a tire cavity defined by a tire inner liner (28), and first and second sidewalls (14) extending respectively from first and second tire bead regions (16) to a tire tread region (18);
- providing compression actuator means (19) mounted to the tire carcass configured for operative actuation by tire deformation during a tire revolution; and
- providing a pump assembly (20) affixed to the tire carcass and comprising a compressor body (62) affixed to the compression actuator means and having an internal air chamber (64), the internal air chamber having an inlet opening (66) for admitting air into the internal air chamber and an outlet opening (70) for conducting air from the internal air chamber to the tire cavity, the

compressor body (62) further comprising a piston valve member (74) operationally moving within the internal air chamber responsive to actuation by or contacting engagement with the compression actuator means (19) to compress air within the internal air chamber (64).

14. The method of claim 13, wherein the piston valve member (74) moves within the internal air chamber responsive to an actuation by or a contacting engagement with the compression actuator means (19) between an open position relative to the inlet opening (66) permitting air flow from the inlet opening into the air chamber and a closed position relative to the inlet opening obstructing air flow from the inlet opening into the air chamber, and wherein the piston valve member (74) during movement between the open and closed positions compresses a volume of air within the air chamber (64).

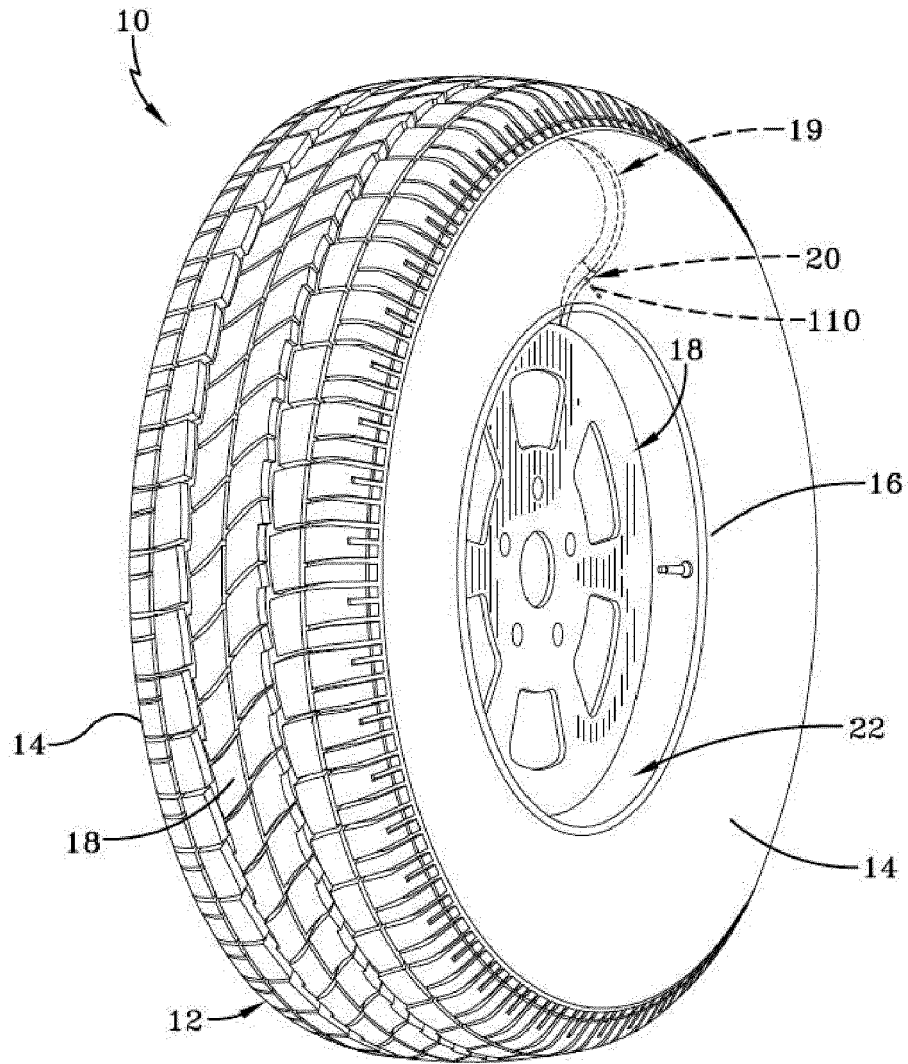
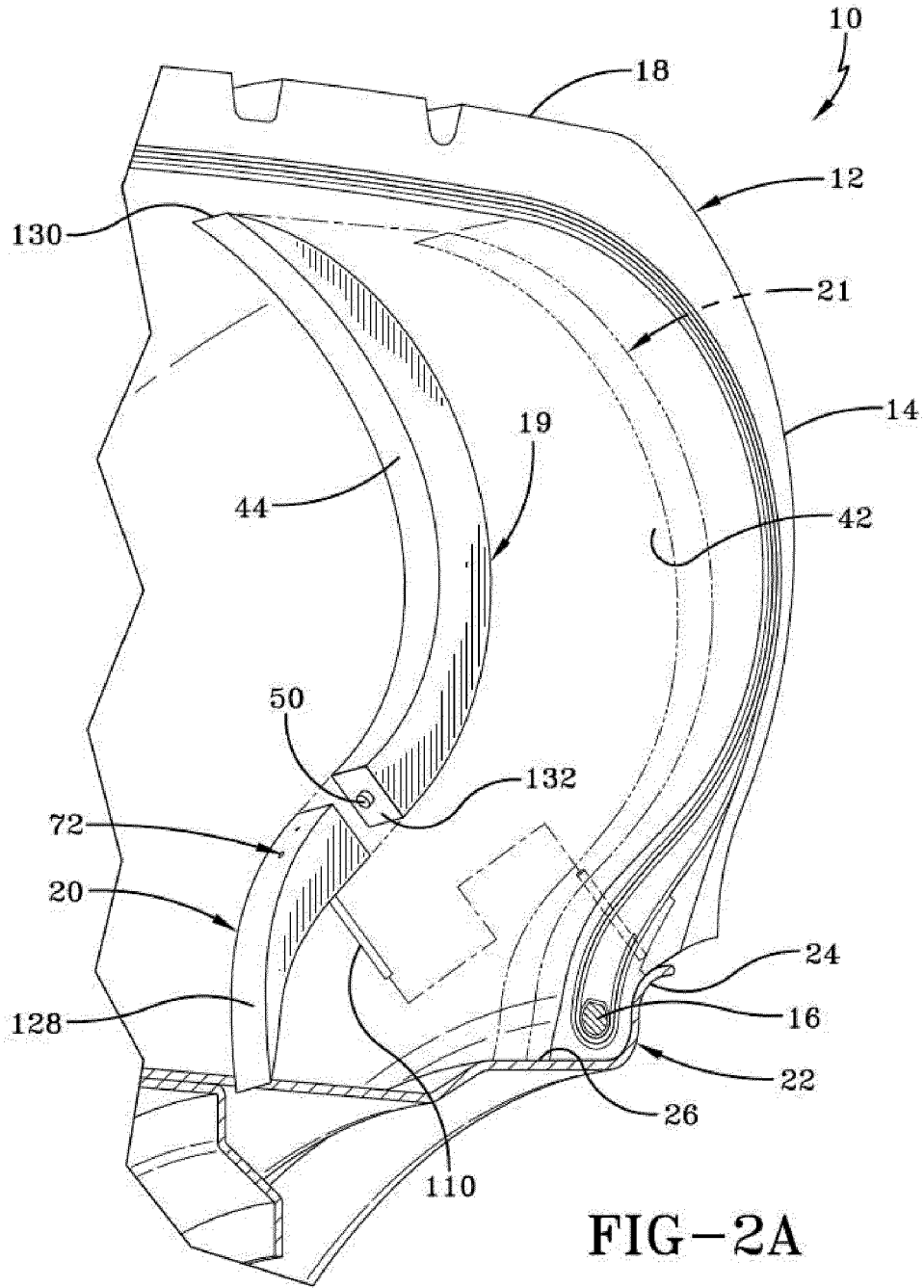
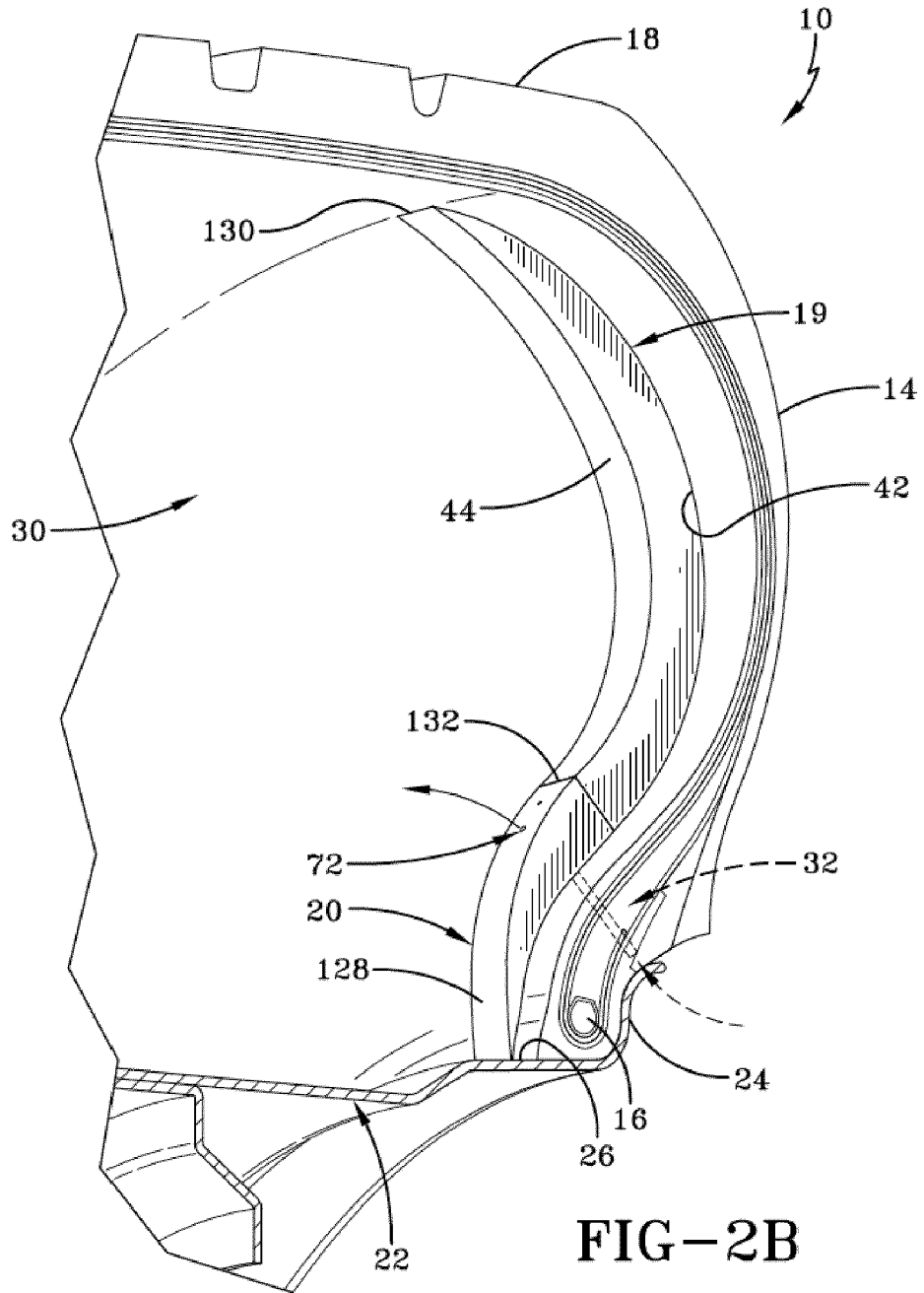

FIG-1





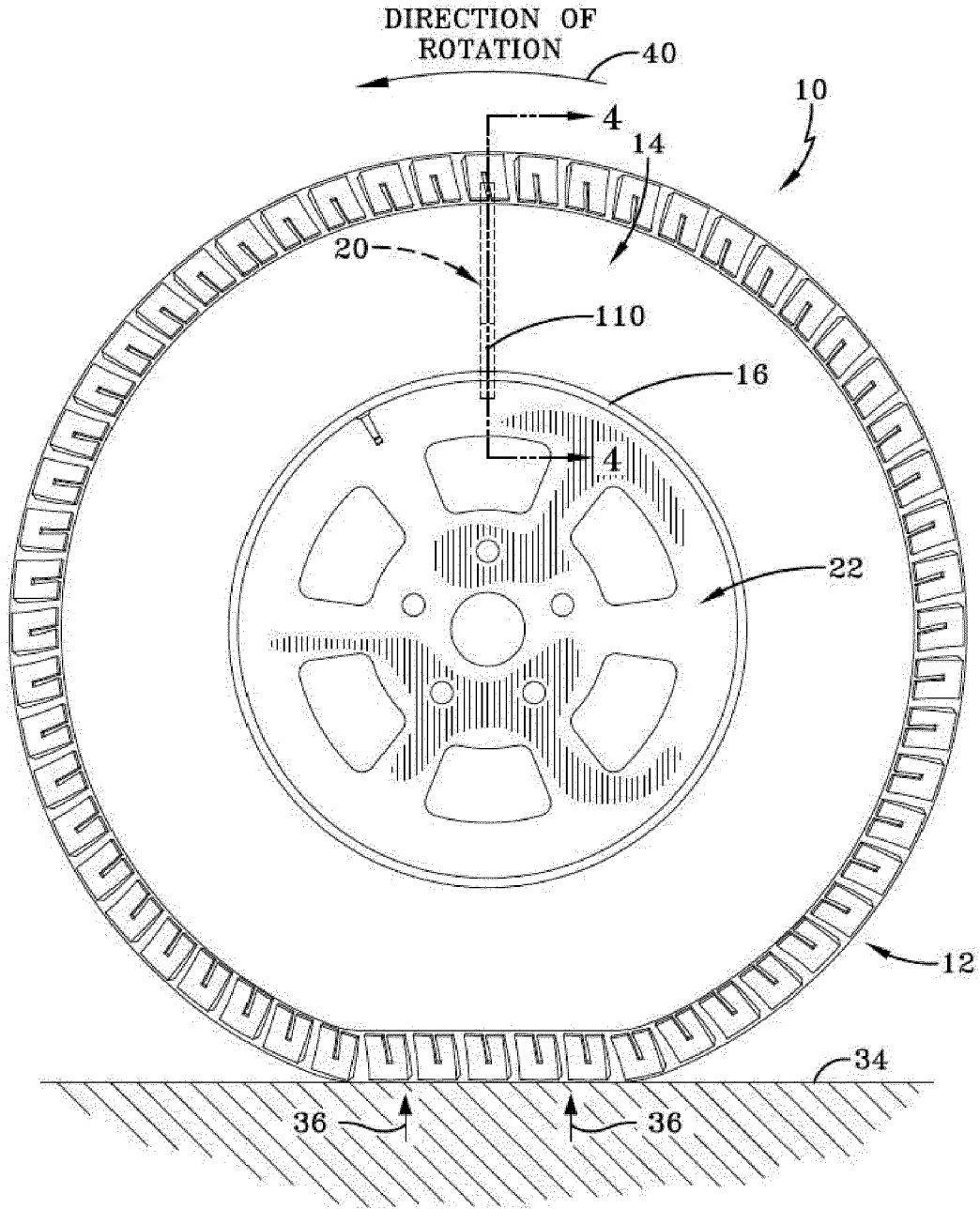

FIG-3A

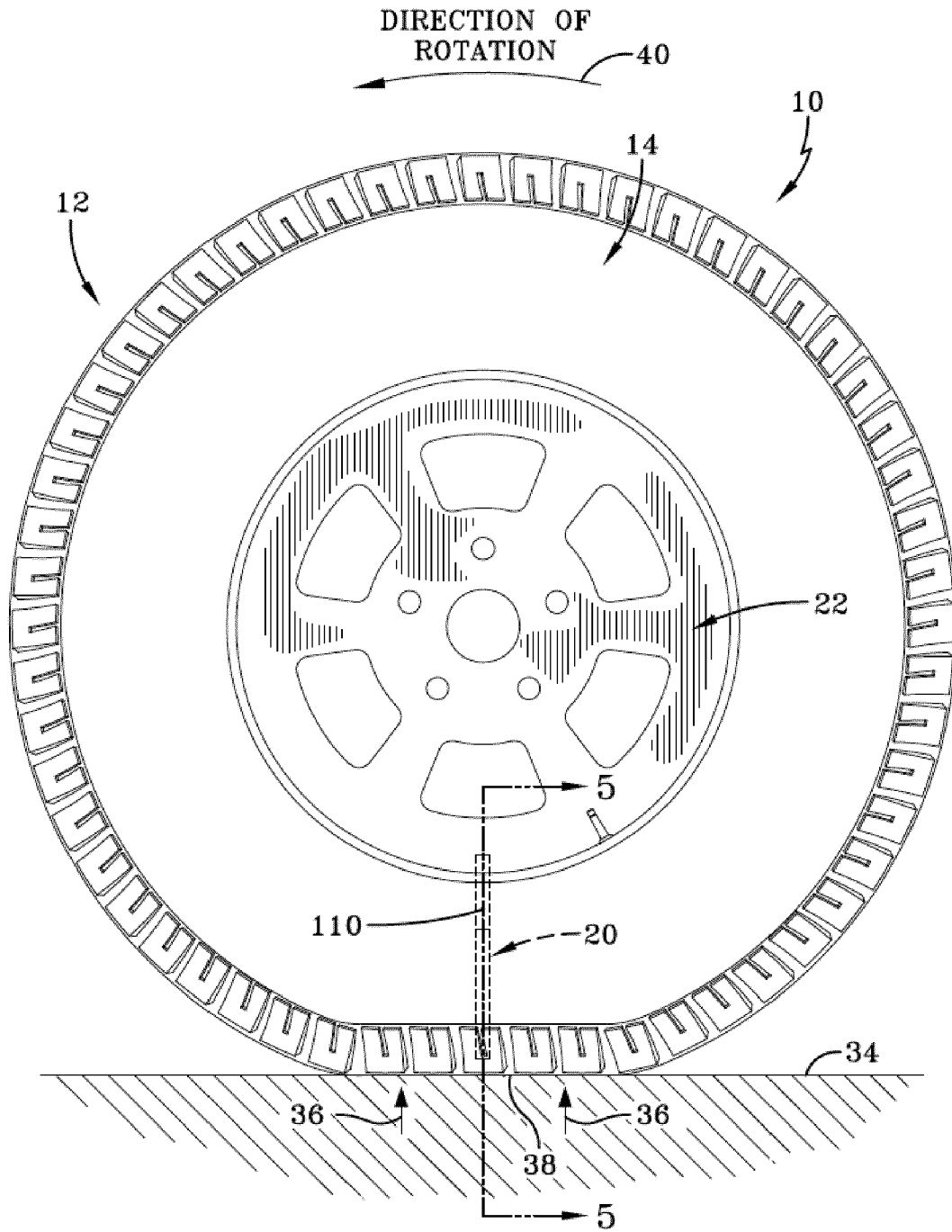

FIG-3B

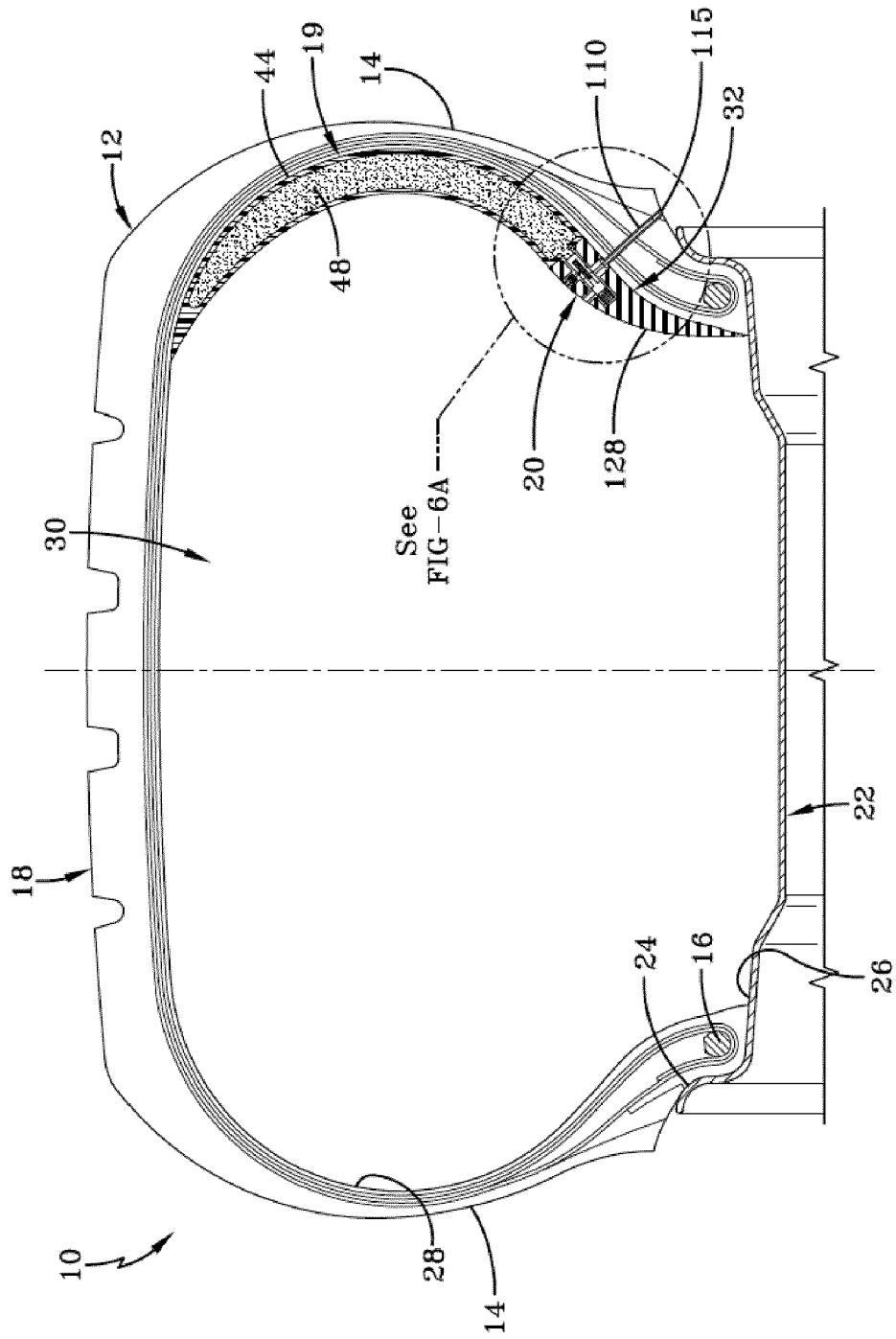

FIG-4

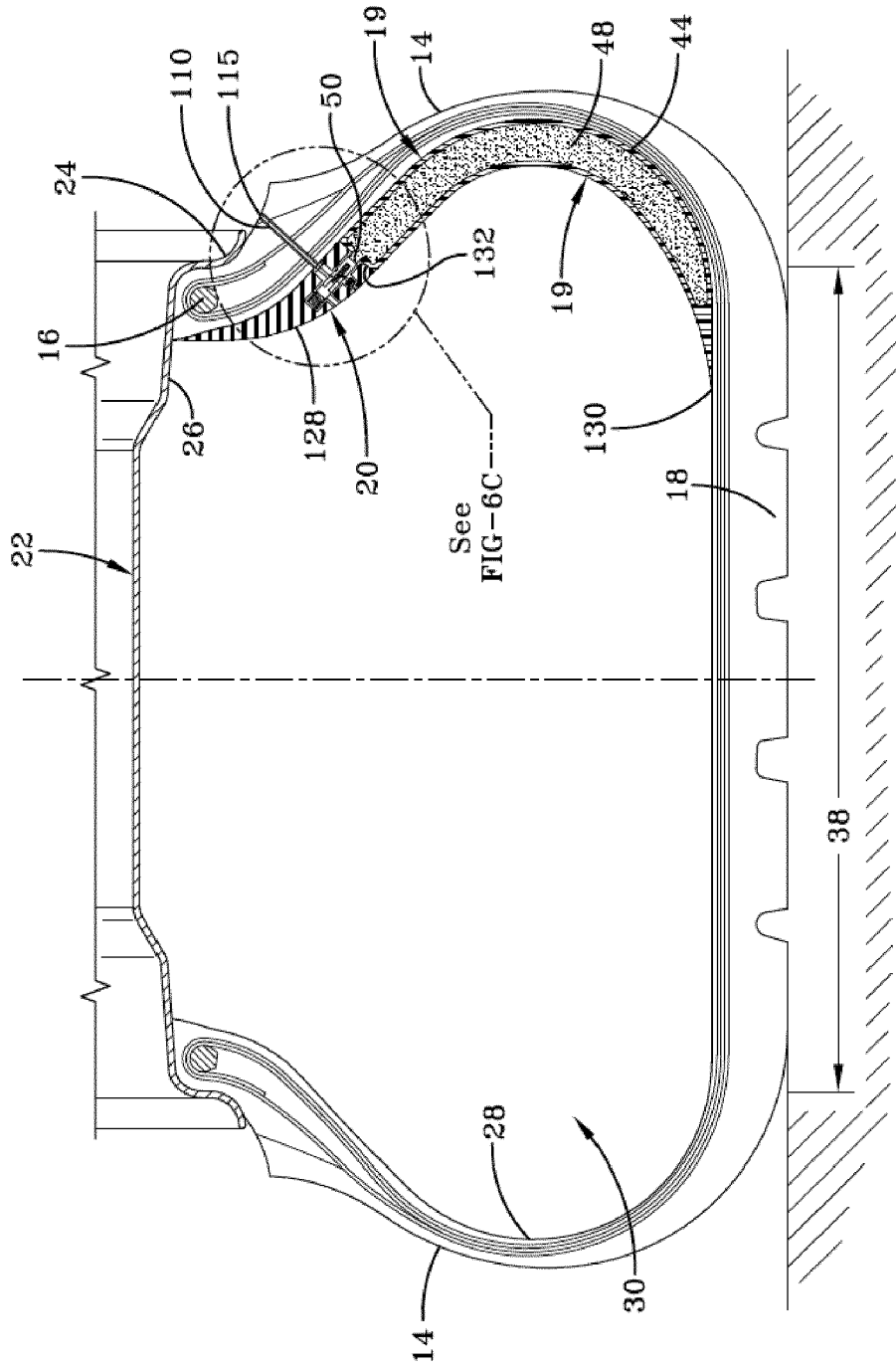

FIG-5

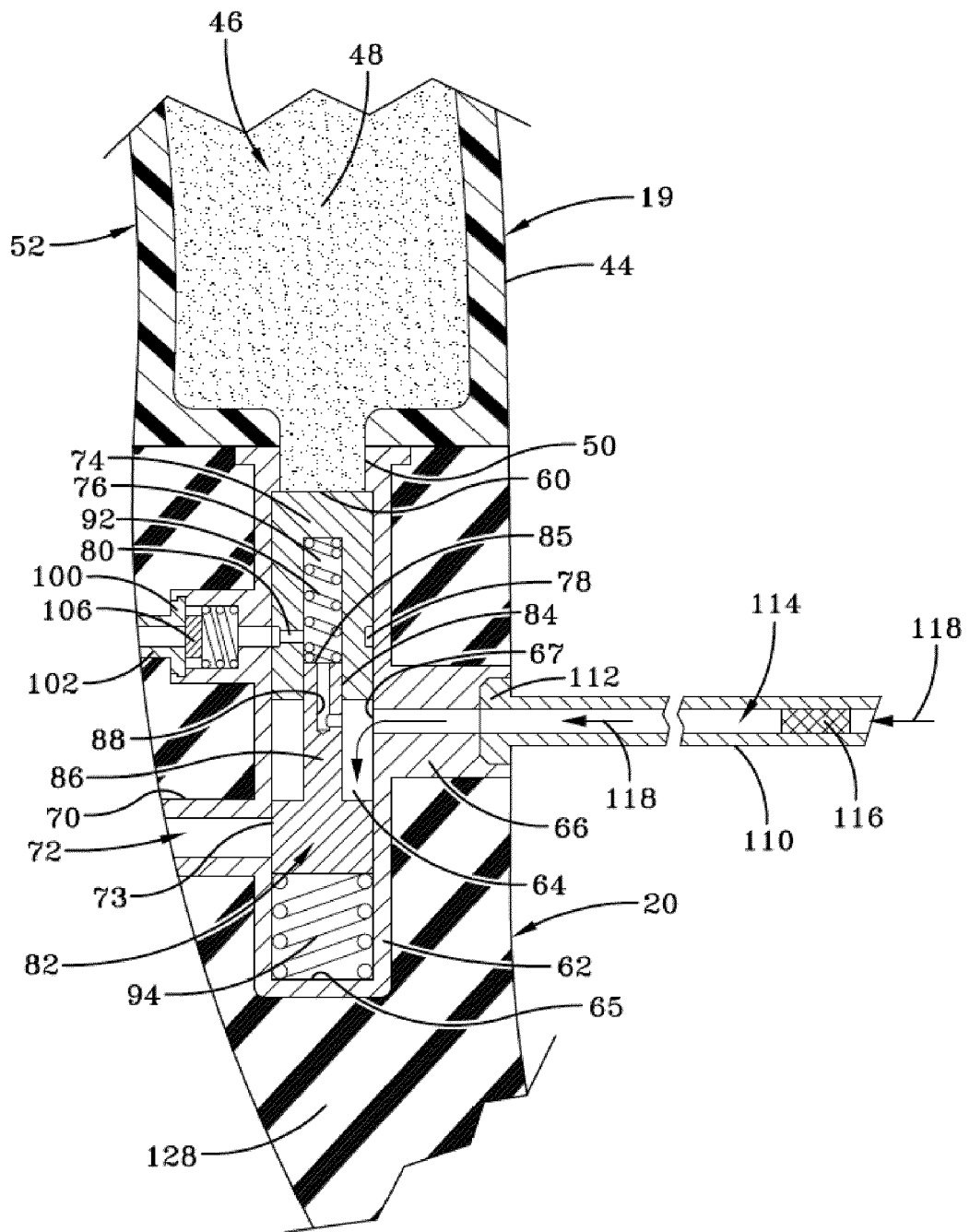

FIG-6A

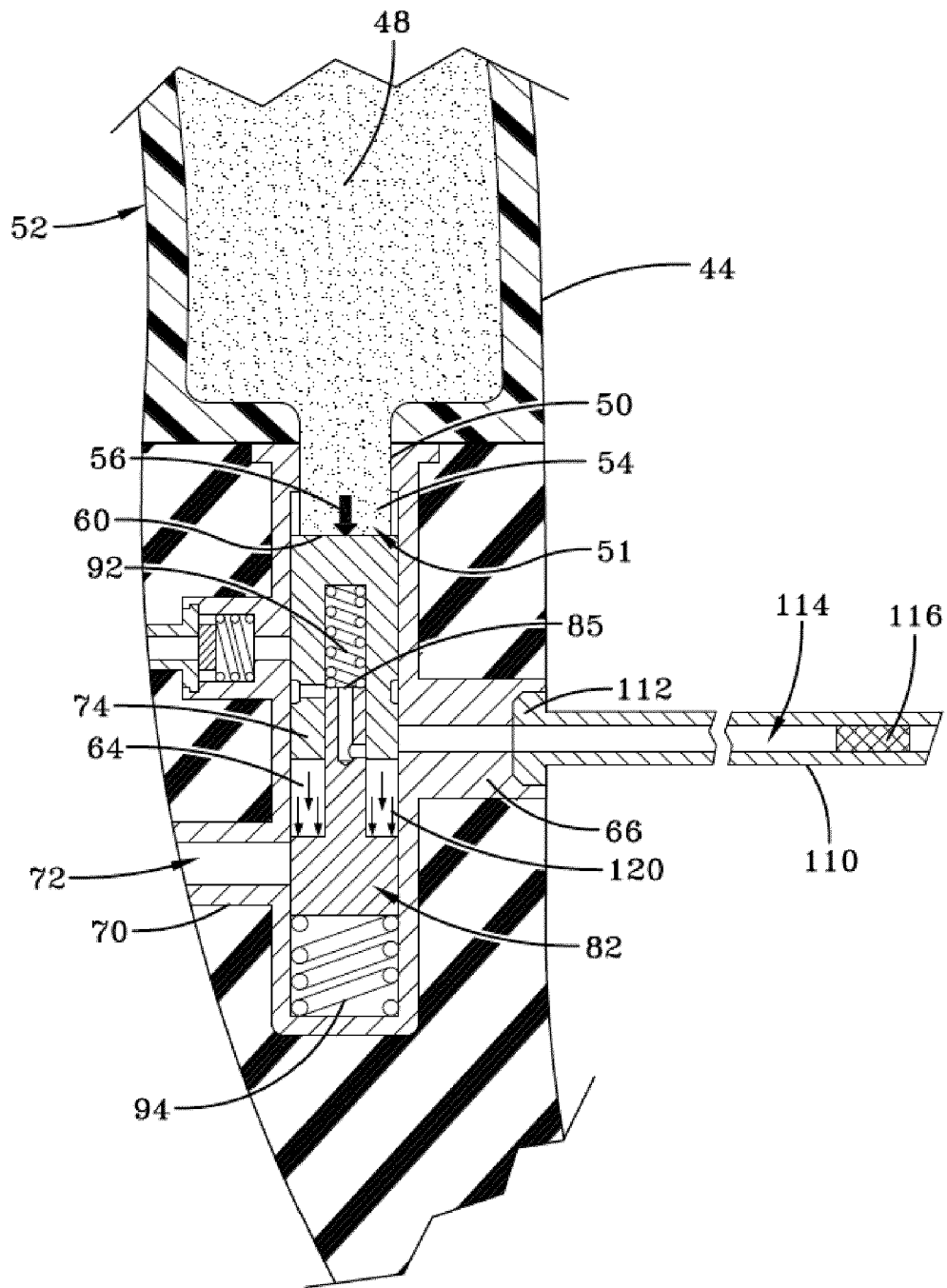

FIG-6B

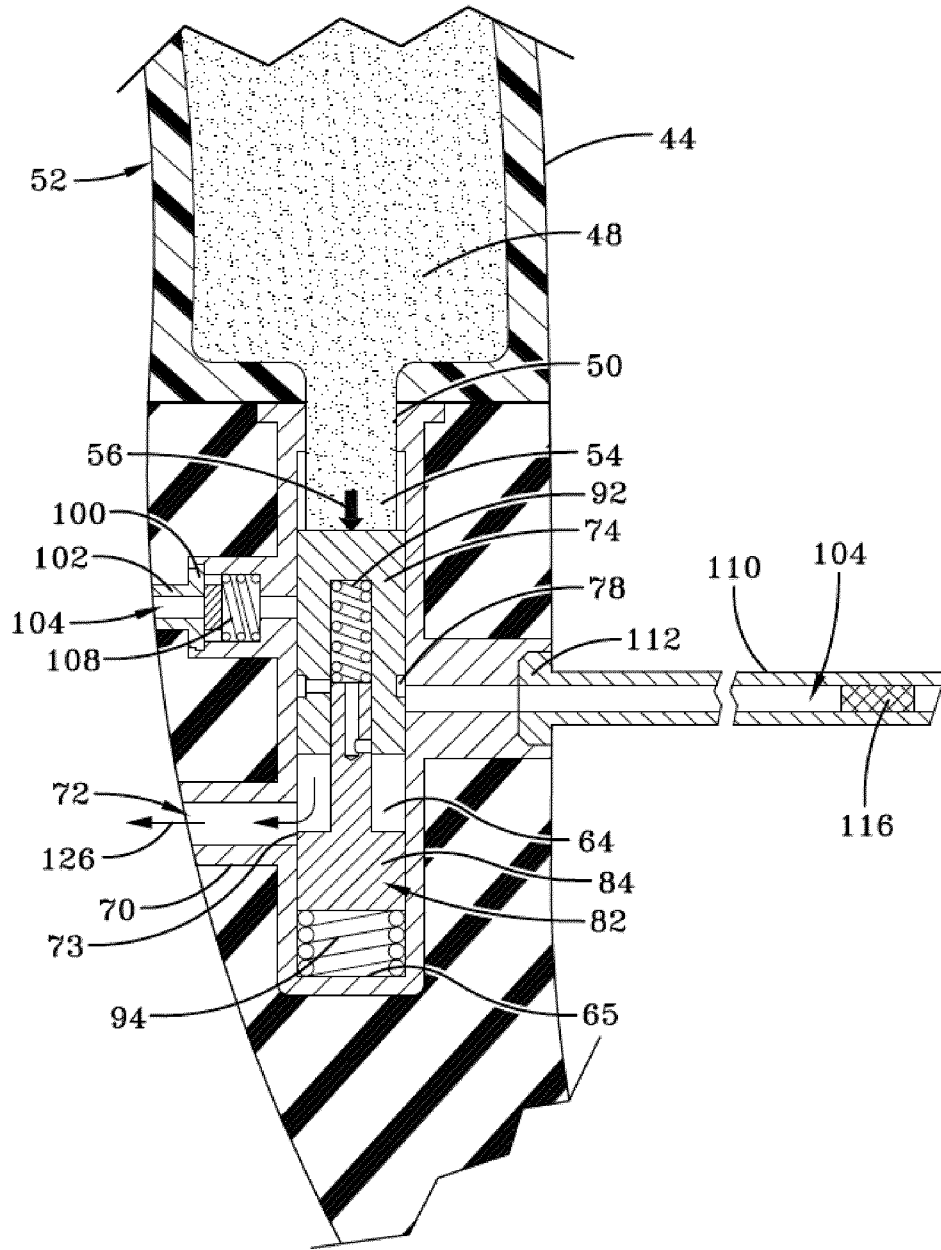

FIG-6C

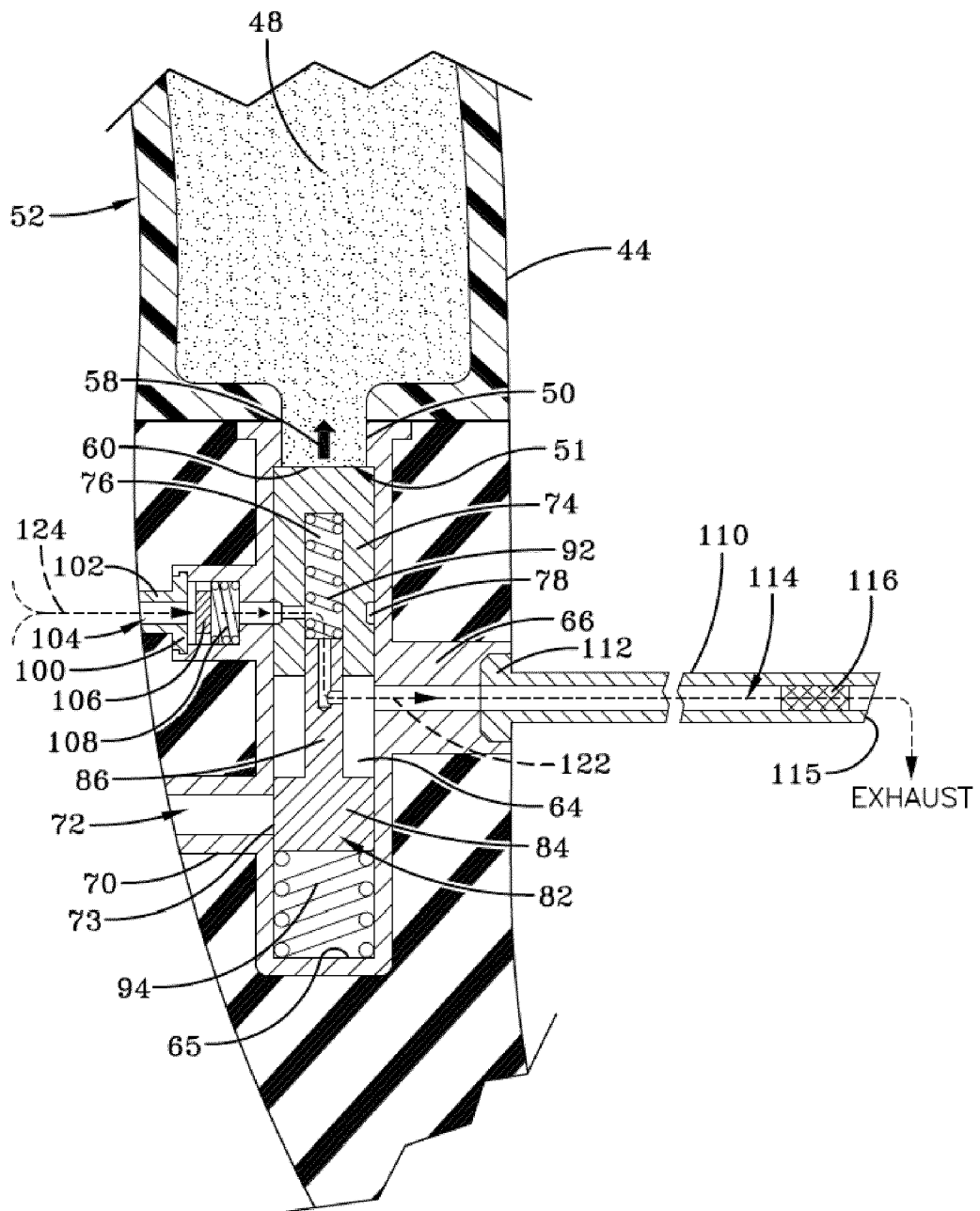

FIG-6D

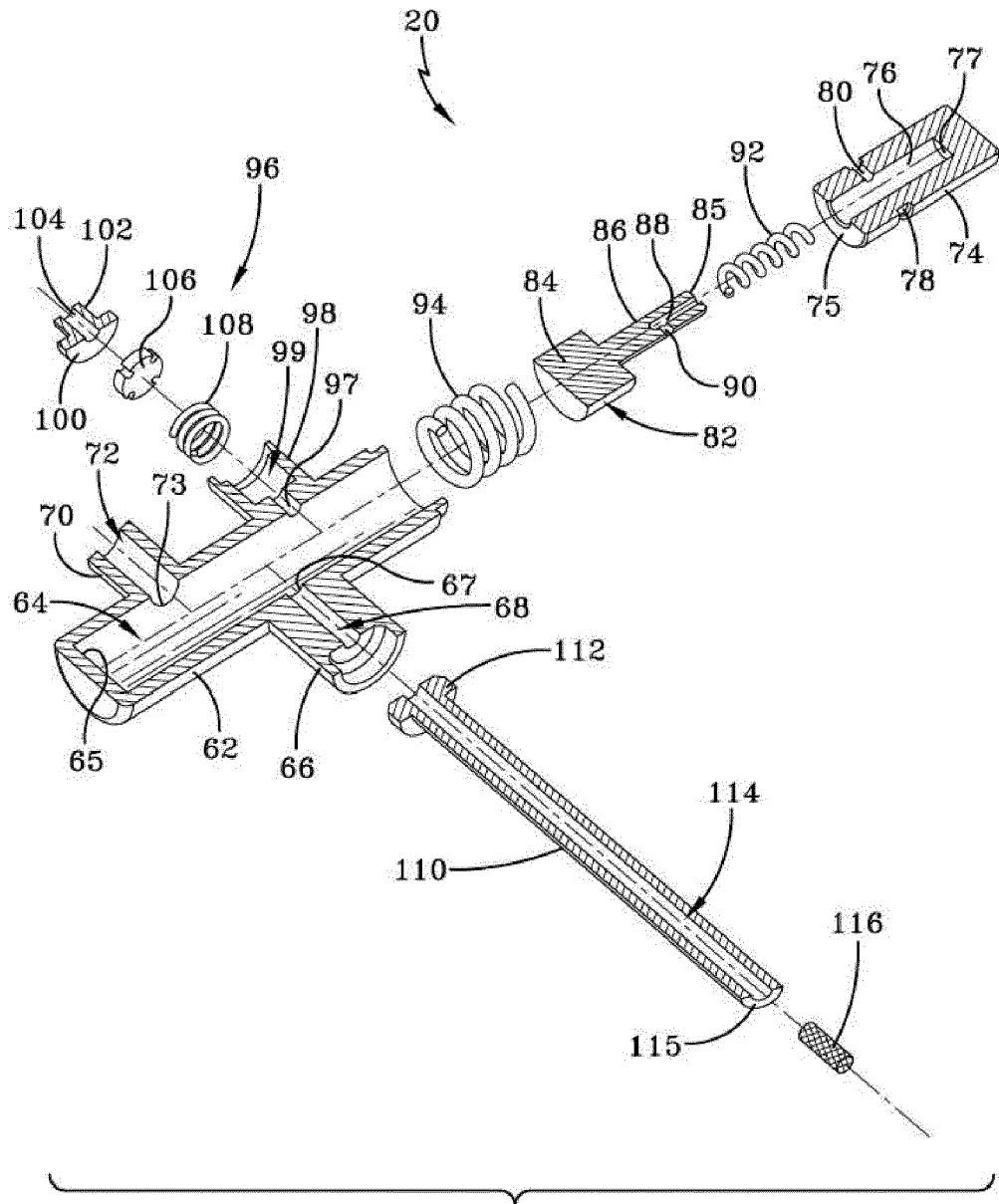

FIG-7

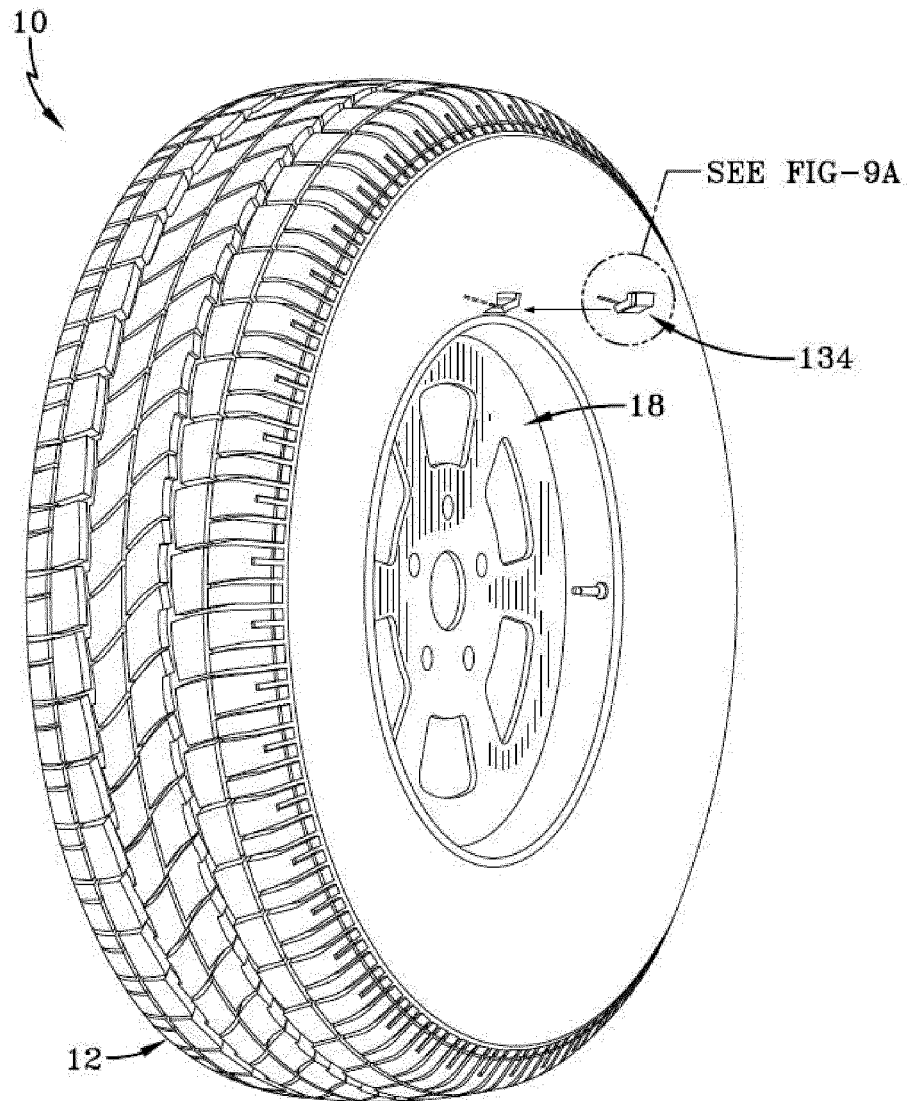
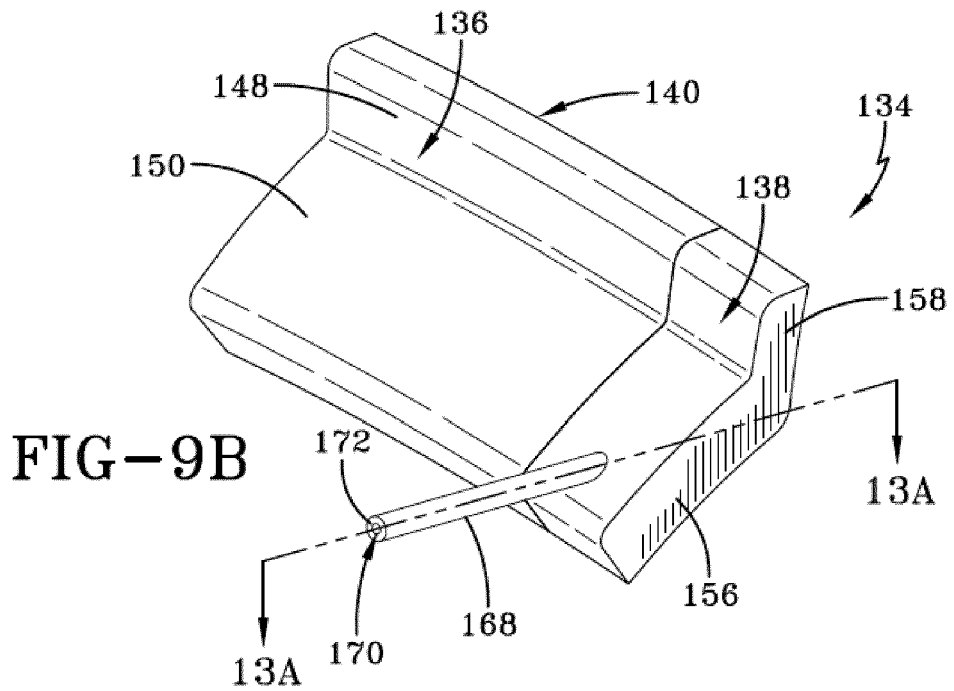
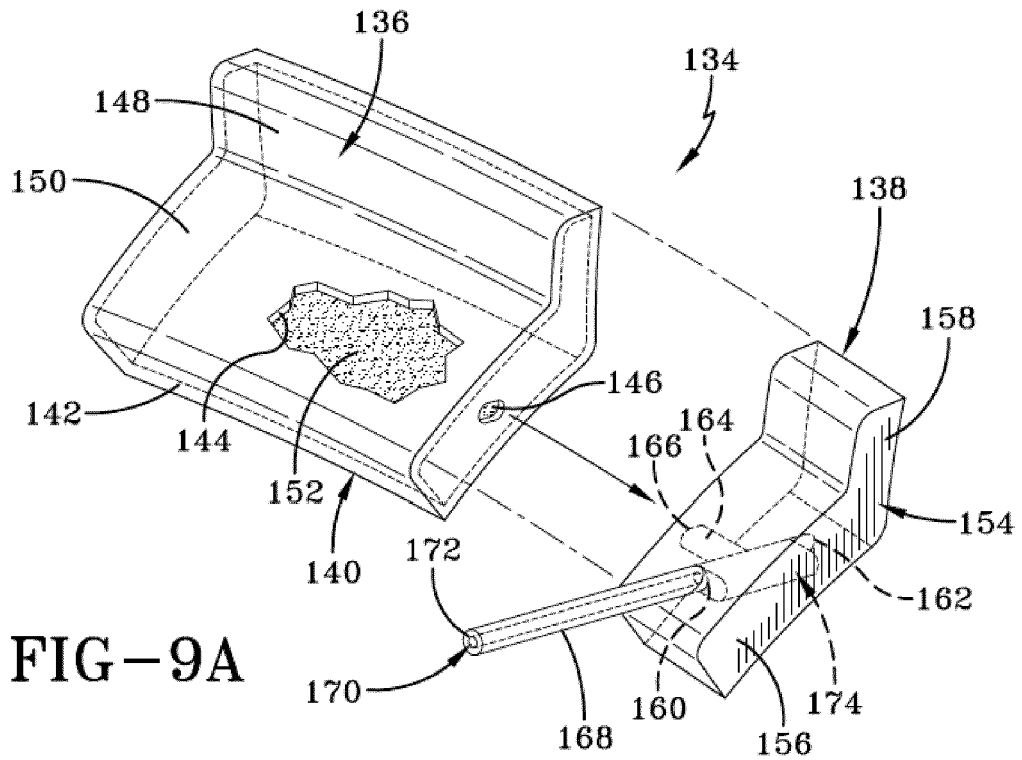

FIG-8



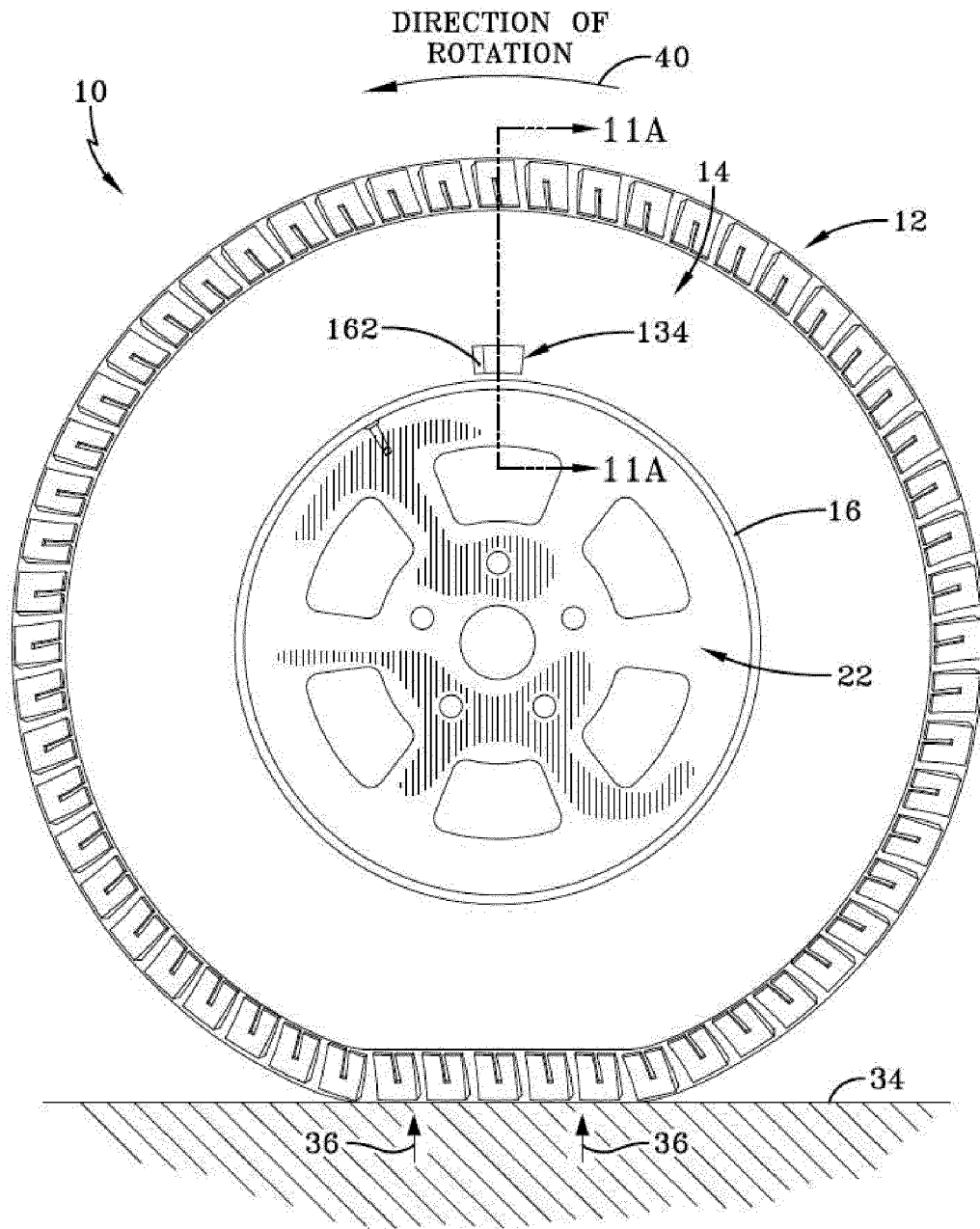

FIG-10A

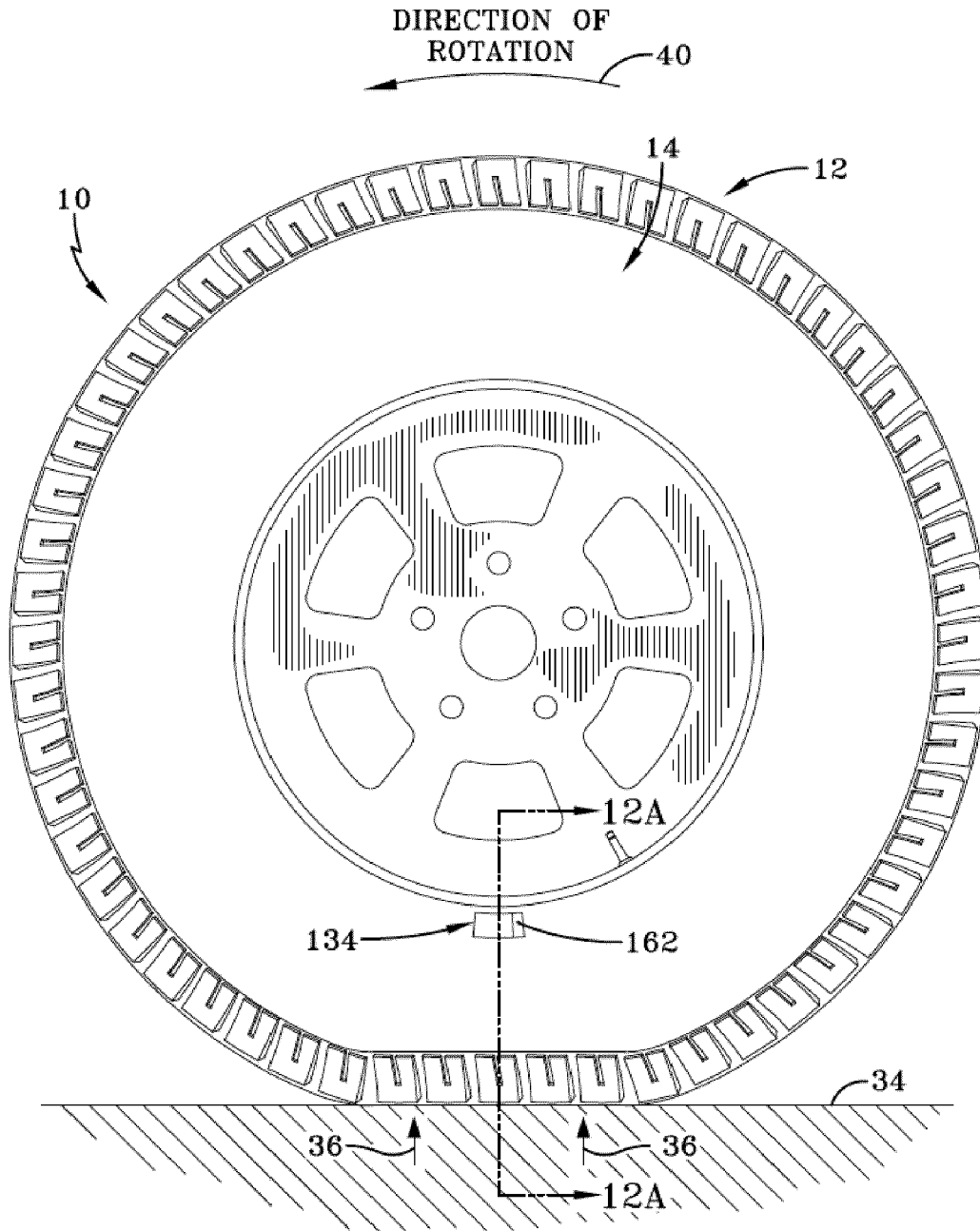

FIG-10B

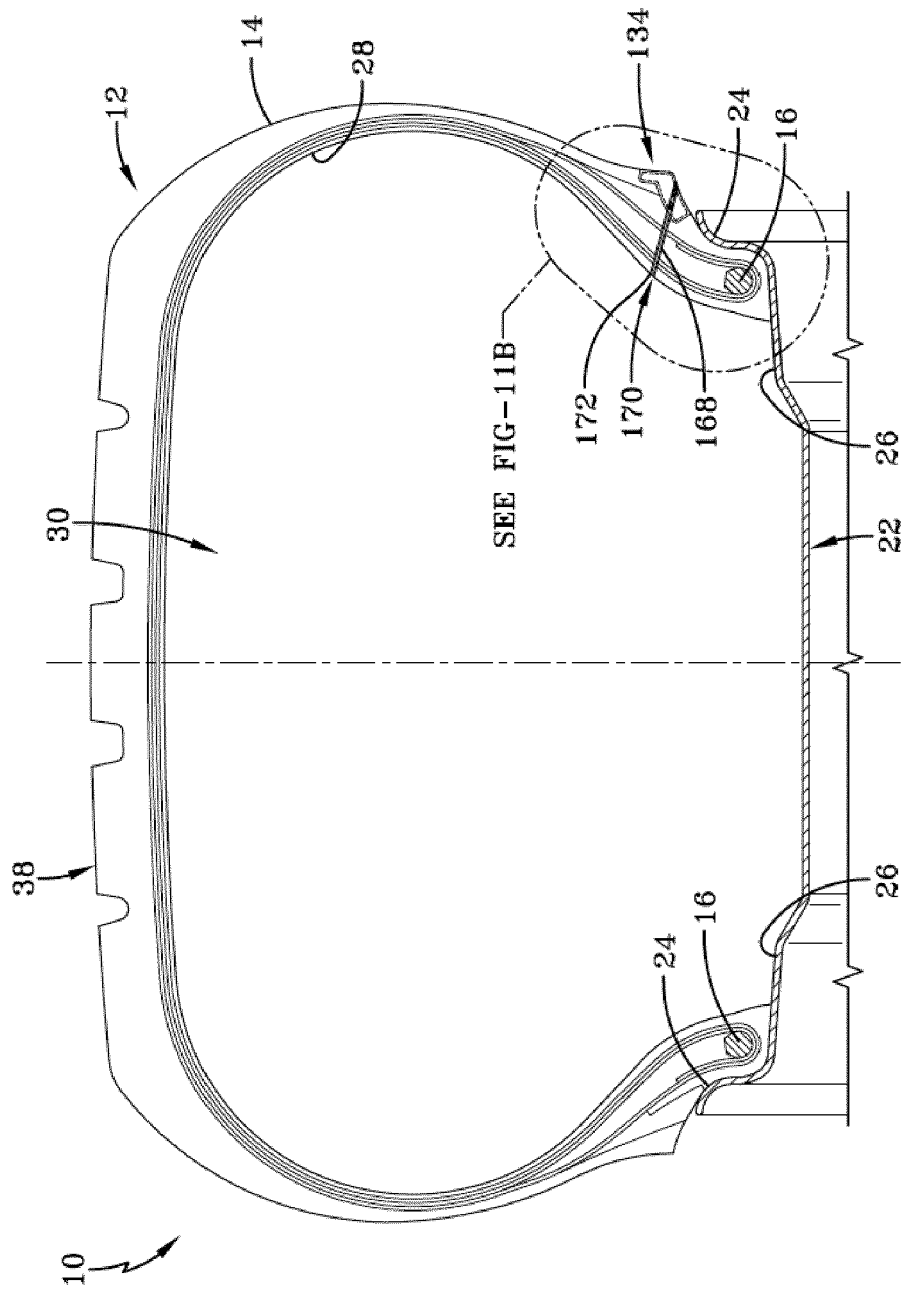

FIG-11A

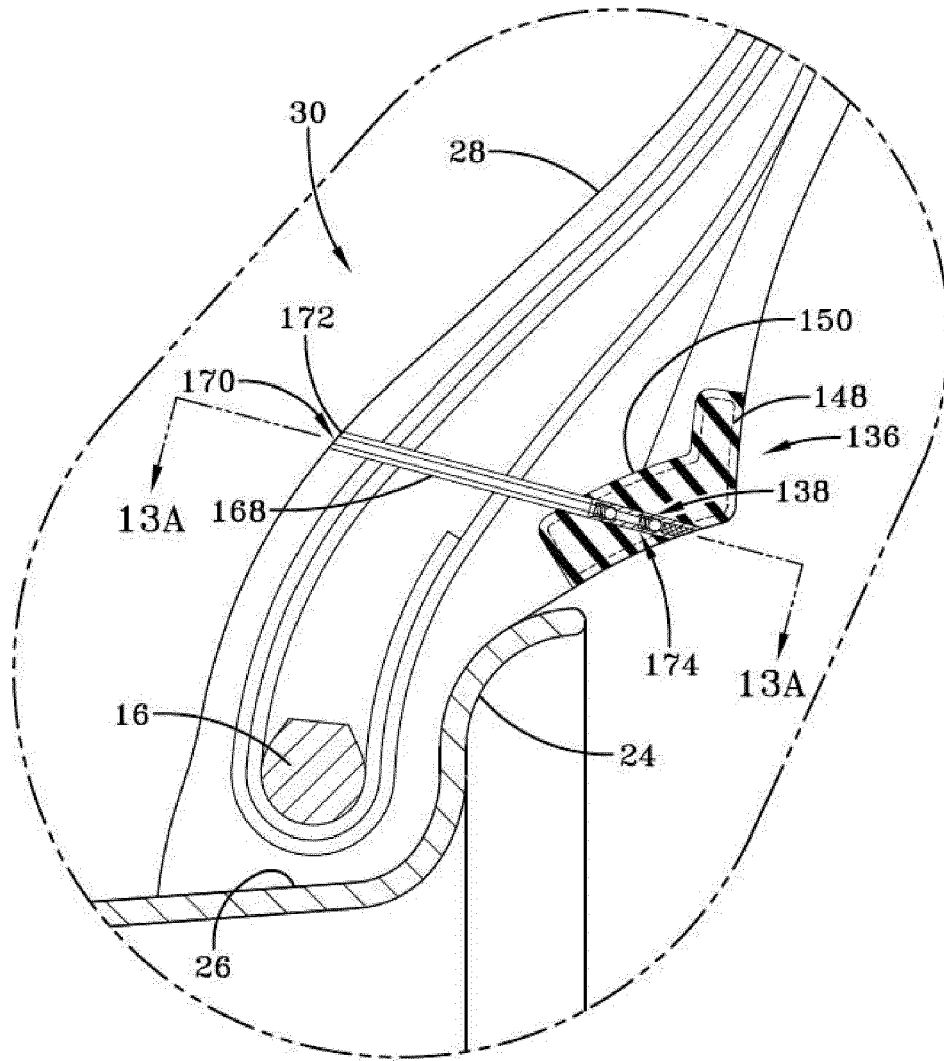

FIG-11B

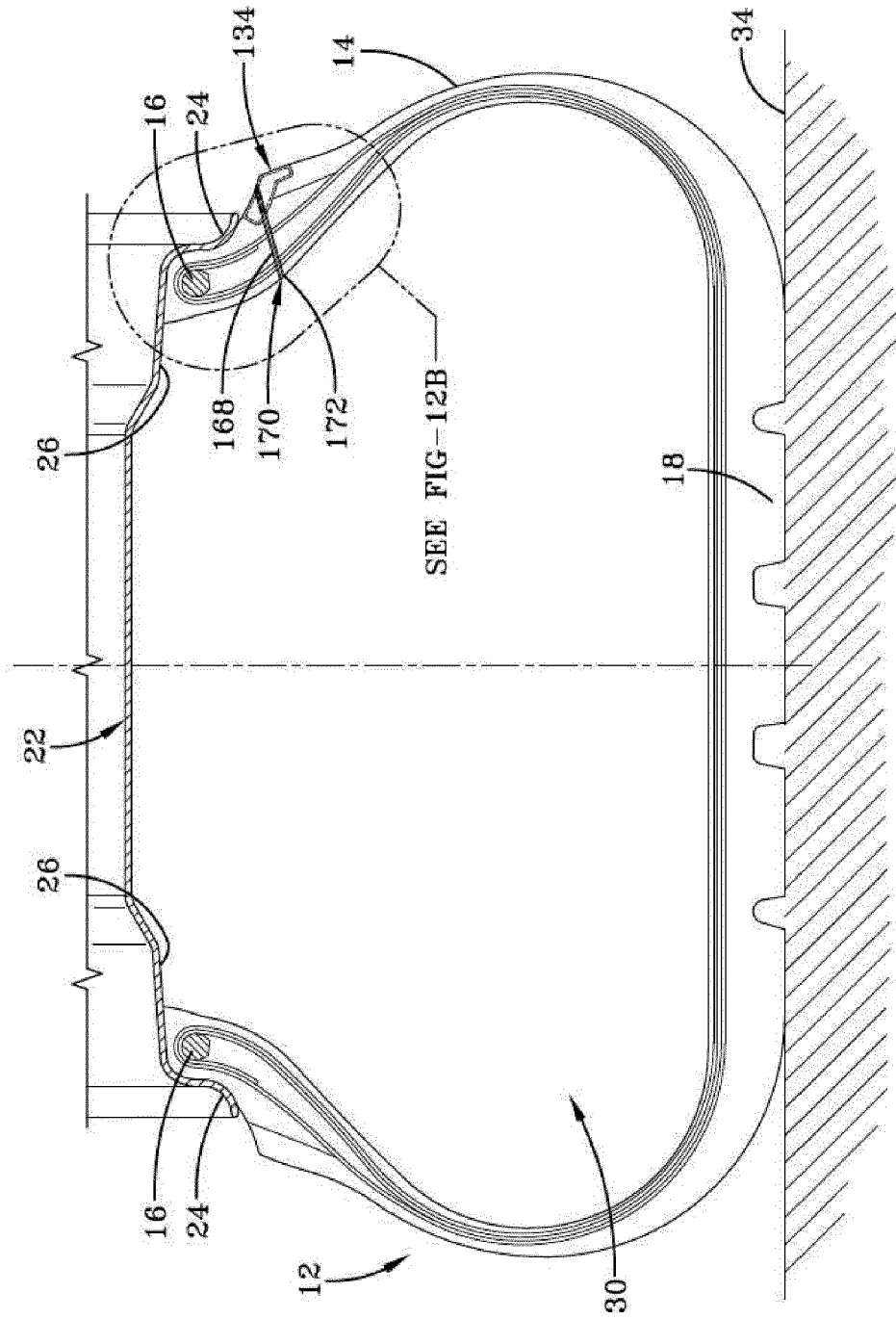

FIG-12A

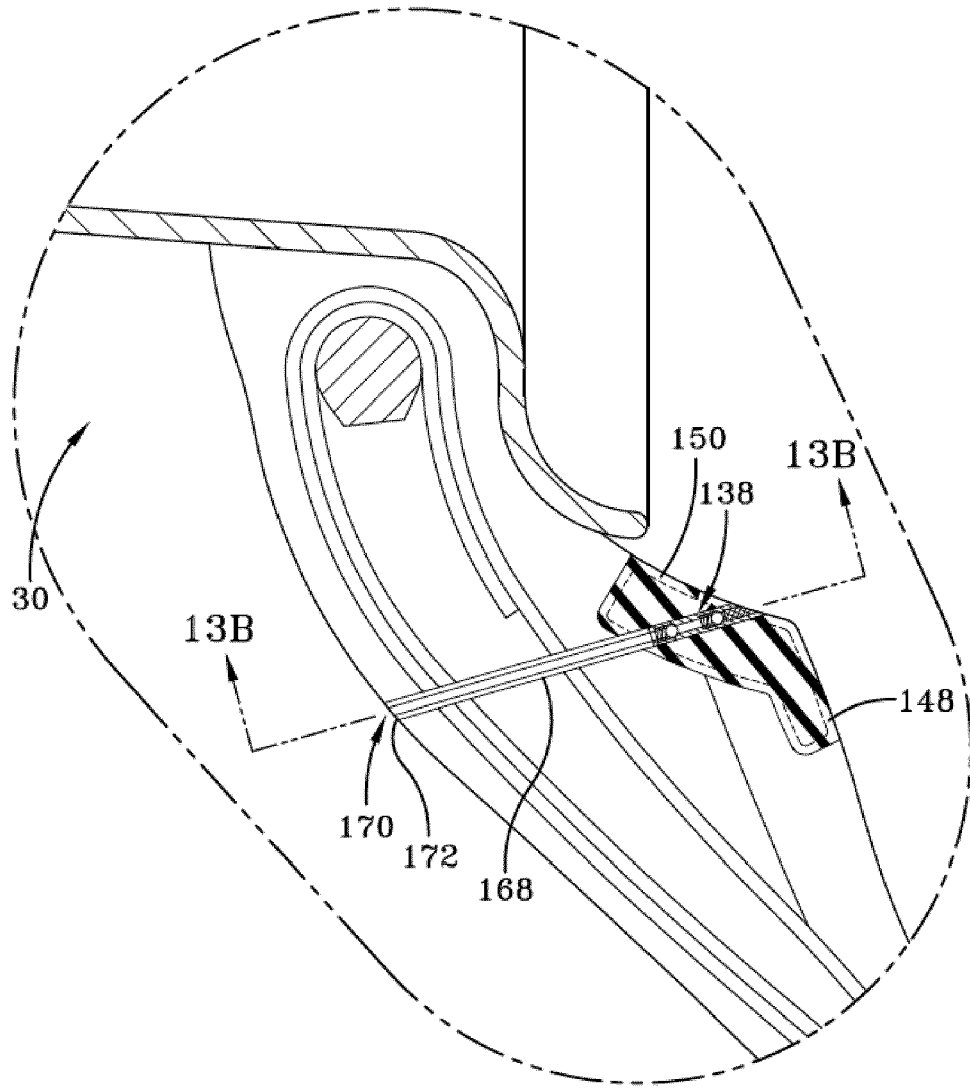

FIG-12B

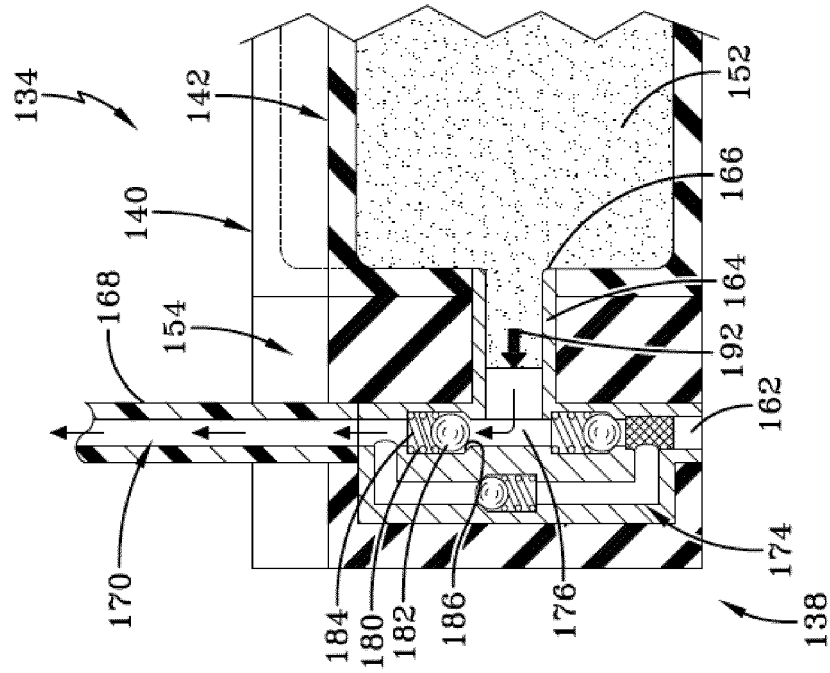

FIG-13B

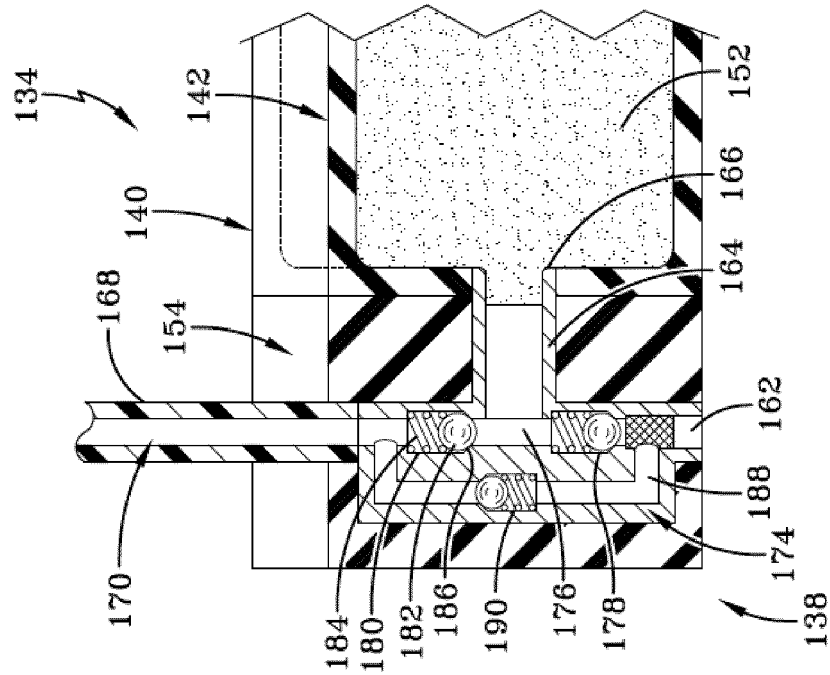

FIG-13A

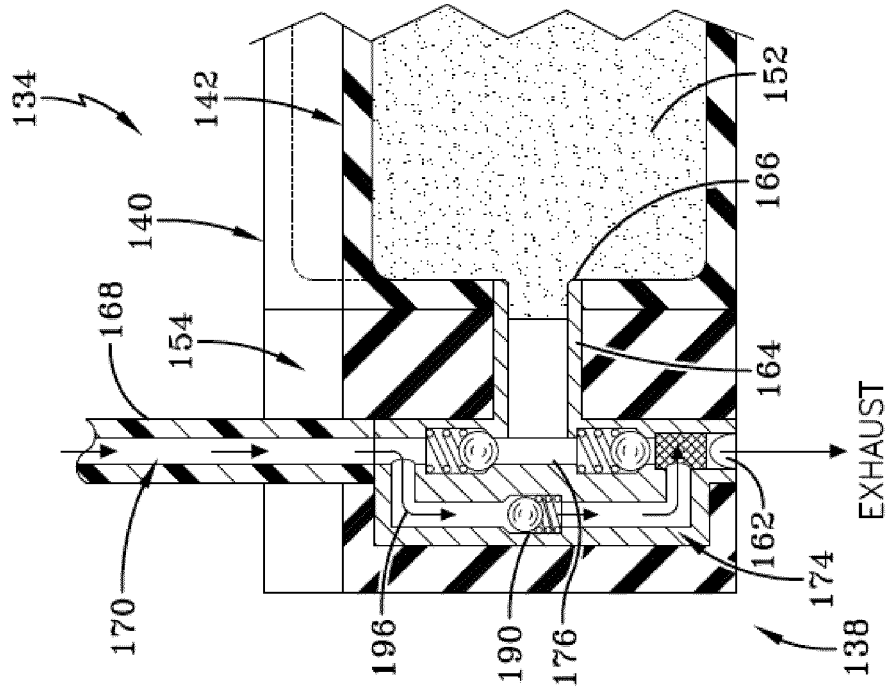

FIG-13D

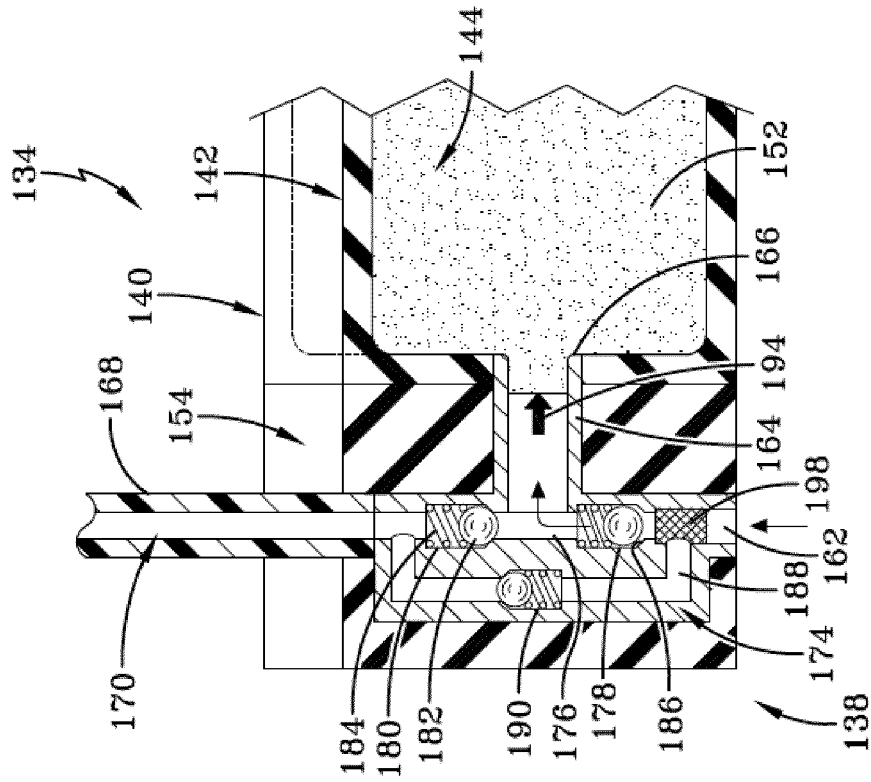
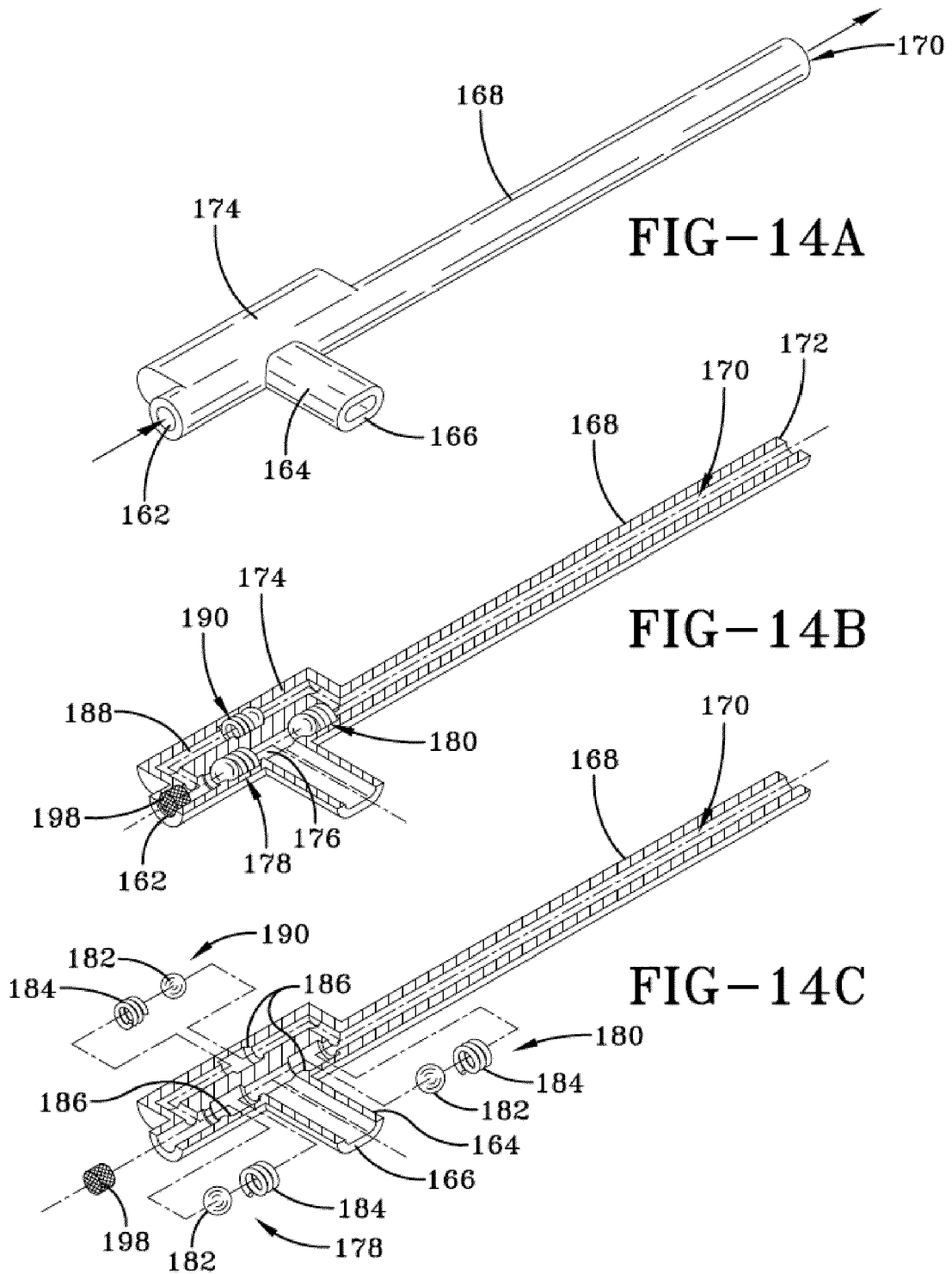

FIG-13C



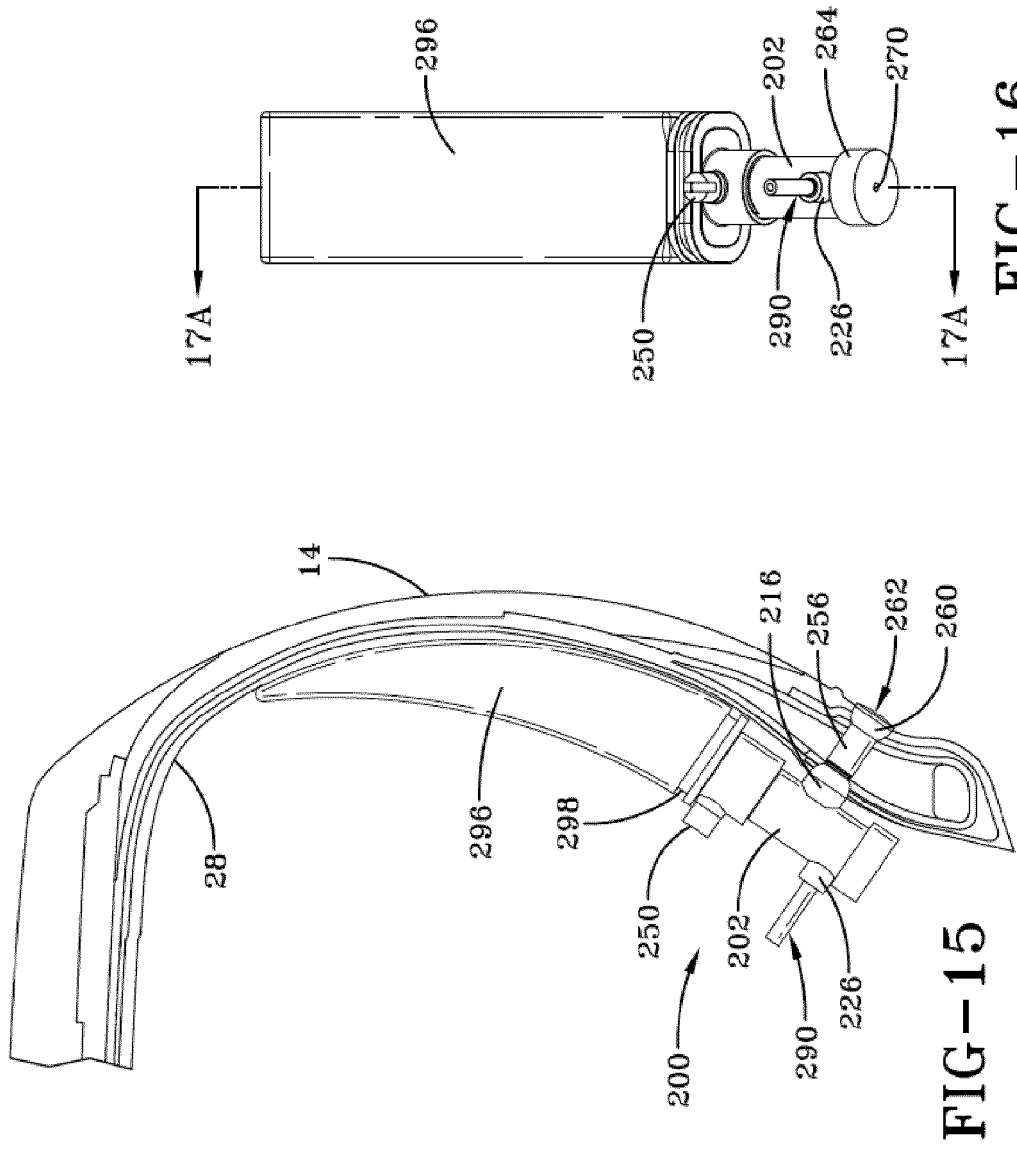
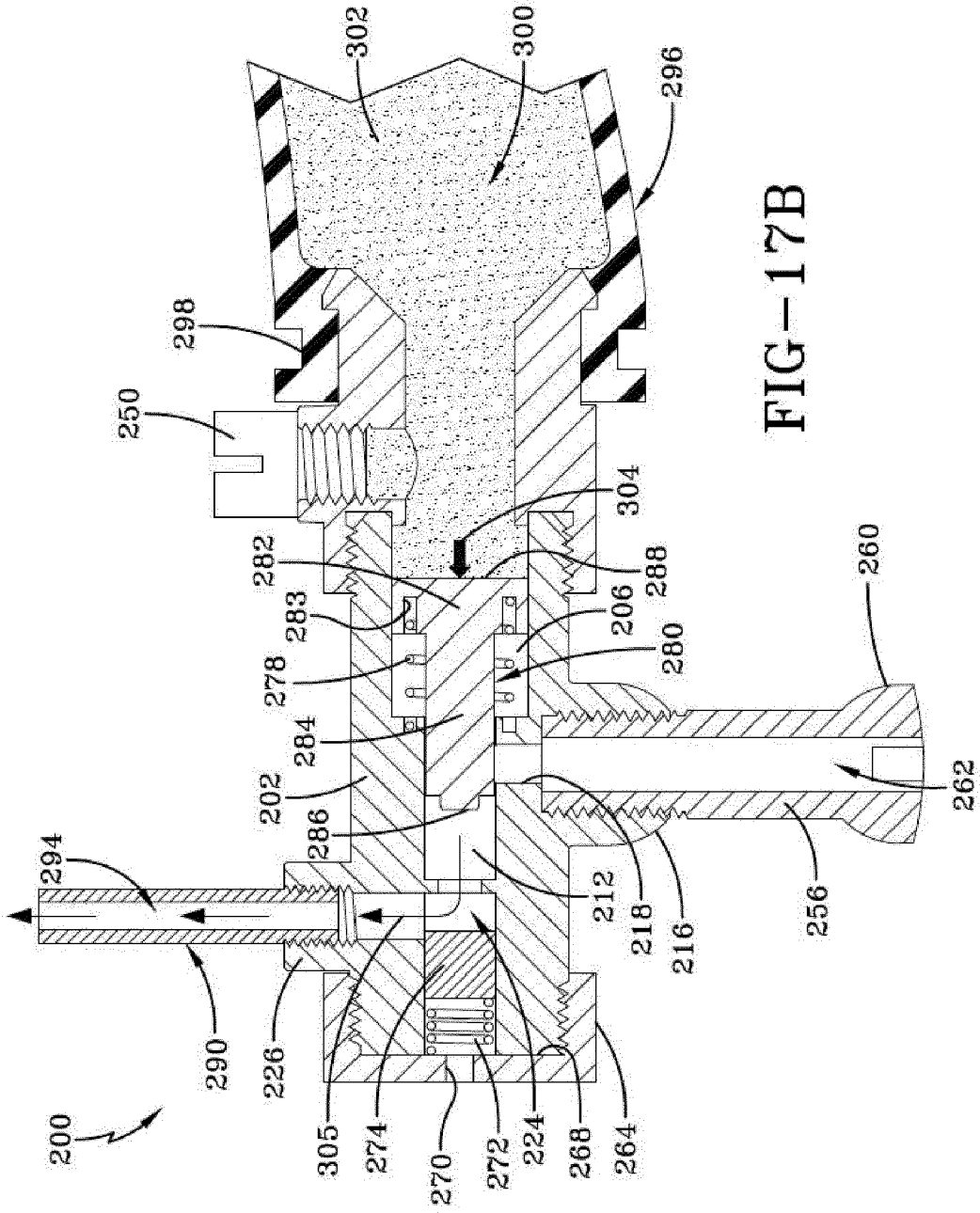
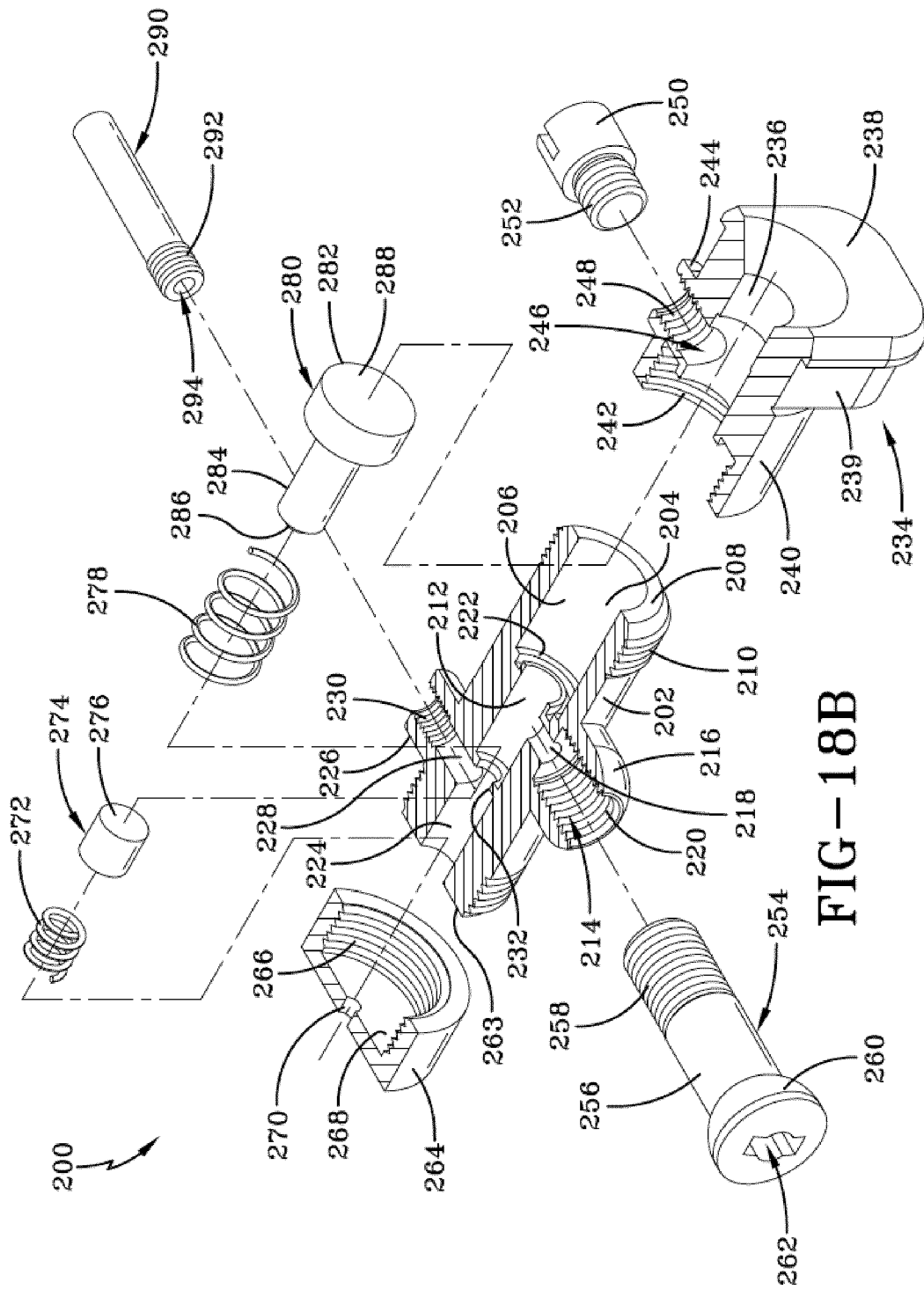

FIG-16

FIG-15





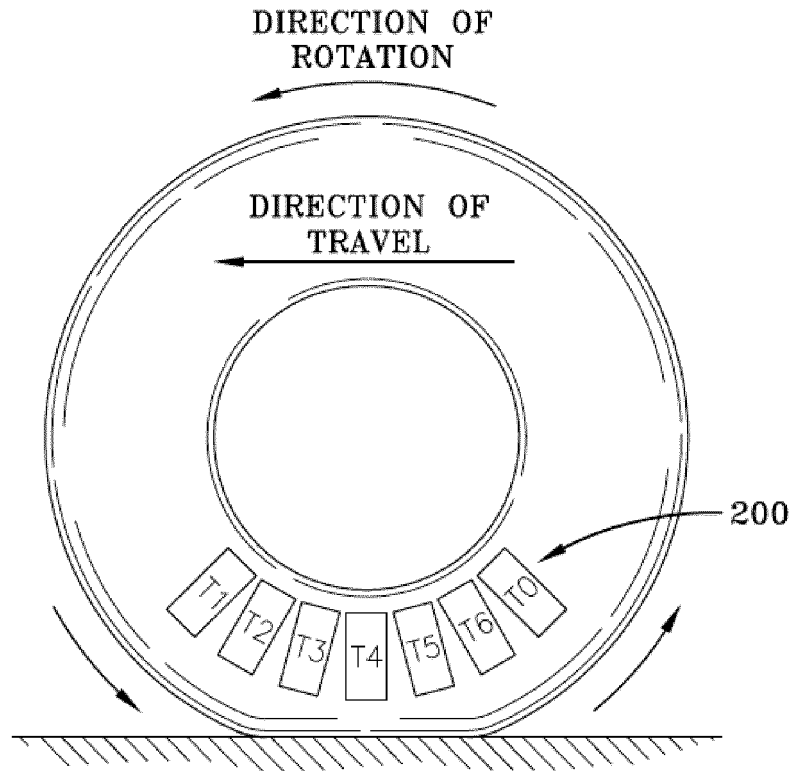

FIG-19A

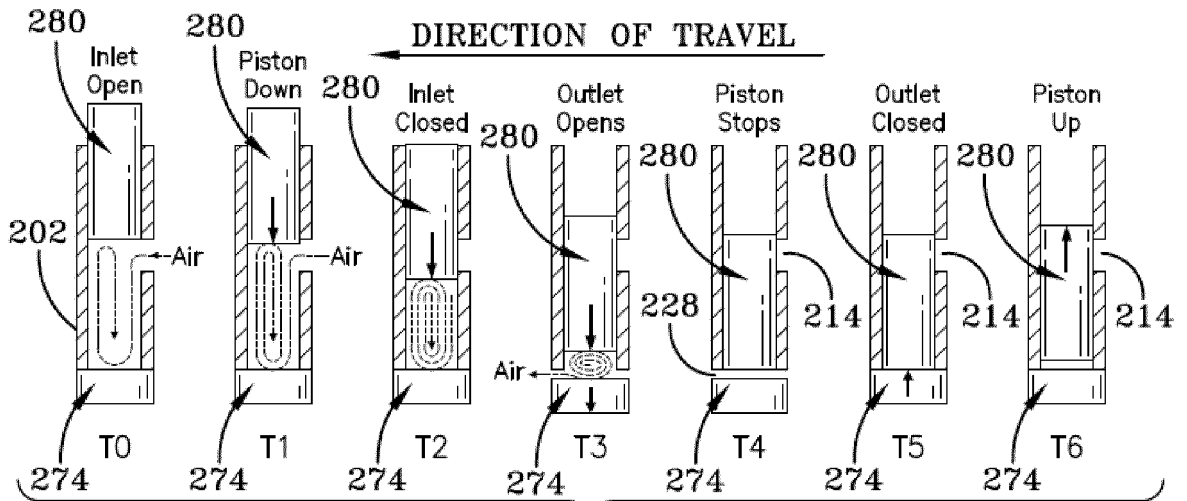

FIG-19B

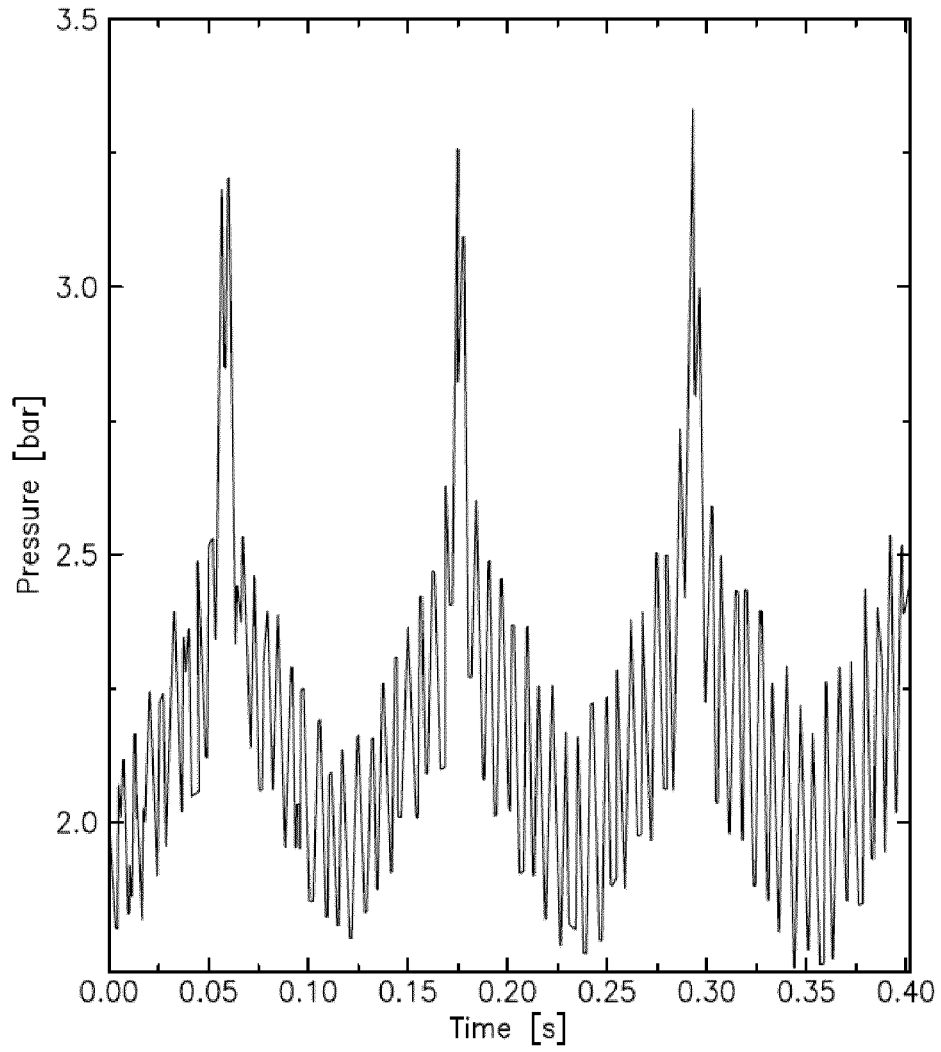

FIG-20



EUROPEAN SEARCH REPORT

Application Number
EP 12 16 0852

DOCUMENTS CONSIDERED TO BE RELEVANT			
Category	Citation of document with indication, where appropriate, of relevant passages	Relevant to claim	CLASSIFICATION OF THE APPLICATION (IPC)
X	US 4 651 792 A (TAYLOR ROBERT D [US]) 24 March 1987 (1987-03-24)	1,2	INV. B60C23/12
Y	* column 2, line 60 - column 5, line 18; figures 1-4 *	10-12	

A	US 5 975 174 A (LOEWE RICHARD T [US]) 2 November 1999 (1999-11-02)	1-14	
	* column 4, line 1 - column 6, line 65; figures 1-9 *		

A	US 2008/289739 A1 (BOL STEPHEN J [US]) 27 November 2008 (2008-11-27)	1,13	
	* abstract; figures 1,1a,2,19 *		

Y	US 4 169 497 A (TSURUTA YASUO [JP]) 2 October 1979 (1979-10-02)	10-12	
	* column 2, line 30 - column 4, line 37; figures 1a-2b *		

			TECHNICAL FIELDS SEARCHED (IPC)
			B60C
The present search report has been drawn up for all claims			
Place of search Munich		Date of completion of the search 31 July 2012	Examiner Brito, Fernando
CATEGORY OF CITED DOCUMENTS		T : theory or principle underlying the invention E : earlier patent document, but published on, or after the filing date D : document cited in the application L : document cited for other reasons & : member of the same patent family, corresponding document	
X : particularly relevant if taken alone Y : particularly relevant if combined with another document of the same category A : technological background O : non-written disclosure P : intermediate document			

1 EPO FORM 1503 03.82 (P04C01)

**ANNEX TO THE EUROPEAN SEARCH REPORT
ON EUROPEAN PATENT APPLICATION NO.**

EP 12 16 0852

This annex lists the patent family members relating to the patent documents cited in the above-mentioned European search report. The members are as contained in the European Patent Office EDP file on
The European Patent Office is in no way liable for these particulars which are merely given for the purpose of information.

31-07-2012

Patent document cited in search report		Publication date	Patent family member(s)	Publication date
US 4651792	A	24-03-1987	NONE	

US 5975174	A	02-11-1999	NONE	

US 2008289739	A1	27-11-2008	DE 112008001428 T5	29-04-2010
			US 2008289739 A1	27-11-2008
			WO 2008144694 A1	27-11-2008

US 4169497	A	02-10-1979	NONE	

EPO FORM P0459

For more details about this annex : see Official Journal of the European Patent Office, No. 12/82